

Issue Date: 10-27-2008
Revision Date: 07-03-2025
Renewal Date: 07-31-2026

DIVISION: 08 00 00 – OPENINGS
Section: 08 62 00 – Unit Skylights

REPORT HOLDER:
Solatube International, Inc.
2210 Oak Ridge Way
Vista, CA 92081
(760)-597-4400
www.solatube.com
info@solatube.com

REPORT SUBJECT:
Solatube Tubular Daylighting Devices

1.0 SCOPE OF EVALUATION

1.1 This Research Report addresses compliance with the following Codes:

- 2024, 2021, 2018 *International Building Code*® (IBC)
- 2024, 2021, 2018 *International Residential Code*® (IRC)
- 2023, 2020 *Florida Building Code* (see Section 9), *Including High Velocity Hurricane Zones for 160 DS, 290 DS, 750 DS and M74 DS models.*

NOTE: This report references 2024 Code sections with [2021, 2018, FBC] Code sections shown in brackets where they differ.

1.2 *Solatube Tubular Daylighting Devices* have been evaluated for the following properties:

- Structural Performance
- Durability (UV, Weathering)
- Burning

1.3 *Solatube Tubular Daylighting Devices* have been evaluated for the following uses:

- Solatube Tubular Daylighting Devices recognized in this report are plastic glazed unit skylights complying with IBC Sections 2405 and 2610 and IRC Section R324.6 [R308.6].

2.0 STATEMENT OF COMPLIANCE

Solatube Tubular Daylighting Devices comply with the Codes listed in Section 1.1, for the properties stated in Section 1.2 and uses stated in Section 1.3, when installed as described in this report, including the Conditions of Use stated in Section 6.

3.0 DESCRIPTION

3.1 *Solatube Tubular Daylighting Device* (TDD) Models recognized by this report are:

The *Solatube Brighten Up*® Series Models 160 DS (10-inch Tube Dia.), 290 DS (14-inch Tube Dia.) daylighting systems.

The *Solatube SolaMaster*® Series Models 300 DS-C in a 14-inch tube diameter, and 330 DS-O, 330 DS-C, 750 DS-O and 750 DS-C are daylighting systems available in a 21-inch tube diameter. The “O” and “C” designation refers to Open (O) and Closed (C) ceiling configurations.

These TDD models consist of three primary assemblies; the roof dome assembly, reflective tube assembly and diffuser assembly. These assemblies are detailed in Figure 1 through Figure 4.

3.1.1 Roof Dome Assembly:

Primary components of the dome assembly are the dome, dome ring or tube ring and flashing.

3.1.1.1 A single dome manufactured from impact-resistant acrylic polymer is utilized on Models 160 DS, 290 DS, 300 DS, 330 DS and 750 DS.

3.1.1.2 Models 160 DS, 290 DS, and 750 DS utilize an additional inner dome manufactured from impact resistant acrylic polymer or polycarbonate (750 DS) when installation is within the High Velocity Hurricane Zone as defined by the FBC.



3.1.1.3 A dome ring (160 DS, 290 DS, 300 DS manufactured from impact resistant Acrylic polymer or tube ring (330 DS and 750 DS) manufactured from PVC, connects the inner reflective tube, inner reflector, inner dome and outer dome to the flashing.

3.1.1.4 A corrosion resistant steel dome edge protection band is utilized to protect the dome edge on installations on roof assemblies with fire classifications of A, B or C.

3.1.1.5 Corrosion resistant metal flashings are available in self-mounting, curb-mounting, steep, and low slope roof configurations. For models 160 DS, 290 DS, and 300 DS, the low slope configuration is available in both 4- and 6-inch heights. For models 330 DS and 750 DS, low slope configurations in 4, 8- and 11-inch heights and metal roof flashing are also available. Also, a curb-cap flashing for site-built curb mounting is available for the 290 DS, 300 DS, 330 DS and 750 DS models.

3.1.2 Reflective Tubes:

Reflective tubes and angle adapters have a high reflectance interior tube finish and are manufactured from .015" thick aluminum for 160 DS, 290 DS, and 300 DS, and .018" for 330 DS and 750 DS. Two-inch-wide polymer or aluminum foil tape is utilized at all joints between tube sections and at vertical seams of each tube.

3.1.3 Daylight Dimmer Assembly:

A switch operated, electrically driven Daylight Dimmer Assembly is available for installation above the bottom tube on 160 DS, 290 DS, 300 DS and above the round-to-square transition for 330 DS / 750 DS. The Dimmer Assembly is used to restrict natural light from entering the room. See Section 6.3 and Figure 6.

3.1.4 Light Kit Assembly:

Switch operated, electric light kits are available for installation into the bottom tube for the 160 DS and 290 DS models only. The kits contain either an incandescent or fluorescent light bulb. See Section 6.3 and Figure 5.

3.1.5 Metal Transition Assembly:

Metal transitions are used to transition the reflective tube assembly to the diffuser assemblies. The 300 DS, 330 DS and 750 DS models utilize the transition assembly, manufactured from 0.015-inch-thick aluminum. Two-inch-wide aluminum foil tape is utilized at all joints. See Figure 7 and Figure 8. The 160 DS and 290 DS models utilize the transition assembly shown in Figure 9.

3.1.6 Diffuser and Decorative Fixture Assembly:

The Diffuser and Decorative Fixture assemblies are either single or dual glazed with acrylic or polycarbonate plastic Diffusers classified as a CC2 plastic material. See Figure 10. Diffusers have a flame spread index not exceeding 200 and a smoke development index not exceeding 450 when tested in accordance with ASTM E84. The Aurora Glo lens is comprised of glass.

A dress (trim) ring is mounted over the assembly edge for aesthetic purposes.

For models 160 DS, and 290 DS the standard diffuser and decorative fixtures (JustFrost, OptiView and Tier Drop) employ a ceiling ring that is manufactured from injection molded impact resistant acrylic and is used to connect the reflective tubing and diffusers or decorative fixtures to the interior room ceiling.

The Aurora Glo decorative fixtures employ a fixture mounting ring, in addition to the ceiling ring, that is manufactured from steel and is used to connect the decorative fixture to the interior room ceiling. The ceiling ring is also used to hold the reflective tubing in place.

3.2 Solatube SkyVault Series Model M74 DS consists of four primary assemblies; single or dual glazed skylight assembly, reflective tube assembly, diffuser assembly, and cylindrical light collector. See Figure 13 and Figure 14.

3.2.1 The curb mounted skylight assemblies are comprised of a dome, thermal disc (only for dual glazed skylights), a dome edge protection band, dome clamps, a tube ring, foam plastic insulation with a closed cell foam infiltration seal, and a curb cap with closed cell foam weather strips.





3.2.1.1 The dome is manufactured from TUFFAK-SL sheet, recognized in ICC-ES Evaluation Report, ESR-2728.

3.2.1.2 A thermal disc is utilized in dual glazed skylights, and consists of a 0.040 inch thick PET material, complying with IBC Section 2606.4 with a plastic classification of CC1 or CC2.

3.2.1.3 A dome edge protection band is manufactured from 0.022 inch thick by 7/8 inch wide steel sheet.

3.2.1.4 A dome retainer band, manufactured from 0.031 inch thick steel sheet, with four dome retainer clamps, manufactured from 0.064 inch thick steel sheet, attach the dome and the dome edge protection band to the curb cap.

3.2.1.5 Closed cell foam is utilized between the mating surfaces of the dome and curb cap. Closed cell foam is also utilized between the curb cap and wood curb.

3.2.1.6 A tube ring is a 28-1/2 inch diameter, (minimum) 0.018" thick aluminum sheet metal tube formed with rivets through the overlap seam and with a reflective coating on the interior face. It is utilized to connect the top of an extension tube to the curb cap assembly via interlocking joints. A metal belt and torsion spring clamp secure the interlocking joint assembly.

3.2.1.7 The foam plastic insulation is of 1 inch thickness, manufactured in accordance with TER 1309-03. The foam plastic insulation complies with the code requirements for use in attics and crawl spaces without an ignition barrier and does not require a thermal barrier.

3.2.1.8 The curb cap is manufactured from 0.028 inch steel sheet and is mounted to a roof mounted curb provided by others to form the base of the skylight assembly.

3.2.2 Reflective tube assemblies are comprised of (minimum) 0.018-inch-thick, 28-1/2-inch diameter aluminum tubes with a reflective coating on the interior face of the tube. Tubes have six equally spaced tabs on the ends to enable interlocking with additional tubes, tube rings or diffuser collars. A metal belt and torsion spring clamp are utilized to secure the interlocking joints to secure the assembly.

3.2.3 Daylight Dimmer assembly is switch operated and electrically driven, available for installation between transition tubes on the M74 DS models. The Dimmer Assembly is used to restrict natural light from entering the room. See Section 6.3.3.

3.2.4 The thermal insulation panel assembly includes two thermal disks that are of 0.06-inch plastic sheets complying with IBC Section 803.1 and IBC Section 2606.4 and are available for installation within the reflective tube assembly. The thermal insulation panel is used to add insulation to the tube assembly for increased thermal performance.

3.2.5 Diffuser assemblies are comprised of a prismatic panel diffuser, diffuser collar, and closed cell sponge rubber dress ring.

3.2.6 The prismatic panel diffuser is a single glazed acrylic diffuser with a plastic classification of CC2. The prismatic panel diffuser has twelve evenly spaced holes around its perimeter that fit the tabs of the diffuser collar.

3.2.6.1 A diffuser collar is utilized to connect the bottom of an extension tube to the prismatic panel diffuser. Diffuser collars have six tabs on one end and twelve on the other to enable interlocking with the extension tubes and prismatic panel diffuser, respectively.

3.2.6.2 A closed cell sponge rubber dress ring is snap-fitted around the perimeter of the prismatic panel diffuser

3.2.6.3 Amplifier diffuser assemblies use a tube manufactured of sheet metal that transitions the diffuser from a 28-1/2 inch diameter to 36 inch diameter.

3.2.7 M74 DS Cylindrical Light Collector Assembly is comprised of wire ropes, a cylinder assembly, a dome, clamps, retainers, and rivets. See Figure 14.

3.2.7.1 Wire ropes consist of stranded, 3/32 inch diameter stainless steel ropes, utilized for bracing the height of the cylindrical light collector.

3.2.7.2 The cylinder assembly consists of two primary components: a metal reflector sheet in one half of the cylinder circumference and plastic glazing in the other half. The metal and the plastic sheets are attached with a sheet steel cleat and rivets to assemble a cylindrical shape.





3.2.7.3 The dome is manufactured from TUFFAK SL sheet, recognized in ICC-ES Evaluation Report, ESR-2728.

3.2.7.4 Two types of clamps: Four stainless steel clamps attach the ropes to the top of the cylindrical light collector at the dome, while four sheet steel clamps attach the wire ropes to the curb cap at the corners. A retainer band is used in conjunction with the stainless steel clamps to secure the dome to the top of the cylindrical light collector.

4.0 PERFORMANCE CHARACTERISTICS

4.1 Models identified in this report have been tested for deflection and structural response under uniform loading in both the positive (inward) and negative (outward) directions in accordance with ICC-ES AC16. The maximum allowable positive and negative design pressures for each model size combination, and associated anchoring, are indicated in Table 1 and Table 2.

4.2 Models identified in this report have met the air infiltration and water penetration acceptance criteria identified in ICC-ES AC16 when tested in accordance with Sections 7.2.3 and 7.2.4 of AAMA/WDMA/CSA 101/I.S.2/A440-22.

4.2.1 AAMA/WDMA/CSA101/I.S.2/A440-22 was reviewed and deemed equivalent for compliance with IBC Section 2405.5.

4.2.2 Models 160 DS, 290 DS, and 300 DS have met the air leakage performance and water penetration resistance requirements of A440S1-09, the Canadian Supplement to AAMA/WDMA/CSA 101/I.S.2/A440.

4.3 The M74 DS Cylindrical Light Collector Assembly identified in this report has been tested for lateral static loading to a safety factor of 2.5 in accordance with IBC Section 1709.3.1. The maximum allowable lateral design loads are indicated in Table 3.

4.4 The M74 DS prismatic panel diffusers have a self-ignition temperature of 650°F (343°C) or greater when tested in accordance with ASTM D1929, a smoke development index not exceeding 75 when tested in accordance with ASTM D2843, a plastic classification of CC2

when tested in accordance with ASTM D635 and comply with the installation requirements of IBC Section 2606.7.2.

5.0 INSTALLATION

5.1 General:

Solatube Tubular Daylighting Devices must be installed in accordance with the manufacturer's published installation instructions, the applicable Code, and this Research Report. A copy of the manufacturer's instructions must be available on the jobsite during installation.

5.2 Models 160 DS, 290 DS, 300 DS, 330 DS, 750 DS, 330 DS-O, 750 DS-O, 300 DS-C, 330 DS-C and 750 DS-C:

5.2.1 The dome attachment for the 10" 160 DS, 14" 290 DS, and 14" 300 DS models is accomplished by attaching the dome ring to the flashing and top tube with four (4) #8x1" truss washer head screws and plastic spacers with a snap fit between the dome and dome ring. See Figures 1 and 2.

5.2.2 Diffuser assemblies for the 10" 160 DS, and 14" 290 DS models are comprised of an acrylic ceiling ring, an acrylic dress ring and dual glazed diffuser. The dress ring is snap fitted or twist secured onto the ceiling ring.

5.2.3 The Dome attachment for the 21" 330 DS and 750 DS models is accomplished with three (3) #8x1-5/8" washer head sheet metal screws passing through three (3) equally spaced plastic spacers, flashing and into the tube ring.

5.2.4 The Dome Assembly for the 21" 330 DS-O and 750 DS-O (Open Ceiling) models utilize a butyl putty seal (referred to as a glazing rope in installation instructions) between the flashing and tube ring. See Figure 3 and Figure 4.

5.2.5 For the 14" 300 DS-C, 21" 330 DS-C and 750 DS-C (Closed Ceiling) models, the tube ring should be sealed to the outer face of the top reflector tube with 2" wide polymer/foil tape.

5.2.6 Diffuser assembly for the 21" 330 DS-O and 750 DS-O (Open Ceiling) models is comprised of an acrylic dress ring and a single glazed diffuser. The assembly is snapped into the four (4) equally spaced slots provided in the end of the extension tube.





5.2.7 The 21" 330 DS-C and 750 DS-C (Closed Ceiling) models consist of a square diffuser assembly that connects to the round reflective tube through a square to round transition section.

5.2.8 Installation for compliance with the IBC and IRC shall be in accordance with IBC Section 2405 and 2610 and, IRC Section R324.6 [R308.6].

5.2.9 Installation for compliance with the FBC shall be in accordance with FBC Section 2405 and 2610.

5.2.10 The installation on roof assemblies with fire classifications A, B, or C, metal dome edge protective rings shall be installed on the 160 DS, 290 DS, 300 DS, 330 DS and 750 DS models utilizing the 4" flashings. Other flashings noted in Section 3.1.1.5 may be needed in order to maintain the required minimum 4" distance from roof deck to dome edge.

5.3 Model M74 DS:

5.3.1 Skylights shall be mounted on a wood, steel, aluminum, or concrete curb that raises the plastic glazing at least 4 inches above the plane of the roof.

5.3.2 The outside curb dimensions are indicated in Table 5 and Table 6. The design, attachment, flashing and placement of the curb to the roof deck is outside the scope of this report.

5.3.3 Skylights shall be attached to the curb utilizing fasteners described in this report. See Table 5 and Table 6 for fastener details. A maximum 1/2 inch shim space is permitted between the curb and the curb cap.

5.3.4 The M74 DS cylindrical light collector is attached to the top of the M74 DS curb cap flashing with wire ropes, clamps, and screws. See Figure 14.

6.0 CONDITIONS OF USE

6.1 Installation must comply with this Research Report, the manufacturer's published installation instructions, and the applicable Code. In the event of a conflict, this report governs.

6.2 Models 160 DS, 290 DS, 300 DS, 330 DS, 750 DS, 330 DS-O, 750 DS-O, 300 DS-C, 330 DS-C and 750 DS-C:

6.2.1 Installation shall comply with the manufacturer's installation instructions, this report, IBC and FBC Sections 2405 and 2610 and IRC Section R324.6 [R308.6]. The wind uplift rating recognized in this report (See Table 4) is based on attachment to S-P-F wood curbing (Specific Gravity, $G=0.42$), 5/8" Group 2 Plywood and 22 gauge 33 ksi minimum yield steel deck. Installation on a wood substrate with a lesser specific gravity or lesser thickness may result in a lower wind uplift rating.

6.2.2 The Daylight Dimmer, incandescent light and fluorescent light assemblies were only evaluated for effects on performance when TDDs were tested in accordance with ICC-ES AC16. Evaluation of these assemblies for compliance to electrical codes is not part of this report.

6.2.3 Where required by the building official, engineering calculations and details shall be provided. The calculations shall verify that the anchorage complies with the building code for the type of framing and condition of the supporting construction.

6.2.4 Model 330 DS shall not be installed in High Velocity Hurricane Zones as defined by the Florida Building Code.

6.2.5 Models 160 DS, 290 DS, 300 DS, and 750 DS shall utilize the additional inner dome for use in High Velocity Hurricane Zones as defined by the Florida Building Code.

6.2.6 All products listed in 6.2 are manufactured under a quality control program with inspections by Keystone Certifications, Inc. (IAS AA-714).

6.3 Model M74 DS:

6.3.1 Unless the building is equipped throughout with an automatic sprinkler system in accordance with IBC Section 903.3.1.1, the light diffusing system shall not be installed in the following occupancies and locations:

- Group A with an occupant load of 1,000 or more.
- Theaters with a stage and proscenium opening and an occupant load of 700 or more.
- Group I-2





- Group I-3
- Interior exit stairways and ramps and exit passageways.

6.3.2 The light-transmitting plastic material of the prismatic panel diffuser complies with Section 2606.7.2 of the IBC. The diffuser may be used in all occupancies where it does not exceed 10 percent of the specific ceiling area to which it is attached.

6.3.3 Daylight dimmer assembly has only been evaluated for effects on performance when TDDs were tested in accordance with ICC-ES AC16. Evaluation of these assemblies for compliance with electrical codes is not part of this report.

6.3.4 The wind uplift rating recognized in this report is based on attachment to curbs and corresponding fasteners as described in Table 5 and Table 6.

6.3.5 The status of this report is contingent on the validity of the ICC-ES reports identified herein. The revocation or expiration of any included ICC-ES reports will invalidate this report.

6.3.6 Where required by the building official, engineering calculations and details shall be provided. The calculations shall verify that the anchorage complies with the building code for the type of framing and condition of the supporting construction.

6.3.7 The Solatube SkyVault Series is manufactured under a quality control program with inspections by Keystone Certifications, Inc. (IAS AA-714).

7.0 SUPPORTING EVIDENCE

7.1 Manufacturer's drawings and installation instructions.

7.2 Reports of testing and engineering analysis in accordance with ICC-ES AC16, *Acceptance Criteria for Plastic Glazed Skylights*, approved April 2017.

7.3 Reports of testing to ASTM D1929-20 [-16] *Test Method for determining Ignition Properties of Plastics*.

7.4 Reports of Testing to ASTM E84-21a [-18b, 16], *Test Method for Surface Burning Characteristics of Building Material*.

7.5 Reports of Testing to ASTM D635-18 [-14] *Test Method for Rate of Burning and/or Extent and Time of Burning of Self-Supporting Plastics in a Horizontal Position*.

7.6 Reports of Testing to ASTM G155-13 *Practice for Operating Xenon Arc Light Apparatus for Exposure of Nonmetallic Materials* and ASTM D638 *Test Method for Tensile Properties of Plastics*.

7.7 Documentation of an Intertek approved quality control system for the manufacturing of products recognized in this report.

7.8 Reports of engineering and installation analysis for alternate anchorage signed and sealed by a Professional Engineer registered in the State of Florida.

7.9 Testing for Florida Building Code was performed by a Miami-Dade County approved testing facility (Architectural Testing, Inc. - Fresno, CA) with reports signed and sealed by a Professional Engineer registered in the State of Florida. These reports are:

7.9.1 Reports of testing in accordance with AAMA/WDMA/CSA101/I.S.2/A440-22 [-17], *Standard/Specification for Windows, Doors, and Unit Skylights*, *American Architectural Manufacturers Association*, *Window and Door Manufacturers Association*, and *Canadian Standards Association*.

7.9.2 Reports of testing to Testing Application Standard (TAS) 201-94 *Impact Test Procedures* as required by Section 1626 of the Florida Building Code.

7.9.3 Reports of testing to Testing Application Standard (TAS) 202-94 *Criteria for Testing Impact & Nonimpact Resistant Building Envelope Components Using Uniform Static Air Pressure* as required by Section 1620 of the Florida Building Code.

7.9.4 Reports of testing to Testing Application Standard (TAS) 203-94 *Criteria for Testing Products subject to Cyclic Wind*





Pressure Loading as required by Sections 1625, Table 1625.4 and Table 1626 of the Florida Building Code.

7.10 Reports of testing for 160 DS, 290 DS, and 300 DS models in accordance with A440S1-09, *Canadian Supplement to AAMA/WDMA/CSA 101/I.S.2/A440-11, NAFS – North American Fenestration Standard/Specification for Windows, Doors, and Skylights.*

7.11 Reports of testing in accordance with ASTM E1886-19 [13a], *Standard Test Method for Performance of Exterior Windows, Curtain Walls, Doors, and Impact Protective Systems Impacted by Missile(s) and Exposed to Cyclic Pressure Differentials.*

7.12 Reports of testing in accordance with ASTM E1996-20 [17, 14a] *Standard Specification for Performance of Exterior Windows, Curtain Walls, Doors, and Impact Protective Systems Impacted by Windborne Debris in Hurricanes.*



8.0 IDENTIFICATION

The *Solatube Tubular Daylighting Devices* produced in accordance with this report shall be identified with permanent labeling that includes the following information:

8.1 The manufacturers name and/or logo, address model number and allowable loads

8.2 The plastic dome glazing thickness and classification (CC2 or CC1)

8.3 For M74 DS only, safety labeling indicating “Risk of Fall” that complies with Class 1, ANSI Standard Z35.1 specifications for accident prevention signs.

8.4 The name or logo of the independent inspection agency, Keystone Certifications, Inc. (IAS AA-714)

8.5 The Intertek mark as shown below, and the Code Compliance Research Report number (CCRR-0131).

9.0 FLORIDA BUILDING CODE

9.1 Scope of Evaluation:

The *Solatube Tubular Daylighting Devices* were evaluated for compliance with the *Florida Building Code – Building* and *Florida Building Code – Residential*.

9.2 Conclusion:

The *Solatube Tubular Daylighting Devices*, described in Sections 2.0 through 7.0 of this Research Report, comply with the *Florida Building Code, Including High Velocity Hurricane Zones for 160 DS, 290 DS, 750 DS and M74 DS models.*

9.2.1 Models 160 DS, 290 DS, 300 DS, 330 DS, 750 DS and M74 DS have been tested to show compliance with AAMA/WDMA/CSA 101/I.S.2/A440-11 *Standard Specification for Windows, Doors, and Unit Skylights.* Testing was performed by a Miami-Dade County approved testing facility and were signed and sealed by a Professional Engineer with current registration in the state of Florida.

9.2.2 Light Transmitting Plastics forming part of the models identified in this report have been shown to have a self-ignition temperature greater than 650°F when tested in accordance with ASTM D1929-16, A smoke development index less than 450 when tested in accordance with ASTM E84-18b [16], and a combustibility classification of CC1 or CC2 when tested in accordance with ASTM D635-14.



545 E. Algonquin Road • Arlington Heights • Illinois • 60005

intertek.com/building





9.2.3 High Velocity Hurricane Zones (HVHZ)

Models 160 DS, 290 DS, 300 DS, 750 DS and M74 DS excluding the Cylindrical Light Collector have been additionally tested to show compliance with the requirements of the Florida Building Code for use in locations designated as High Velocity Hurricane Zones. Testing has shown;

9.2.3.1 Sufficient resistance to windborne debris, as stated in Section 1626 of the Florida Building Code when tested to FBC Test Protocol TAS 201-94. Sufficient resistance to wind forces as determined by Section 1620 of the Florida Building Code when tested to FBC Test Protocol TAS 202-94.

9.2.3.2 Sufficient resistance to cyclic wind pressure loading as determined by Sections 1625, Table 1625.4 and Table 1626 of the Florida Building Code when tested to FBC Test Protocol TAS 203-94.

9.2.3.3 The Cylindrical Light Collector is installed on the exterior of the M74 DS skylight and the building envelope. The Cylindrical Light Collector has not been evaluated for windborne debris or cyclic wind pressure loading.

9.2.3.4 Sufficient weathering resistance of plastics with outdoor exposure when tested to ASTM G155-13 for a period of 4500 hours and subsequent testing to ASTM D638-14.

10.0 CODE COMPLIANCE RESEARCH REPORT USE

10.1 Approval of building products and/or materials can only be granted by a building official having legal authority in the specific jurisdiction where approval is sought.

10.2 Code Compliance Research Reports shall not be used in any manner that implies an endorsement of the product by Intertek.

10.3 Reference to the <https://bpdirectory.intertek.com> is recommended to ascertain the current version and status of this report.

This Code Compliance Research Report (“Report”) is for the exclusive use of Intertek's Client and is provided pursuant to the agreement between Intertek and its Client. Intertek's responsibility and liability are limited to the terms and conditions of the agreement. Intertek assumes no liability to any party, other than to the Client in accordance with the agreement, for any loss, expense or damage occasioned by the use of this Report. Only the Client is authorized to permit copying or distribution of this Report and then only in its entirety, and the Client shall not use the Report in a misleading manner. Client further agrees and understands that reliance upon the Report is limited to the representations made therein. The Report is not an endorsement or recommendation for use of the subject and/or product described herein. This Report is not the Intertek Listing Report covering the subject product and utilized for Intertek Certification and this Report does not represent authorization for the use of any Intertek certification marks. Any use of the Intertek name or one of its marks for the sale or advertisement of the tested material, product or service must first be approved in writing by Intertek.



545 E. Algonquin Road • Arlington Heights • Illinois • 60005
intertek.com/building





TABLE 1 – MAXIMUM ALLOWABLE DESIGN LOADS AND APPLICABLE CODES

Model No	Dia. (inch)	Dome Thickness (inch)	IBC, IRC, FBC	
			Performance Grade (PG) Rating Pressure	Maximum Positive Design Pressure ²
160 DS	10	0.125	+/-70 psf	+150 psf
290 DS	14	0.125		
300 DS-C				
330 DS-O ¹	21	0.168		
330 DS-C ¹				
750 DS-O	21	0.210		
750 DS-C				

⁽¹⁾ Models 330 DS are not approved for use in High Velocity Hurricane Zones as defined by the FBC.

⁽²⁾ Not limited by Water Test Pressure. May be compared to load combinations including wind loads, dead loads and snow loads.

Table 2 – M74 DS Curb Mounted Skylight Maximum Allowable Design Loads

Skylight Description			Glazing Description			Performance Grade (PG) Rating Pressure
Model Series	Model No.	Dome Rise (inch)	Glazing Material	Glazing Thickness (inch)	Diameter (inch)	
<i>SkyVault</i> (See Figures 11 and 13)	M74 DS	5-7/8 ⁽¹⁾	TUFFAK SL (ESR-2728)	0.118	28-1/2	80 psf

⁽¹⁾ Dome rise is the height measured from the top surface of the curb cap flashing to the top of the plastic dome.

Table 3 – M74 DS Cylindrical Light Collector Maximum Allowable Design Loads

Description	Cylinder Assembly		Lateral Design Loads (psf) ⁽¹⁾
	Dome Cylinder Plastic (half circumference)	Cylinder Reflector (half circumference)	
<i>SkyVault</i> M74 DS with Cylindrical Light Collector (See Figures 12 and 14)	TUFFAK SL (ESR-2728) 0.093 inch thick	0.028 inch thick sheet steel	69.7

⁽¹⁾ Lateral loads were tested to a safety factor of 2.5 in accordance with IBC Section 1709.3.1 (2012 IBC Section 1710.3.1).





TABLE 4 – ANCHORAGE DESCRIPTIONS FOR RECOGNIZED WIND UPLIFT DESIGN PRESSURES

Model #s	Anchorage	Substrate	Anchor Description and Quantity
160 DS 290 DS 300 DS	Metal Flange to wood curb	SPF (S.G. ≥ .42) wood curb	Qty 8 #10 x 2" Wood Screw
	Metal Flange to wood deck	5/8" Type 2 Plywood	Qty 8 #10 x 2" Wood Screw
		15/32" Type 2 Plywood	
		19/32" Type 2 Plywood	
		7/16" OSB	
	Metal Flange to Metal Curb	22-gauge steel 33ksi Min Yield	Qty 8 #10 TEKS
Metal Flange to Metal Deck	22-gauge steel 33ksi Min Yield	Qty 8 #10 TEKS	
330 DS-O ¹ 330 DS-C ¹ 750 DS-O 750 DS-C	Metal Flange to wood curb	SPF (S.G. ≥ .42) wood curb	Qty 8 #10 x 2" Wood Screw
	Metal Flange to wood deck	5/8" Type 2 Plywood	Qty 16 #10 x 2" Wood Screw
		15/32" Type 2 Plywood	
		19/32" Type 2 Plywood	
		7/16" OSB	
	Metal Flange to Metal Curb	22-gauge steel 33ksi Min Yield	Qty 8 #10 TEKS
	Metal Flange to Metal Deck	22-gauge steel 33ksi Min Yield	Qty 16 #10 TEKS
Alum Flange to Metal Deck (Non-Corrugated Roof Type)	26-gauge steel Roof Deck	Qty 16 4.8mm Zinc-Coated Steel Rivets	

¹ Models 330 DS are not approved for use in High Velocity Hurricane Zones as defined by the FBC.





Table 5 – M74 DS Curb and Fastener Schedule

Outside Curb Dimensions	Curb			Fastener (Curb Cap to Curb)		
	Material	Min. Thickness ⁽¹⁾	Properties ⁽¹⁾	Description	Qty.	Spacing
34-3/8" x 34-3/8"	2x8 Spruce-Pine-Fir	2" Nominal Wood Blocking	Specific Gravity, G=0.42	#8 x 2" Phillips truss head self-pierce sheet metal screw	16	Spaced 2-1/2" and 10" on center from each corner for a total of four fasteners per side.
				#10 x 2" wood screw		
	33 ksi Steel (ASTM A653)	18 Gauge (0.0451")	F _y = 33 ksi F _u = 45 ksi	#10-16 SAE Grade 5 TEKS screw with minimum 3 threads past the curb substrate	16	Spaced 2-1/2" and 10" on center from each corner for a total of four fasteners per side.
	3105-H14 Aluminum	0.0508"	F _{tu} = 25 ksi F _{ty} = 22 ksi	#10-24 300 Series stainless steel sheet metal screw with minimum 3 threads past the curb substrate	16	Spaced 2-1/2" and 10" on center from each corner for a total of four fasteners per side.
Normal Weight Concrete	4"	f' _c = 2,500 psi	3/16" ITW Tapcon Anchor (ESR-2202) with min. embedment of 1-1/2"	16	Spaced 2-1/2" and 10" on center from each corner for a total of four fasteners per side.	

⁽¹⁾ Installation on a curb substrate with a lesser thickness or lesser mechanical properties may result in a lower wind load rating.





Table 6 – M74 DS Collector Assembly, Curb Installation Fastener Schedule

Outside Curb Dimensions	Curb			Fastener (Collector with Curb Cap to Curb)		
	Material	Min. Thickness ⁽¹⁾	Properties ⁽¹⁾	Description	Qty.	Spacing
34-3/8" x 34-3/8"	2x8 Spruce-Pine-Fir	2" Nominal Wood Blocking	Specific Gravity, G=0.42	#8 x 2" Phillips truss head self-pierce sheet metal screw	24	Spaced 2-1/2", 10" and 16-1/2" on center from each corner for a total of six fasteners per side.
				#10 x 2" truss head screw		
	33 ksi Steel (ASTM A653)	18 Gauge (0.0451")	F _y = 33 ksi F _u = 45 ksi	#10-16 SAE Grade 5 TEKS screw with minimum 3 threads past the curb substrate	24	Spaced 2-1/2", 10" and 16-1/2" on center from each corner for a total of six fasteners per side.
	3105-H14 Aluminum	0.0508"	F _{tu} = 25 ksi F _{ty} = 22 ksi	#10-24 300 Series stainless steel sheet metal screw with minimum 3 threads past the curb substrate	24	Spaced 2-1/2", 10" and 16-1/2" on center from each corner for a total of six fasteners per side.
Normal Weight Concrete	4"	f' _c = 2,500 psi	3/16" ITW Tapcon Anchor (ESR-2202) with min. embedment of 1-1/2"	24	Spaced 2-1/2", 10" and 16-1/2" on center from each corner for a total of six fasteners per side.	

⁽¹⁾ Installation on a curb substrate with a lesser thickness or lesser mechanical properties may result in a lower wind load rating.





Table 7 – M74 DS Collector Assembly and Collector to Curb Cap Connection Details

Connection	Fastener (Collector to Curb Cap and Curb Cap to Curb)		
	Description	Qty.	Locations
M74 DS Wire Rope to M74 DS Dome Retainer Band Assembly	#10-24 x 1.25" hex washer head, stainless steel screw with a #10-24 aluminum rivet nut	4	Unions are attached at four locations equidistant along the circumference of the Dome Retainer Band.
	M74 DS Union	4	
M74 DS Dome Ring to M74 DS Dome Cylinder Back to M74 DS Cone Base	M74 DS Dome Ring	1	Eight rivets are placed along the upper edge of the Dome Cylinder Back to connect to the Dome Ring.
	M74 DS Dome Cylinder Back	1	
	M74 DS Cone Base	1	Eight rivets are placed along the lower edge of the Dome Cylinder Back to connect to the Cone Base.
	1/8" diameter x 1/4" Rivet	16	
M74 DS Dome Ring to M74 DS Stanchion to M74 DS Cross Beam to M74 DS Cone Base	M74 DS Dome Ring	1	Two rivets are placed at each end of each Stanchion to connect it to the Cone Base on the bottom and the Dome Ring and Cross Beam at the top.
	M74 DS Stanchion	2	
	M74 DS Cross Beam	2	Two rivets are placed at each end of each Cross Beam to connect it to the Dome Ring and Cylinder Back on one end the Dome Ring at the other end.
	M74 DS Cone Base	1	
	1/8" diameter x 1/4" Rivet	16	
M74 DS Cleat to M74 DS Cylinder Back	M74 DS Cleat	2	Nine rivets are placed along the edge of each Cleat to connect it to the Cylinder Back.
	M74 DS Cylinder Back	1	
	1/8" diameter x 1/4" Rivet	18	
M74 DS Reflector to M74 DS Cylinder Back	M74 DS Reflector	1	Two Rivets are placed along each vertical side of the reflector to connect it to the Cylinder Back.
	M74 DS Cylinder Back	1	
	1/8" diameter x 1/4" Rivet	4	
M74 DS Cylinder Assembly to M74 DS Curb Cap Flashing Assembly	M74 DS Cone Clamp	4	Clamps are located at four locations at the mid-point of each side of the M74 DS Curb Cap Flashing assembly with four Rivets per clamp.
	M74 DS Cone Base	1	
	M74 DS Curb Cap Flashing	1	
	1/8" diameter x 1/4" Rivet	16	

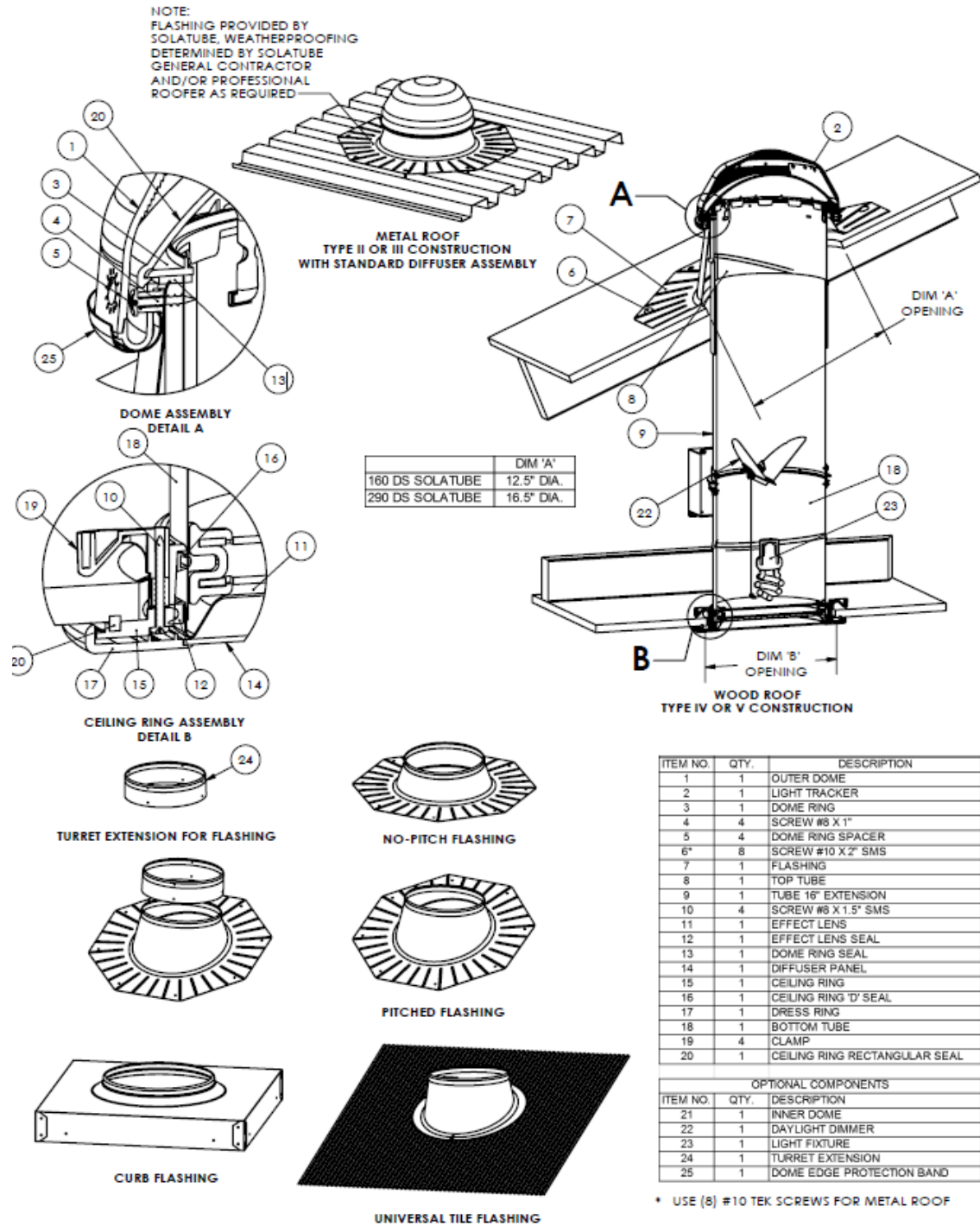

FIGURE 1 - 160 DS AND 290 DS SOLATUBE WITH DETAILS

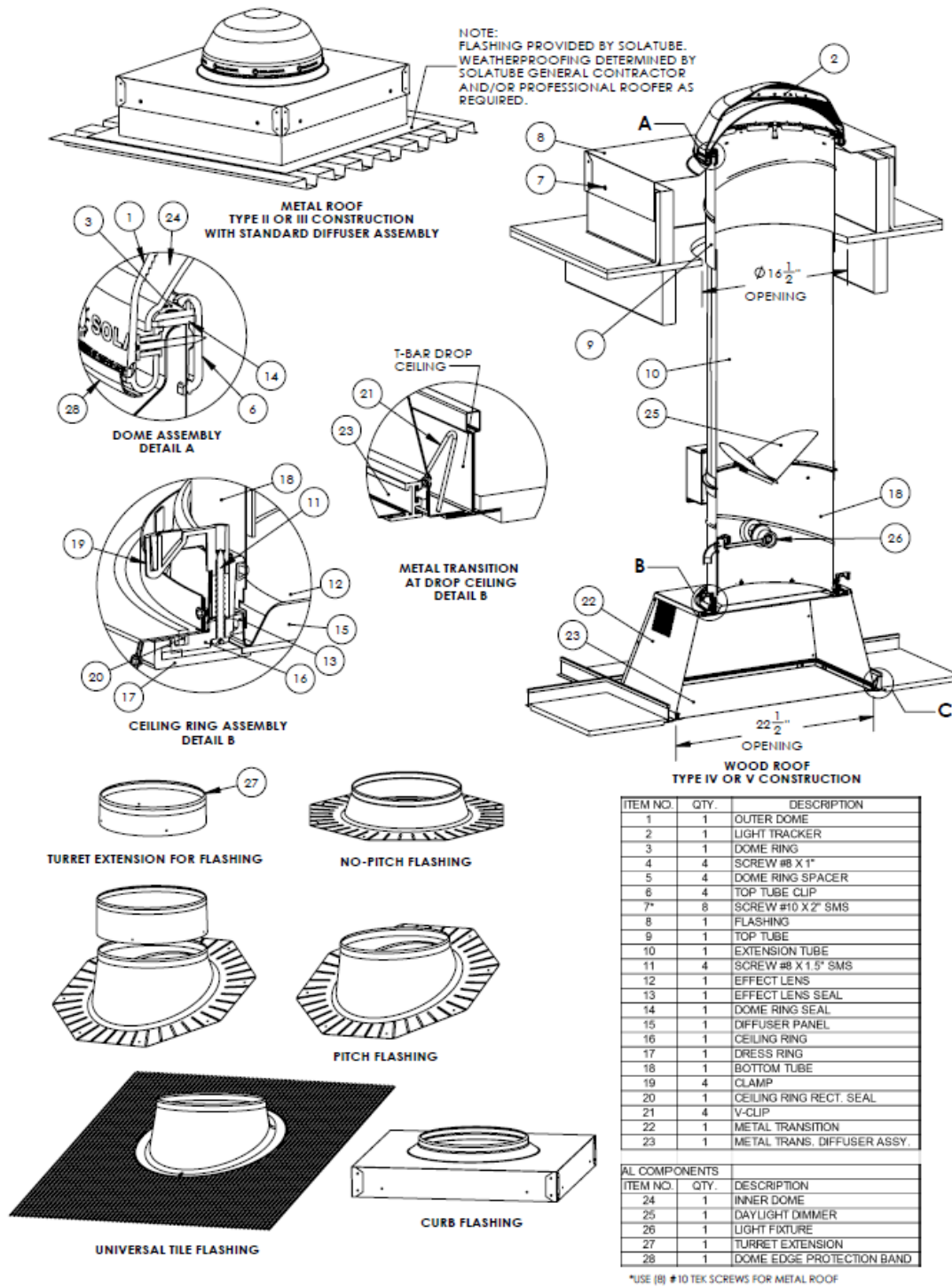

FIGURE 2 - 300 DS SOLATUBE WITH DETAILS

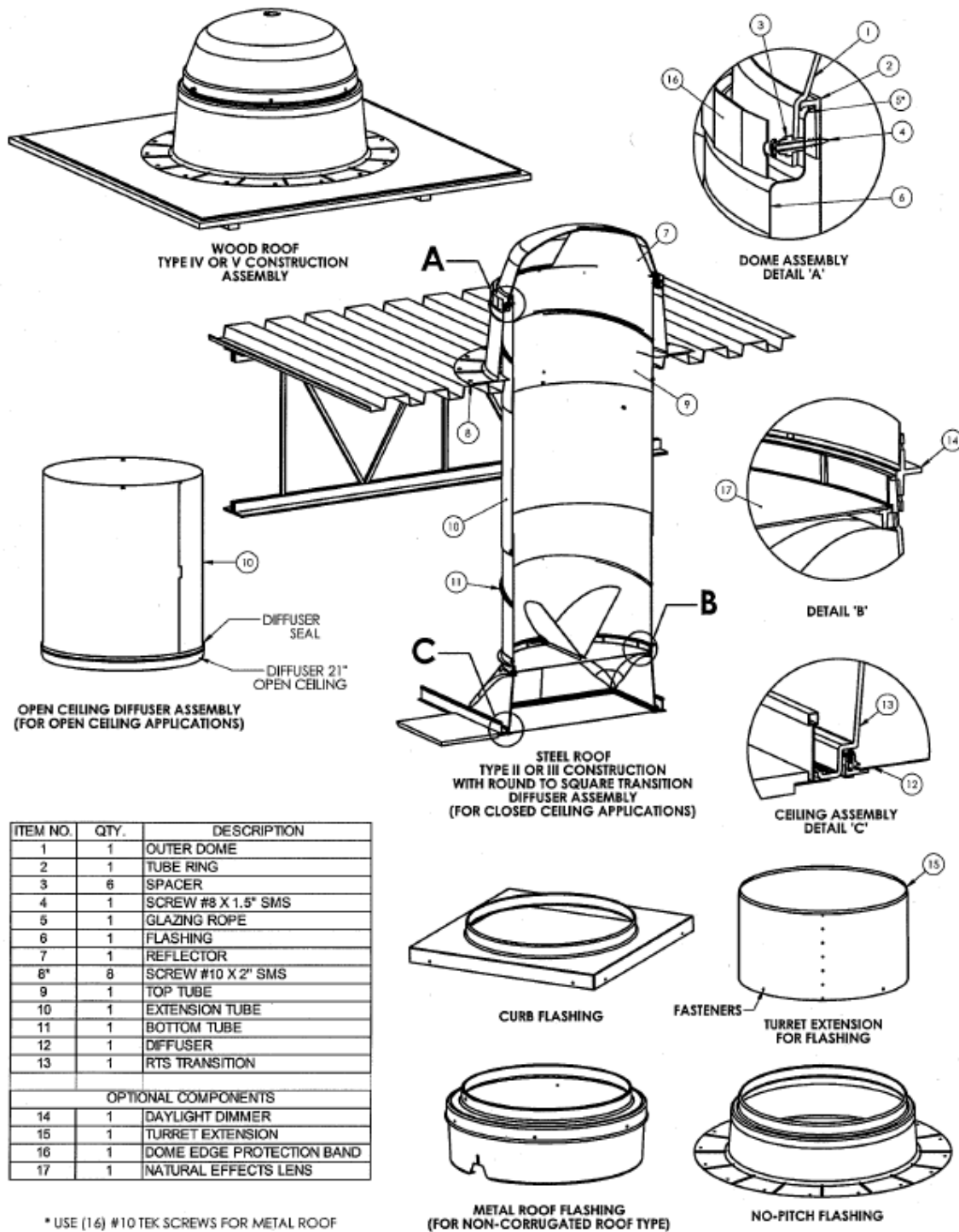
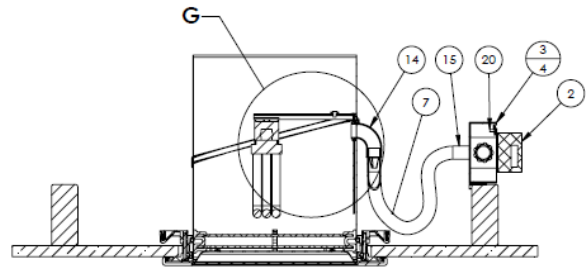
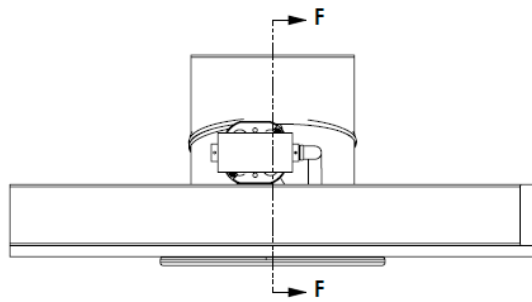
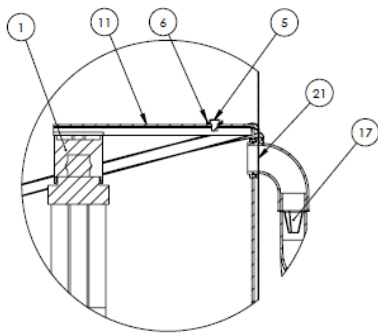

FIGURE 3 - 330 DS SOLATUBE WITH DETAILS



SECTION F-F

ITEM NO.	DESCRIPTION	QTY.
1	LAMP HOLDER 4-PIN	1
2	BALLAST, ELECTRIC 26W	1
3	JUNCTION BOX 4" W/BRACKET	1
4	JUNCTION BOX 4" COVER	1
5	SCREW #8-32 X 1/4"	1
6	WASHER #8 GROUND CUP	1
7	CONDUIT FLEXIBLE 3/8" X 48"	1
8	WIRE LEAD BLACK 18 AWG 62" (NOT SHOWN)	1
9	WIRE LEAD WHITE 18 AWG 62" (NOT SHOWN)	1
10	WIRE LEAD GREEN 18 AWG 62" (NOT SHOWN)	1
11	BRACKET CFL 26 WATT	1
12	ZIP TIE, HELICAL WRAP (NOT SHOWN)	1
13	WASHER FENDER 1/4" X 1-1/4" (NOT SHOWN)	1
14	CONNECTOR 90 DEG 3/8	1
15	CONNECTOR STRAIGHT 3/8	1
16	SCREW HEX #8 X .75" (NOT SHOWN)	4
17	BUSHING ANTI-SHORT RED	1
18	NUT WIRE 73B (NOT SHOWN)	6
19	SLEEVE CRIMP 10-18 GA (NOT SHOWN)	1
20	SCREW GROUND 10-32 X .375	1
21	CONDUIT FOAM SEAL 1/8" H X 3/4"W	4



DETAIL G

Notes:

1. Universal light kit shown assembled to bottom tube.
2. See Figure 1 for upper assembly.
3. Evaluation of these light fixtures for compliance to electrical codes is not part of this report.

FIGURE 5 - TYPICAL SOLATUBE LIGHT KIT ASSEMBLY FOR 160 DS AND 290 DS

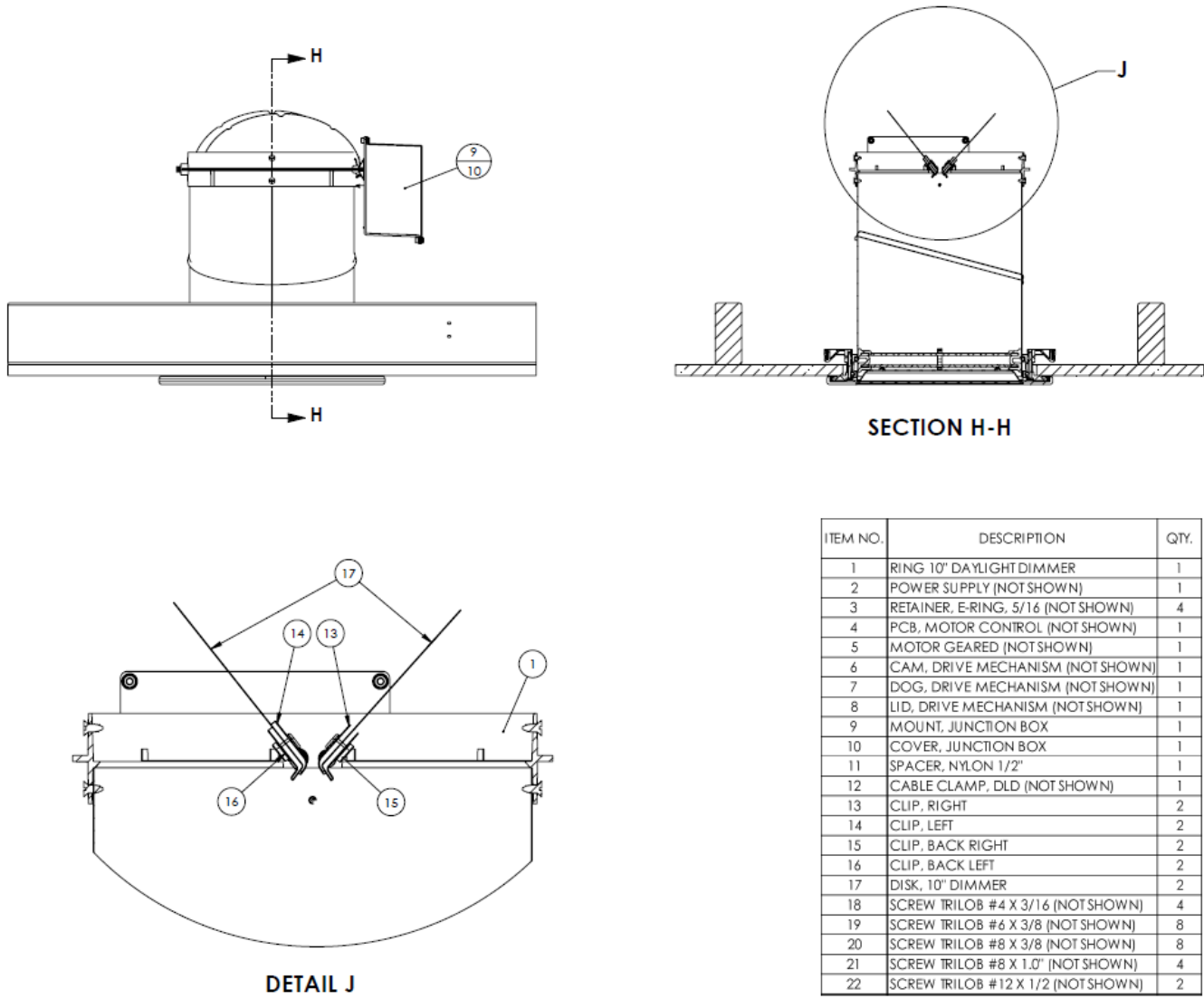

Notes:

- Daylight dimmer kit shown assembled to bottom tube.
- See Figure 1 for upper assembly.
- Evaluation of these light fixtures for compliance to electrical codes is not part of this report.

FIGURE 6 - TYPICAL SOLATUBE DAYLIGHT DIMMER ASSEMBLY FOR 160 DS, 290 DS, 330 DS, AND 750DS

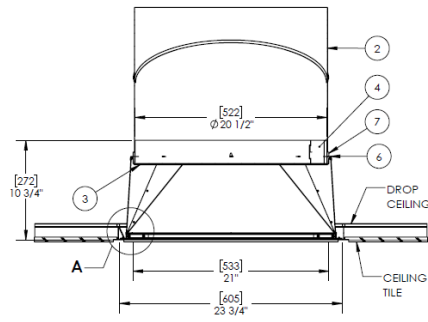

ITEM NO.	QTY.	DESCRIPTION
1	4	CLIP 21" TRANS. HOLD DOWN
2	1	TUBE 21" BOTTOM
3	1	NAT EFFECT LENS 330 DS OTS
4	1	TRANSITION ADAPTER BAND 330/750 DS
5	4	CLIP NAT EFF LENS METAL TRANSITION (NOT SHOWN)
6	1	TRANSITION BOX CAP 330/750 DS
7	1	FOAM SEAL RECTANGLE
8	24	RIVET 1/8 X 1/4 BLIND, MULTI
9	4	TRANSITION TRIM SECTION
10	2	TRANSITION TRIM CORNER BRACE (NOT SHOWN)
11	2	TRANSITION TRIM LEVER
12	10	RIVET 1/8 X 1/4 BLIND, MULTI WHITE
13	4	EXTRUSION ALUM PAINTED MITERED
14	4	CORNER KEY
15	6	SET SCREW 8-32 X 1/8 CLIP PT
16	4	FOAM SEAL T-SLOT .250 X .270
17	1	DIFFUSER PANEL
18	1	TAPE FOAM 21" DIFFUSER
19	4	TRANS PANEL DIMPLED 330/750 DS

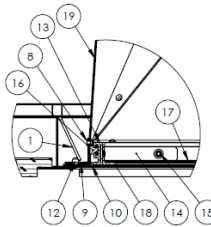

DETAIL A
SCALE 1 : 2

330 DS and 750 DS

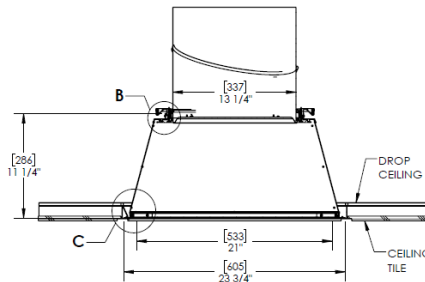

ITEM NO.	QTY.	DESCRIPTION
1	4	CLIP 21" TRANS. HOLD DOWN
2	4	TRANSITION PANEL DIMPLED 300 DS
3	1	TRANSITION BOX CAP 300 DS
4	1	TRANSITION CAP BELT 300 DS
5	33	RIVET 1/8 X 1/4 BLIND, MULTI
6	4	TRANSITION TRIM SECTION
7	2	TRANSITION TRIM CORNER BRACE (NOT SHOWN)
8	2	TRANSITION TRIM LEVER
9	9	RIVET 1/8 X 1/4 BLIND, MULTI WHITE
10	4	EXTRUSION ALUM PAINTED MITERED
11	4	CORNER KEY
12	6	SET SCREW 8-32 X 1/8 CLIP PT
13	4	FOAM SEAL T-SLOT .250 X .270
14	1	DIFFUSER PANEL
15	1	TAPE FOAM 21" DIFFUSER
16	1	CEILING RING 290DS
17	4	SCREW #8 X 1.5"
18	4	FLAG
19	1	D SEAL HOLLOW
20	1	290 DS NATURAL EFFECT LENS
21	1	SEAL
22	1	FOAM SEAL RECTANGULAR 3/16" X 1/4"
26	1	TUBE BOTTOM BLANK 290 DS
27	1	TUBE BOTTOM BLANK 290 DS

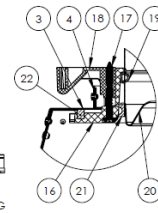

DETAIL B
SCALE 1 : 2

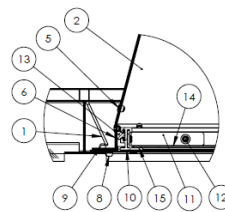

DETAIL C
SCALE 1 : 2

300 DS

FIGURE 7 - TYPICAL SOLATUBE SQUARE TRANSITION ASSEMBLY FOR 300 DS, 330 DS, AND 750 DS



545 E. Algonquin Road • Arlington Heights • Illinois • 60005
intertek.com/building



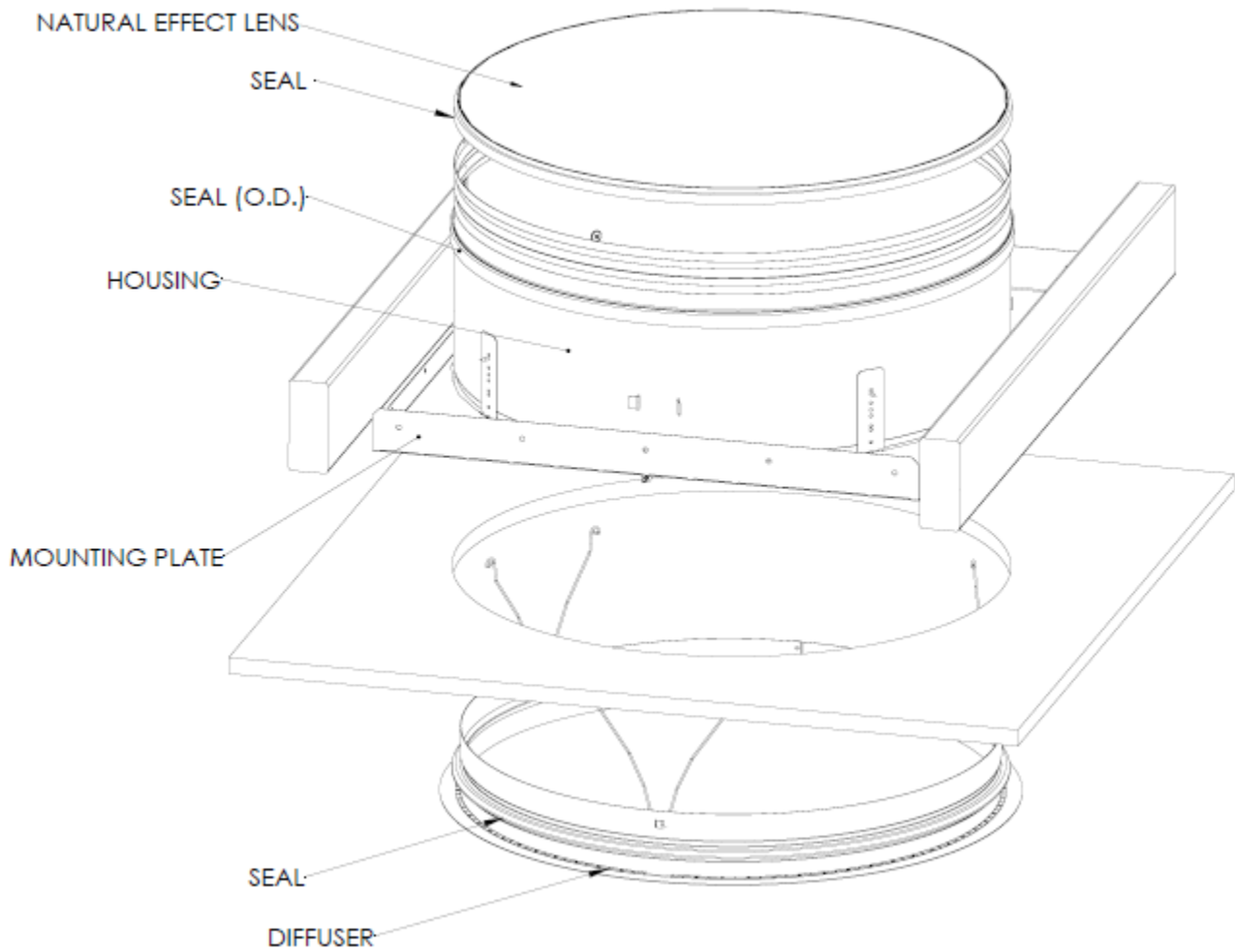

FIGURE 8 - TYPICAL SOLATUBE ROUND TRANSITION ASSEMBLY FOR 300 DS, 330 DS, AND 750 DS

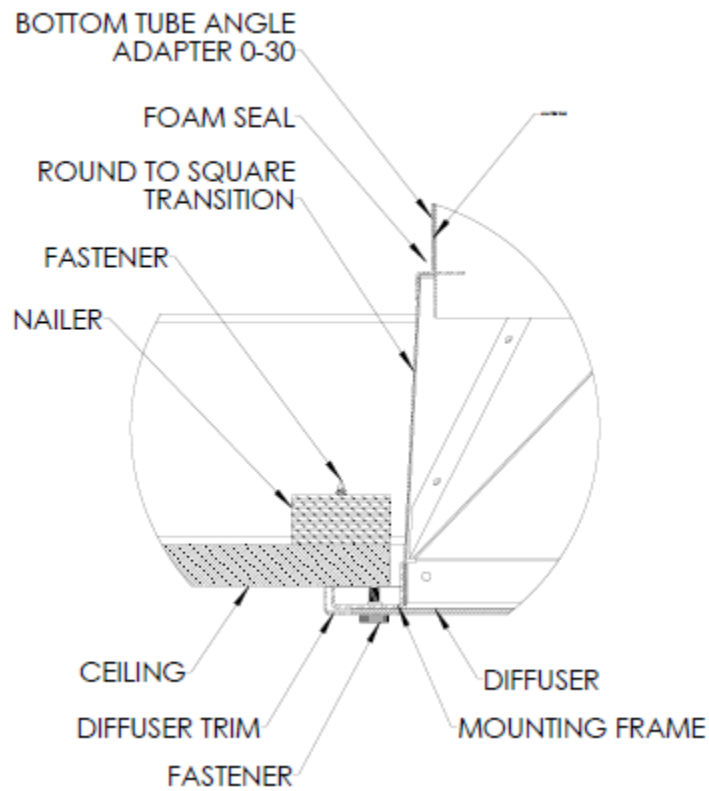
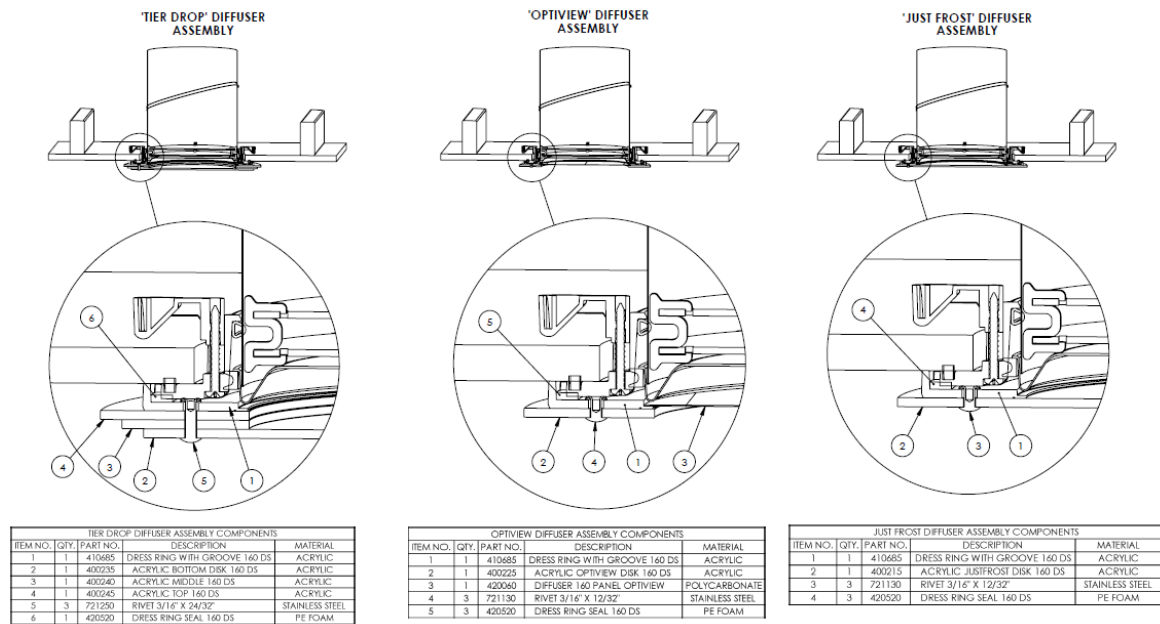
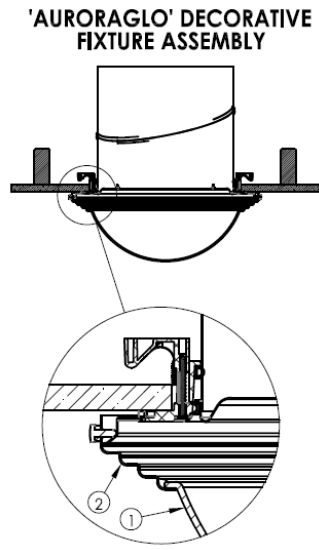

FIGURE 9 - TYPICAL SOLATUBE SQUARE TRANSITION ASSEMBLY FOR 160 DS AND 290 DS



160 DS Decorative Fixture Options



AURORAGLO DECORATIVE FIXTURE ASSEMBLY COMPONENTS		
ITEM NO.	QTY.	DESCRIPTION
1	1	GLASS LENS
2	4	METAL TRIM RING

290 DS Decorative Fixture Options

FIGURE 10 - SOLATUBE 160 DS AND 290 DS DECORATIVE FIXTURES

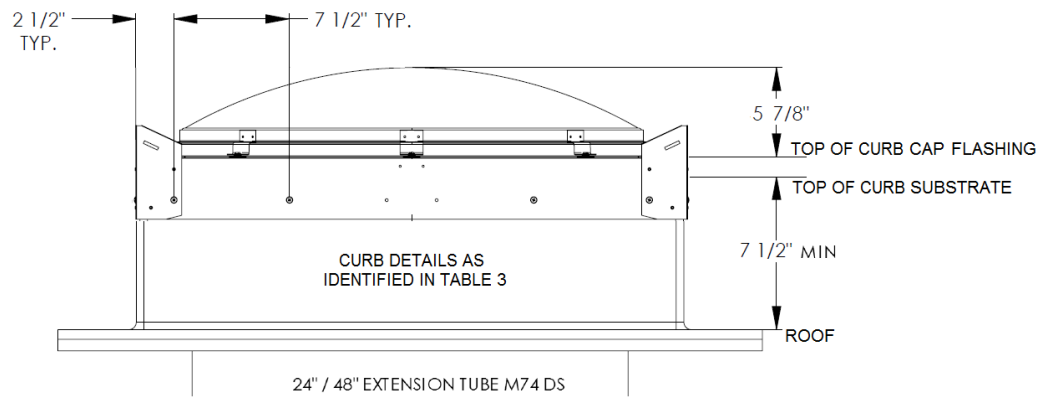

Figure 11 – M74 Curb Dimensions

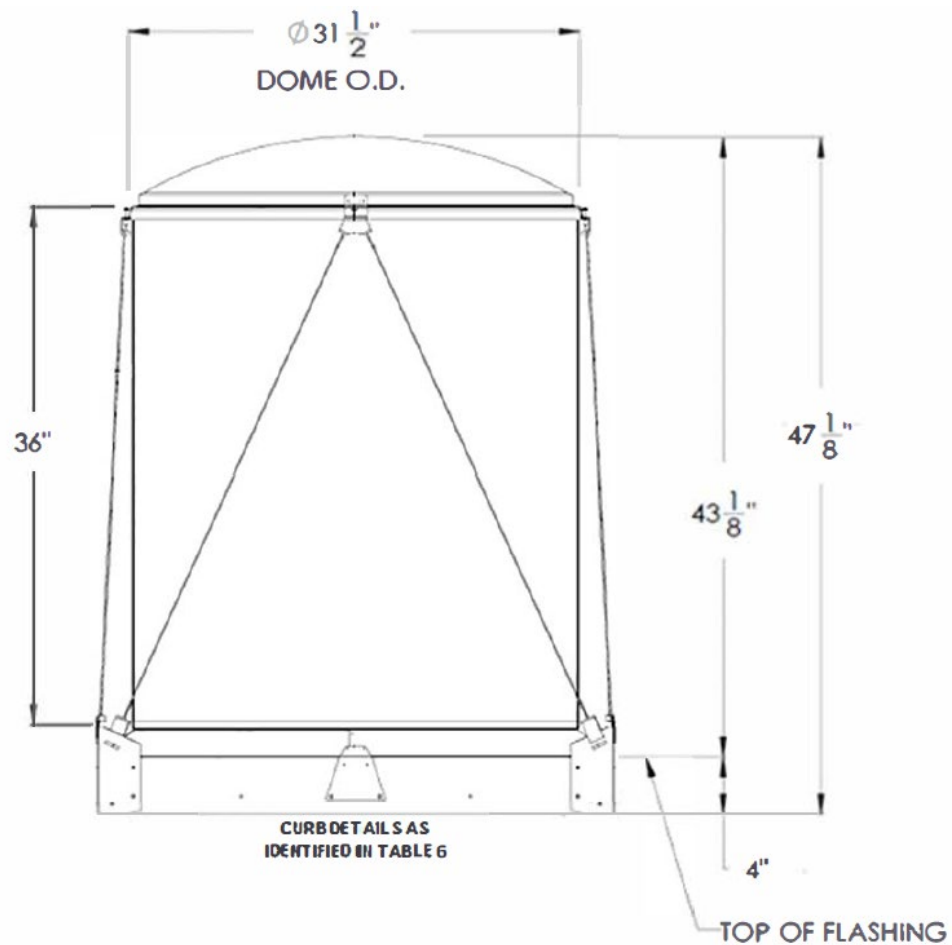
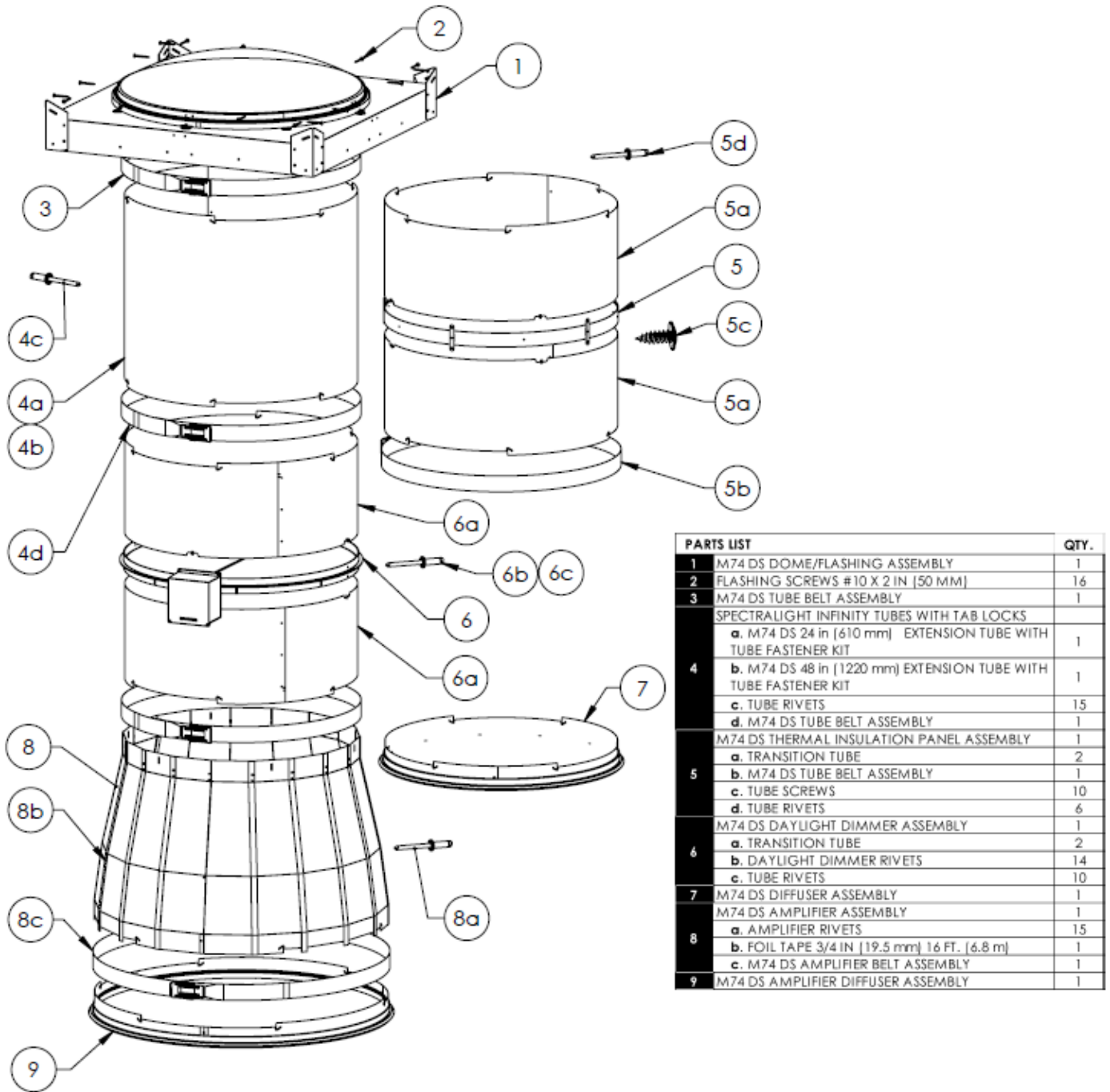

Figure 12 – M74 Cylindrical Light Collector Assembly Dimensions





PARTS LIST	QTY.
1 M74 DS DOME/FLASHING ASSEMBLY	1
2 FLASHING SCREWS #10 X 2 IN [50 MM]	16
3 M74 DS TUBE BELT ASSEMBLY	1
SPECTRALIGHT INFINITY TUBES WITH TAB LOCKS	
a. M74 DS 24 in [610 mm] EXTENSION TUBE WITH TUBE FASTENER KIT	1
b. M74 DS 48 in [1220 mm] EXTENSION TUBE WITH TUBE FASTENER KIT	1
c. TUBE RIVETS	15
d. M74 DS TUBE BELT ASSEMBLY	1
M74 DS THERMAL INSULATION PANEL ASSEMBLY	1
a. TRANSITION TUBE	2
b. M74 DS TUBE BELT ASSEMBLY	1
c. TUBE SCREWS	10
d. TUBE RIVETS	6
M74 DS DAYLIGHT DIMMER ASSEMBLY	1
a. TRANSITION TUBE	2
b. DAYLIGHT DIMMER RIVETS	14
c. TUBE RIVETS	10
M74 DS DIFFUSER ASSEMBLY	1
M74 DS AMPLIFIER ASSEMBLY	1
a. AMPLIFIER RIVETS	15
b. FOIL TAPE 3/4 IN [19.5 mm] 16 FT. [6.8 m]	1
c. M74 DS AMPLIFIER BELT ASSEMBLY	1
9 M74 DS AMPLIFIER DIFFUSER ASSEMBLY	1

Figure 13 – M74 DS Assembly

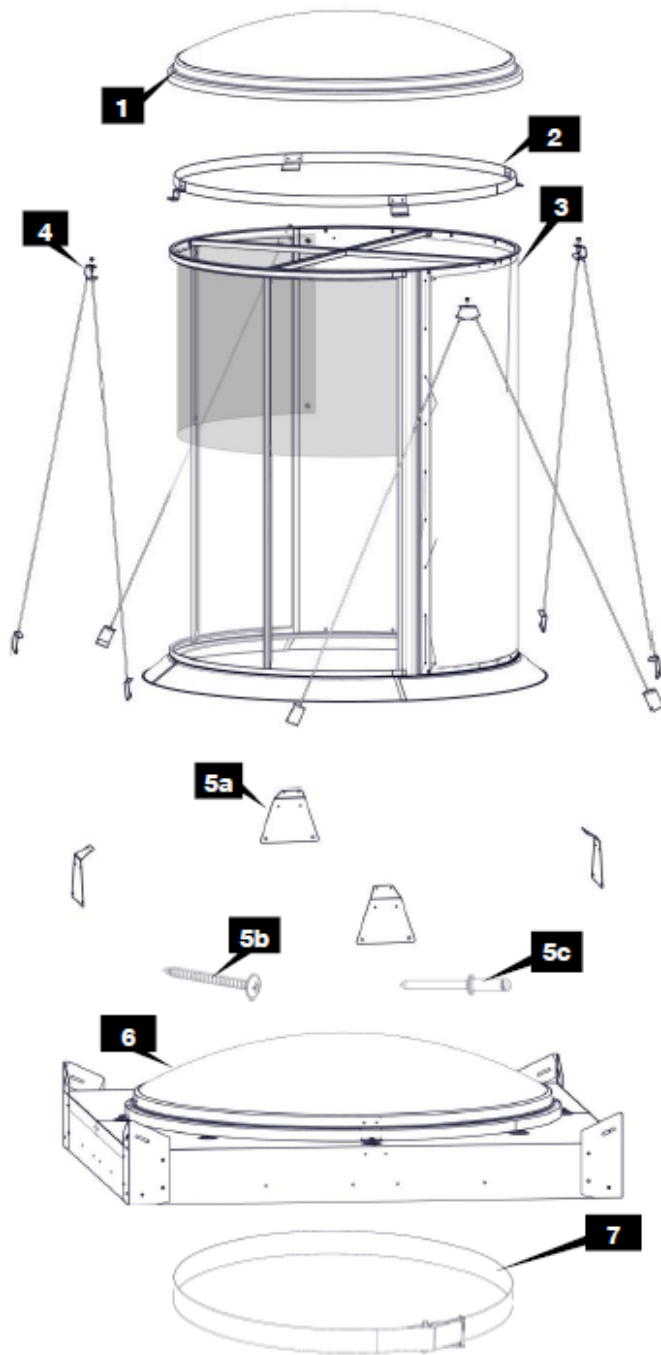

Parts List	Quantity
1 M74 DS Dome	(1)
2 Dome Retainer Band Assembly	(1)
3 M74 DS Cylinder Assembly with Raybender HD	(1)
4 Wire Rope Bridge Assembly	(4)
5 Cone Fastener Kit	
a. Cone Clamp	(4)
b. Flashing Screws - #10 X 2 in (50mm)	(24)
c. Cone Clamp Rivet	(17)
6 Pre-Assembled Roof Assembly Options *	(1)
a. M74 DS Single Dome Roof Assembly with Insulated Curb Cap Flashing *†	
b. M74 DS Dual Dome Roof Assembly with Insulated Curb Cap Flashing *†	
c. M74 DS Single Dome Roof Assembly with Insulated Curb Cap Flashing and Security Guard *†	
d. M74 DS Dual Dome Roof Assembly with Insulated Curb Cap Flashing and Security Guard *†	
7 Tube Belt with Belt Latch	(1)

*† Components shown not included in all kits, see label on box.

Figure 14 – M74 DS with Cylindrical Light Collector Assembly
(Add-on to M74 DS Curb Mounted Unit)



545 E. Algonquin Road • Arlington Heights • Illinois • 60005
intertek.com/building

