

Issue Date: 06-04-2014
Revision Date: 10-11-2024
Renewal Date: 06-30-2025

DIVISION: 05 00 00 – METALS

Section: 05 40 00 – Cold Formed Metal Framing

Section: 05 41 00 – Structural Metal Stud Framing

DIVISION: 09 00 00 – FINISHES

Section: 09 22 16.13 – Non-Structural Metal Stud Framing

REPORT HOLDER:

ClarkDietrich Building Systems, LLC

9050 Centre Pointe Drive, Suite 400

West Chester, OH 45069

513-870-1100

www.clarkdietrich.com

REPORT SUBJECT:

ClarkDietrich™ Structural Studs, Track and PanelTRAK

1.0 SCOPE OF EVALUATION

1.1 This Research Report addresses compliance with the following Codes:

- 2024, 2021, and 2018 *International Building Code*® (IBC)
- 2024, 2021, and 2018 *International Residential Code*® (IRC)
- 2023 and 2020 *Florida Building Code* (FBC) (see Section 9.1)
- 2022 *California Building Code* (CBC) (see Section 9.2)

NOTE: This report references the most recent edition of the Codes cited. Section numbers in earlier editions may differ.

1.2 ClarkDietrich™ Structural Studs, Track and PanelTRAK have been evaluated for the following properties:

- Structural Performance

1.3 ClarkDietrich™ Structural Studs and Track have been evaluated for the following uses:

- Exterior and interior load-bearing applications

1.4 ClarkDietrich™ PanelTRAK has been evaluated for the following uses:

- Exterior and interior load-bearing applications

2.0 STATEMENT OF COMPLIANCE

ClarkDietrich™ Structural Studs, Track and PanelTRAK comply with the Codes listed in Section 1.1, for the properties stated in Section 1.2 and uses stated in Section 1.3, when installed as described in this report, including the Conditions of Use stated in Section 6.0.

2.1 2024 IBC and IRC Evaluation Reports

The Intertek CCRR is an *Evaluation Report* for approval of an alternate material, design, or method of construction in accordance with Section 104.2.3.6.1 of the 2024 IBC and Section R104.2.2.6.1 of the 2024 IRC

3.0 DESCRIPTION

3.1 General – Studs and tracks are produced in accordance with AISI S240, fabricated from steel coil conforming to ASTM A1003 Structural Grade 33 Type H and Structural Grade 50 Type H. The steel has a protective coating meeting the minimum requirements of AISI S240. See Table 2.

3.2 Structural studs are pre-punched with knockouts spaced every 24 inches throughout the stud length and shall not be located less than 10 inches from the end of the member to the near edge of the web knockout. Knockout hole dimensions for stud depths of 2-1/2 inches are 3/4 inch wide and 4 inches tall. For stud depths of 3-1/2 inches or greater, knockout holes are 1-1/2 inches wide and 4 inches tall.

4.0 PERFORMANCE CHARACTERISTICS

4.1 Reference the attached ClarkDietrich™ Building Systems Cold-Formed Structural Framing Product Technical Design Guide for design capacities established in accordance with AISI S100.



4.2 Load-bearing conditions must be checked for stud member end reactions (resulting from allowable heights and loads) and for web crippling per the tables identified in the attached Cold-Formed Structural Framing Product Technical Design Guide.

5.0 INSTALLATION

Installation shall be in accordance with the applicable code and referenced AISI standards therein for cold-formed steel light-frame construction, including IBC Section 2206, FBC-B Section 2211, CBC Section 2211, and Sections R505, R603, and R804 of the IRC, FBC-R, and CRC.

6.0 CONDITIONS OF USE

6.1 Installation must comply with this Research Report, the manufacturer’s published installation instructions, and the applicable Code. In the event of a conflict, this report governs.

6.2 All designs and calculations shall be prepared by a licensed design professional according to the requirements in the jurisdiction where the project is located.

6.3 Jobsite manufacturing of studs or tracks is outside the scope of this report.

6.4 Wall studs subjected to lateral loads not tabulated shall be designed using the section properties per Section 4.1 of this report and the AISI specification.

6.5 The minimum base steel thickness of the section delivered to the jobsite must be a minimum of 95% of the design thickness.

6.6 ClarkDietrich™ Structural Studs, Track and PanelTRAK are manufactured under a quality control program with inspections by Intertek Testing Services NA, Inc.

7.0 SUPPORTING EVIDENCE

7.1 Manufacturer's drawings and installation instructions.

7.2 ClarkDietrich Cold-Formed Structural Framing Products Technical Design Guide effective 06/01/2024.

7.3 ClarkDietrich PanelTRAK Cold-Formed Structural Framing Products Technical Design Guide effective 02/25/22.

7.4 Reports of testing and engineering analysis in accordance with ICC-ES AC46, Acceptance Criteria for Cold-formed Steel Framing Members, October 2019, editorially revised December 2020. See Table 1 Code Referenced Standards for a list of the code referenced standards reviewed and deemed equivalent with code editions listed in this report.

7.5 Reports of evaluation and engineering analysis in accordance with AISI S100-16(2020) w/S2-20, North American Specification for the Design of Cold-Formed Steel Structural Members.

7.6 Documentation of an Intertek approved quality control system for the manufacturing of products recognized in this report.

8.0 IDENTIFICATION

The ClarkDietrich™ Structural Studs, Track and PanelTRAK are identified with:

- The manufacturer’s name (ClarkDietrich Building Systems, LLC);
- Address and telephone number;
- The product name (ClarkDietrich™ Structural Studs, Track and PanelTRAK);
- The size and member designation;
- Minimum base steel thickness (uncoated) in decimals or mils;
- Yield Strength;
- Galvanization coating designation: CP60 or CP90; and
- The Intertek Mark as shown below, with the Code Compliance Research Report number (CCRR-0206).





9.0 OTHER CODES

9.1 FLORIDA BUILDING CODE

9.1.1 Scope of Evaluation: The ClarkDietrich™ Structural Studs, Track and PanelTRAK were evaluated for compliance with the 2023 and 2020 *Florida Building Code – Building and Florida Building Code – Residential*.

9.1.2 Conclusion: Conclusion: The ClarkDietrich™ Structural Studs, Track and PanelTRAK, described in Sections 2 through 7 of this Research Report, comply with the 2023 and 2020 *Florida Building Code – Building and Florida Building Code – Residential*, including the High-Velocity Hurricane Zone provisions. For construction governed by the FBC High Velocity Hurricane Zone (HVHZ), the interior wall heights are limited to the heights at the L/240 and L/360 deflection levels.

Intertek is an approved evaluation entity and quality assurance entity pursuant to Florida Statute 553-842 – *Product Evaluation and Approval*.

9.2 CALIFORNIA BUILDING CODE

9.2.1 Scope of Evaluation: The ClarkDietrich™ Structural Studs, Track and PanelTRAK were evaluated for compliance with the 2022 *California Building Code* and *California Residential Code*.

9.2.2 Conclusion: The ClarkDietrich™ Structural Studs, Track and PanelTRAK, described in Sections 2 through 7 of this Research Report, comply with the 2022 *California Building Code* and *California Residential Code*.

10.0 CODE COMPLIANCE RESEARCH REPORT USE

10.1 Approval of building products and/or materials can only be granted by a building official having legal authority in the specific jurisdiction where approval is sought.

10.2 Code Compliance Research Reports shall not be used in any manner that implies an endorsement of the product by Intertek.

10.3 Reference to the <https://bpdirectory.intertek.com> is recommended to ascertain the current version and status of this report.

This Code Compliance Research Report ("Report") is for the exclusive use of Intertek's Client and is provided pursuant to the agreement between Intertek and its Client. Intertek's responsibility and liability are limited to the terms and conditions of the agreement. Intertek assumes no liability to any party, other than to the Client in accordance with the agreement, for any loss, expense or damage occasioned by the use of this Report. Only the Client is authorized to permit copying or distribution of this Report and then only in its entirety, and the Client shall not use the Report in a misleading manner. Client further agrees and understands that reliance upon the Report is limited to the representations made therein. The Report is not an endorsement or recommendation for use of the subject and/or product described herein. This Report is not the Intertek Listing Report covering the subject product and utilized for Intertek Certification and this Report does not represent authorization for the use of any Intertek certification marks. Any use of the Intertek name or one of its marks for the sale or advertisement of the tested material, product or service must first be approved in writing by Intertek.





TABLE 1 – CODE REFERENCED STANDARDS

2024 and 2021 IBC and IRC	2018 IBC and IRC	2023 FBC	2020 FBC	2022 CBC
AISI S100-16(2020) w/S2-20 AISI S240-20	AISI S100-16 AISI S240-15	AISI S100-16(2020) w/S2-20 AISI S240-20	AISI S100-16 AISI S240-15	AISI S100-16(2020) w/S2-20 AISI S240-20

TABLE 2 – COATING DESIGNATIONS

Coating Designator	Minimum Coating Requirements			
	Zinc-Coated ^A oz/ft ² (g/m ²) ^E	Zinc Iron ^B oz/ft ² (g/m ²) ^E	55% Al-Zinc ^C oz/ft ² (g/m ²) ^E	Zinc-5% ^D oz/ft ² (g/m ²) ^E
CP 60	G 60 [Z180]	A 60 [ZF 180]	AZ 50 [AZM 150]	GF 30 [ZGF 90]
CP 90	G 90 [Z275]	Not Applicable	AZ50 [AZM 150]	GF 45 [ZGF 135]

^A Zinc-coated steel sheet described in Specification A653 / A653M.

^B Zinc-iron alloy-coated steel sheet as described in Specification A653 / A653M.

^C 55% Aluminum-zinc alloy-coated steel sheet as described in Specification A792 / A792M.

^D Zinc-5% aluminum alloy-coated steel sheet as described in Specification A875 / A875M.

^E The SI (metric) values given in parentheses are provided for information purposes only.



**STRONGER
THAN STEEL.SM**

MEMBER PROPERTIES & SPANS • CURTAIN WALLS • LOAD-BEARING WALLS • JOISTS • FRAMING DETAILS

IN CONFORMANCE WITH: AISI S100-16 (2020) w/S2-20 North American Specification • International Building Code (IBC) 2024

STRUCTURAL STEEL
FRAMING SYSTEMS



ClarkDietrich
THE FUTURE OF STEEL FRAMING
TAKES FORM

The properties of cold-formed steel are impressive,

and the applications are many. But when you add in the product scope, design innovations and technical expertise that a company like ClarkDietrich alone can provide, the opportunities before you take on an entirely new dimension.

Due to our long history and core competency in steel framing, we can provide an unparalleled level of in-depth knowledge—not only to help you meet the codes, but to surpass expectations for cost-effective, high-performance solutions in today’s commercial and residential buildings.

This publication is specifically designed to help you as a contractor, engineer or architect find the right steel framing components for your projects. What’s more, we’ve worked to make this the industry’s most comprehensive technical support document for cold-formed steel framing.

It’s exactly the kind of resource you’d expect from a partner like ClarkDietrich. Yes, we’re known as a manufacturer of extensively tested, code-compliant steel framing products. But we also offer products that perform as a system, we support a range of efforts for smarter installation and design, and we provide the expertise of a versatile engineering services team—and all on a nationwide scale.

In the following pages, you will find ample information, data and notes to reliably guide your decisions. But please feel free to contact us at any time for additional clarity or support.

Need Product Submittals?

Use **SubmittalPro®** at clarkdietrich.com.

While this document is quite comprehensive, it does not completely cover our vast and growing lineup of products. You will find more complete information on each member selection, as well as nonstandard products, at clarkdietrich.com.

Need help with product selection, ordering, scheduling, delivery, or anything else?

Call us at **800-543-7140**, or on the West Coast at **800-365-5284**.

TABLE OF CONTENTS

Product information	4
General notes	5
Physical & structural properties	6-17
Overview	6-7
Stud/Track properties	8-17
Stud shear & track shear	18
Allowable stud shear	18
Allowable track shear	18
Allowable wall heights	19-39
Interior wall heights	20-26
Exterior curtain wall overview	27
Curtain wall heights	28-39
Allowable axial & lateral loads	40-60
Overview	41
Allowable combined axial & lateral loads	42-55
Allowable unbraced axial loads	56-60
Floor joist framing	61-88
Overview	62
Floor joist span tables	63-88
Allowable web crippling loads	89-92
Overview	90
Allowable web crippling loads—single members	91
Allowable web crippling loads—built-up members	92
Reference	93-99
Fastening options	94
Typical construction details	95-98
Material certification	99
Manufacturing and sales locations	99

How to identify our products.

ClarkDietrich has adopted standard nomenclature established by the American Iron and Steel Institute (AISI) for identifying each of its products. Coding of each member consists of four parts, in this order:

- A number which identifies the web depth of the member to two decimal places. 600 = 6.00," 1000 = 10.00," 550 = 5.50," 362 = 3.625," etc.
- A letter that tells you the type of member, such as S = Stud/joist, T = Track, U = U-channel, and F = Furring channel.
- A number that defines the flange dimension in inches to two decimal places. 162 = 1.625," 200 = 2.00," 125 = 1.25," etc.
- A number following a hyphen that denotes the minimum delivered thickness in mils (33mils = 33/1000 inches which is approximately 0.0329"). Minimum delivered thickness is 95% of design thickness.

Product availability.

Most products manufactured by ClarkDietrich are readily available in all markets, but there can be exceptions. Please contact your ClarkDietrich Sales Representative to make sure the product you need is available in your market area.

Protective coatings.

Structural framing products are available with a variety of protective coatings that meet the CP60 coating protection level requirements of AISI S240. These coatings may include G60, A60, AZ50 or GF30, all of which satisfy the above referenced standards. CP90 coatings are an enhanced option that can be requested for highly corrosive environments. ClarkDietrich can supply a specific or enhanced coating to meet specific project requirements when requested. The buyer is solely responsible to assure that product is ordered to properly satisfy the applicable code or specification.

Example: 362S162-43 (33ksi, CP60) punched

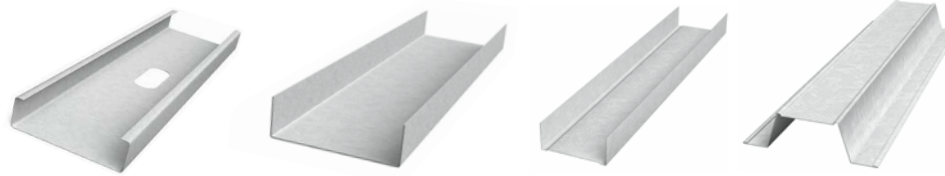

S = Structural stud or joist

T = Structural track

U = CRC or U-channel

F = Furring channel

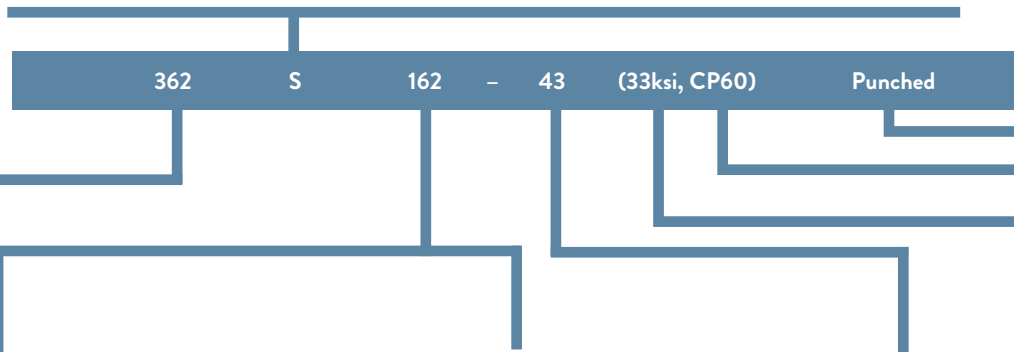

- Punching**
Punched studs or joists will be supplied unless the customer indicates unpunched material is required at time of order. All track and channels are unpunched.
- Protective Coating**
Structural framing CP60 (G60, CP90 & G90 available)
- Yield Strength (Fy)**
33ksi or 50ksi steel (See note 3 below)

ClarkDietrich structural member depths, flanges & available thickness

Member depths	Flange widths range	Mils range	Gauge range
(250) 2-1/2"	1-3/8", 1-5/8", 2" & 2-1/2"	33-68	20-14 ga
(350) 3-1/2"	1-3/8", 1-5/8", 2" & 2-1/2"	33-68	20-14 ga
(362) 3-5/8"	1-3/8", 1-5/8", 2" & 2-1/2"	33-97	20-12 ga
(400) 4"	1-3/8", 1-5/8", 2" & 2-1/2"	33-97	20-12 ga
(550) 5-1/2"	1-5/8", 2" & 2-1/2"	33-97	20-12 ga
(600) 6"	1-3/8", 1-5/8", 2", 2-1/2" & 3"	33-97	20-12 ga
(800) 8"	1-3/8", 1-5/8", 2", 2-1/2" & 3"	33-97	20-12 ga
(925) 9-1/4"	1-5/8", 2" & 2-1/2"	43-97	18-12 ga
(1000) 10"	1-5/8", 2", 2-1/2" & 3"	43-97	18-12 ga
(1200) 12"	1-5/8", 2", 2-1/2" & 3"	54-97	16-12 ga
(1400) 14"	1-5/8", 2", 2-1/2" & 3"	54-97	16-12 ga

ClarkDietrich return lip dimensions

Member	Flange Width (in)	Lip Length (in)
S137 (1-3/8")	1.375	0.375 (3/8")
S162 (1-5/8")	1.625	0.500 (1/2")
S200 (2")	2.000	0.625 (5/8")
S250 (2-1/2")	2.500	0.625 (5/8")
S300 (3")	3.000	0.625 (5/8")

ClarkDietrich thickness identification and color coding

Designation thickness Mils (ga)	Minimum Thickness ¹ (in)	Design Thickness ¹ (in)	Design Inside Corner Radii ² (in)	Color code
33 (20g)	0.0329	0.0346	0.0764	White
43 (18g)	0.0428	0.0451	0.0712	Yellow
54 (16g)	0.0538	0.0566	0.0849	Green
68 (14g)	0.0677	0.0713	0.1069	Orange
97 (12g)	0.0966	0.1017	0.1525	Red

Old stud/track designations

Old designation	Type	Flange/leg
CWN	Stud	1-3/8"
CSJ	Stud	1-5/8"
CSW	Stud	2"
CSE	Stud	2-1/2"
CSS	Stud	3"
TSB	Track	1-1/4"
TSC	Track	2"
TSE	Track	3"

- ¹ Minimum thickness represents 95% of the design thickness and is the minimum acceptable thickness delivered to the job site based on AISI S100-16 (2020) w/S2-20.
- ² The section properties are calculated based on inside corner radii listed in this table. The inside corner radius is the maximum of 3/32-t/2 or 1.5t, truncated after the 4th decimal place (t = design thickness.) Centerline bend radius is calculated by adding half of the design thickness to listed corner radius.
- ³ 33mil (20ga) and 43mil (18ga) framing products are produced with 33ksi steel. 54mil (16ga), 68mil (14ga) and 97mil (12ga) products are produced with 50ksi steel unless otherwise noted.

Complies with AISI S100-16 (2020) w/S2-20 • IBC 2024

The technical content of this literature is effective 06/01/24 and supersedes all previous information.

Support tools

Technical Service.

Technical Service is the most important way we serve our present and prospective customers. After all, your experience with our products will only be a good one if you are satisfied that the material is right for the job and that it is being installed correctly. That's why we have provided four ways to make sure you can get the Technical Service you need.

Web support—www.clarkdietrich.com contains information on the company, its products and a wealth of other information related to the steel framing industry. This website also provides you with more detailed information about all of the company's products, including load and limiting heights tables for member sizes and configurations not contained in this printed manual. Please visit this site to familiarize yourself with what we have to offer.

ClarkDietrich iTools and SubmittalPro®—While this Design Guide is quite comprehensive, it does not completely cover our vast and growing lineup of products or design tables. To keep the catalog from being overloaded, it only includes half the design tables our online tools can offer. Please consider using ClarkDietrich iTools found on the top menu bar of www.clarkdietrich.com

ClarkDietrich iTools includes:

- SubmittalPro®
- Lookup Tools for ProSTUD, Structural Framing and Shaftwall Framing
- Clip Express Navigation
- CAD Library
- Cost Savings Calculators

ClarkDietrich Engineering Services—A full-service design and engineering firm that provides certified engineering shop drawing packages. ClarkDietrich Engineering Services is licensed throughout the United States and can be reached by calling 877-832-3206.

ClarkDietrich Technical Services—For general technical service on products, member sizing, industry standards, framing details or information on engineering software, please call technical services at 888-437-3244.

Architectural specification review.

Over time, project specifications can become outdated. For suggestions on how to improve the performance of your specifications, contact us about a complimentary review at 330-974-0835.

Catalog notes

Standards and specifications.

All members comply with ASTM standards shown in the Material Certification at the back of this catalog. All structural properties are developed in accordance with the American Iron and Steel Institute's "Specification for the Design of Cold-Formed Steel Structural Members, S100-16 (2020) w/S2-20."

General notes.

The data contained in this catalog is intended to be used as a general guideline only and does not replace the judgment and designs of a qualified architect and/or engineer.

Product, application renderings and photographs are provided as a tool to show the general intent of the framing or finishing application only. These renderings or photographs may or may not be applicable to a specific project. They do not replace or supercede the architect or engineer of record, AISI or ASTM guidelines, U.S. national or local building codes, or approved industry standards.

ClarkDietrich reserves the right to change or modify the information contained in this catalog without prior notice or obligation. The information in this catalog supercedes all previously published data. Products and systems may be improved and/or changed after this catalog is printed.

All products described here may not be available in all geographic markets. Consult your local sales office for information.

Warranty.

ClarkDietrich warrants that all products are free from defect at time of shipment, and are manufactured in accordance with company and/or industry standards as applicable.

NOTICE: ClarkDietrich shall not be liable for incidental and consequential damages, directly or indirectly sustained, nor for any loss caused by application of these goods not in accordance with current printed instructions or for other than the intended use. Our liability is expressly limited to replacement of defective goods. Any claim shall be deemed waived unless made in writing to us within thirty (30) days from date it was or reasonably should have been discovered.

Overview

Steel framing is engineered to take advantage of the physical properties of formed steel to provide strength where needed and as needed in the construction of buildings. This section provides the basic information needed by architects and engineers to make sure the member called for in the plans will meet the criteria required by the structure.

Structural framing general notes.

- 1 Physical properties have been calculated in conformance with AISI S100-16 (2020) w/S2-20.
- 2 Effective properties of structural framing incorporate the strength increase from the cold work of forming as applicable per AISI S100-16 (2020) w/S2-20.

- 3 Gross properties are based on the cross-section away from web punchouts. Effective properties are based on knockout/punched sections.
- 4 The effective moment of inertia for deflection is calculated at a stress which results in a section modulus, such that the stress times the section modulus such that stress is equal to the allowable moment. AISI S100-16 (2020) w/S2-20 Procedure for serviceability determination has been used.

LEED® Services

BUILD GREEN with ClarkDietrich Building Systems

ClarkDietrich Building Systems is an active member of the U.S. Green Building Council and is committed to supplying quality products that are environmentally responsible. We are continually working to develop greener building products and sustainable business practices. ClarkDietrich steel framing helps contribute points toward LEED® certification. For more details contact Technical Services at 888-437-3244 or visit www.clarkdietrich.com/LEED.

Symbols and terms.

The following tables are provided to help architects and engineers design structures that withstand various forces. Those forces include vertical loads such as weight from overhead, lateral loads such as wind, other applied pressure or a combination of those. Such natural forces can result in deflection and/or twisting of cold-formed steel framing members.

Key among these tables are the physical and structural properties tables in this next section. The tables provide typical data required to make determinations about the suitability of materials for certain intended purposes. The data is identified by commonly used engineering symbols and terms. This legend will help you to understand the symbols and terms used here.

- I_x = (in⁴): Moment of inertia about the X-X axis, used for DEFLECTION
- S_x = (in³): Section modulus about the X-X axis, used for STRESS & LOADS
- R_x = (in): Radius of gyration about the X-X axis
- I_y = (in⁴): Moment of inertia about the Y-Y axis
- R_y = (in): Radius of gyration about the Y-Y axis, used for AXIAL LOADS

Wind load (lbs/sq ft): Forces produced by wind, either direct wind (positive pressure), a vacuum (negative pressure) or those generated by wind whipping around the corners of a building. These forces are usually calculated according to the prevailing building code. Wind forces are referred to as transverse loads, are perpendicular to the wall, and cause the wall to deflect.

Axial load (lbs): A vertical force produced by overhead loads, such as floors and roof. Floors and roofs contain both dead loads and live loads, which combine to make up the vertical loading.

Header: A joist or beam that spans two or more studs, accepts overhead loads from floors and roof and distributes the overhead load to the jamb studs supporting the header.

Deflection: The amount of movement of a system, usually greatest at the midpoint, caused by transverse loading.

- L/120: Length (height) of stud, in inches, divided by 120 (short interior wall studs)
- L/240: Length (height) of stud, in inches, divided by 240 (interior wall studs, exterior siding or EIFS)
- L/360: Length (height) of stud, in inches, divided by 360 (exterior stucco)
- L/600: Length (height) of stud, in inches, divided by 600 (exterior brick)
- L/720: Length (height) of stud, in inches, divided by 720 (exterior brick)

Limited deflection: A design criteria which specifies the maximum allowable deflection for a system (L/240, L/360, L/600, etc.).

General table notes.

Unless otherwise noted, properties are computed according to the AISI S100-16 (2020) w/S2-20.

S_xe and M_xa for studs are based on the perforated web properties for the standard ClarkDietrich oval knockout. For tracks, S_xe and M_xa are based on a solid section. I_xe is based on the solid section value for both studs and track.

Overview

Wall stud and floor joist section properties.

ClarkDietrich cold-formed C-studs, produced to AISI S240 standards, for axial load-bearing and curtain wall framing are prepunched with knockouts at regular intervals—specifically designed to allow for rapid installation of pipes, electrical conduit and wall bridging.

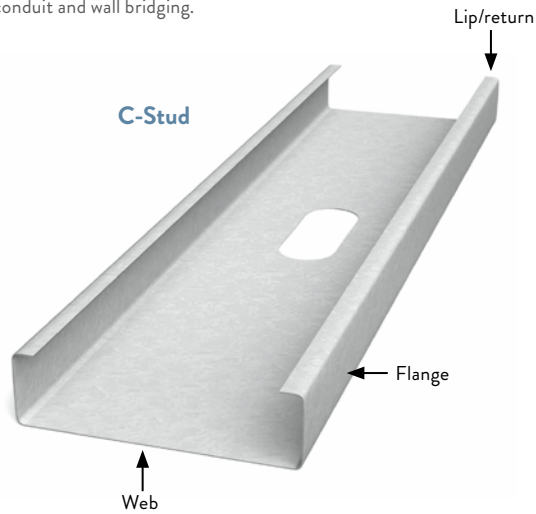

Track section properties.

ClarkDietrich structural track is a U-shaped framing component used as top and bottom runners to secure wall studs. It is produced to AISI S240 standards, and comes in standard 10' lengths. Structural track is also used as end-support closures for joists at exterior or foundation walls, head and sill plates of wall openings and solid blocking.

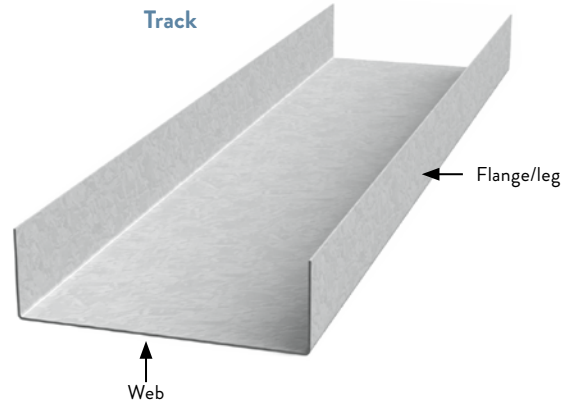

Track is normally ordered in corresponding size and gauge to the wall studs. Longer leg track is used for deflection conditions or to accommodate uneven or inconsistent floor or ceiling conditions. ClarkDietrich also offers custom sizes, lengths and coatings.



PUNCHOUTS / KNOCKOUTS

ClarkDietrich cold-formed C-studs, produced to AISI S240, for axial load-bearing and curtain-wall framing are prepunched with punchouts at regular intervals—specifically designed to allow for rapid installation of pipes, electrical conduit and wall bridging.

East Coast / Central punch spacing:

Center of punchouts are 12" from lead end, then 24" o.c.

West Coast punch spacing:

Center of punchouts are 24" from lead end, then 24" o.c.

Center of tail end punchout not less than 12" from end of stud.

Caution must be exercised when installing studs so knockouts align for bridging. Based on stud length, the distance the knockout falls from the tail end of the stud may not be the same from the lead end. To align punchouts, make sure to use the same end in the same direction consistently.

If lateral bracing is required for head-of-wall deflection track and a punchout is not spaced 12" from the top of stud, use strapping and blocking in lieu of CRC or Spazzer Bar lateral bridging.

If custom punchout patterns are required, contact ClarkDietrich Sales or local plant for requests.

PUNCHOUT SIZES

Standard punchout sizing is 1-1/2" x 4" in members 3-1/2" and wider. Members smaller than 3-1/2" are unpunched unless otherwise specified at time of order. If specified, members will be punched with a 3/4" x 4" knockout.

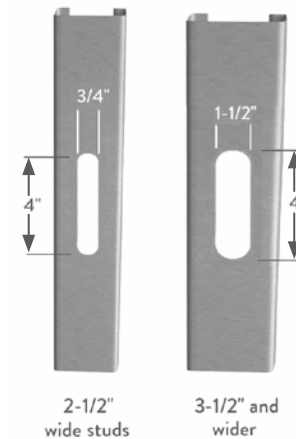

2-1/2" STUD/TRACK PROPERTIES

Member	Design thickness (in)	Yield strength Fy (ksi)	Gross Properties								Effective Properties				Torsional Properties						Lu (in)
			Area (in ²)	Weight (lb/ft)	Ix (in ⁴)	Sx (in ³)	Rx (in)	Iy (in ⁴)	Ry (in)	Ixe (in ⁴)	Sxe (in ³)	Ma (in-k)	Mad (in-k)	Jx1000 (in ⁴)	Cw (in ⁶)	Xo (in)	m (in)	Ro (in)	β		
250S137-33	0.0346	33	0.197	0.671	0.203	0.163	1.02	0.0524	0.515	0.203	0.158	3.11	2.92	0.079	0.076	-1.14	0.677	1.61	0.499	35.6	
250S137-43	0.0451	33	0.255	0.868	0.261	0.208	1.01	0.0665	0.511	0.261	0.205	4.53*	4.06	0.173	0.096	-1.13	0.670	1.60	0.501	35.6	
250S137-54	0.0566	50	0.316	1.07	0.318	0.255	1.00	0.0802	0.504	0.318	0.244	8.22*	7.14	0.337	0.115	-1.11	0.663	1.58	0.504	28.8	
250S137-68	0.0713	50	0.390	1.33	0.386	0.309	0.99	0.0956	0.495	0.386	0.308	10.7*	9.16	0.661	0.138	-1.10	0.653	1.56	0.507	28.9	
250S137-97	0.1017	50	0.533	1.81	0.507	0.406	0.98	0.121	0.476	0.507	0.406	14.8*	12.06	1.84	0.176	-1.06	0.633	1.51	0.513	29.6	
250S162-33	0.0346	33	0.223	0.759	0.235	0.188	1.03	0.0870	0.624	0.235	0.180	3.55	3.42	0.089	0.146	-1.47	0.859	1.90	0.401	44.1	
250S162-43	0.0451	33	0.289	0.984	0.302	0.242	1.02	0.111	0.620	0.302	0.240	5.22*	4.72	0.196	0.184	-1.46	0.852	1.88	0.402	44.2	
250S162-54	0.0566	50	0.358	1.22	0.370	0.296	1.02	0.135	0.613	0.370	0.284	9.42*	8.35	0.383	0.223	-1.44	0.845	1.87	0.404	35.8	
250S162-68	0.0713	50	0.443	1.51	0.450	0.360	1.01	0.162	0.605	0.450	0.357	12.1*	10.72	0.752	0.268	-1.42	0.835	1.85	0.405	36.0	
250S162-97	0.1017	50	0.610	2.07	0.597	0.478	0.99	0.210	0.587	0.597	0.478	16.9*	14.21	2.10	0.346	-1.39	0.815	1.80	0.408	36.9	
250S200-33	0.0346	33	0.258	0.877	0.279	0.223	1.04	0.154	0.773	0.276	0.197	3.90	3.96	0.103	0.302	-1.93	1.11	2.32	0.312	56.0	
250S200-43	0.0451	33	0.334	1.14	0.358	0.287	1.04	0.198	0.769	0.358	0.278	5.49	5.50	0.227	0.382	-1.91	1.10	2.31	0.312	56.1	
250S200-54	0.0566	50	0.415	1.41	0.440	0.352	1.03	0.241	0.763	0.440	0.321	9.61	9.70	0.443	0.464	-1.90	1.09	2.29	0.313	45.5	
250S200-68	0.0713	50	0.515	1.75	0.538	0.430	1.02	0.293	0.755	0.538	0.417	14.0*	12.69	0.872	0.561	-1.88	1.08	2.27	0.313	45.8	
250S200-97	0.1017	50	0.711	2.42	0.719	0.575	1.01	0.386	0.737	0.719	0.575	19.8*	17.13	2.45	0.735	-1.84	1.06	2.22	0.314	46.9	
250S250-43	0.0451	33	0.379	1.29	0.426	0.341	1.06	0.336	0.941	0.426	0.297	5.87	6.04	0.257	0.638	-2.40	1.36	2.79	0.258	66.8	
250S250-54	0.0566	50	0.471	1.60	0.524	0.419	1.05	0.412	0.935	0.521	0.341	10.22	10.59	0.503	0.778	-2.39	1.35	2.77	0.258	54.1	
250S250-68	0.0713	50	0.586	1.99	0.643	0.514	1.05	0.503	0.926	0.643	0.446	13.36	14.01	0.993	0.944	-2.37	1.34	2.75	0.258	54.5	
250S250-97	0.1017	50	0.813	2.77	0.865	0.692	1.03	0.670	0.908	0.865	0.664	22.3*	20.63	2.80	1.25	-2.33	1.32	2.71	0.258	55.9	

250T125-33	0.0346	33	0.173	0.588	0.192	0.145	1.05	0.027	0.397	0.166	0.103	2.03	—	0.069	0.033	-0.760	0.456	1.36	0.687	—
250T125-43	0.0451	33	0.225	0.766	0.250	0.188	1.05	0.035	0.395	0.231	0.147	2.91	—	0.153	0.042	-0.755	0.453	1.36	0.690	—
250T125-54	0.0566	50	0.282	0.961	0.318	0.236	1.06	0.043	0.392	0.297	0.188	5.64	—	0.301	0.054	-0.749	0.449	1.36	0.696	—
250T125-68	0.0713	50	0.355	1.21	0.409	0.297	1.07	0.054	0.389	0.403	0.262	7.85	—	0.602	0.069	-0.740	0.444	1.36	0.704	—
250T125-97	0.1017	50	0.506	1.72	0.604	0.423	1.09	0.074	0.383	0.605	0.423	14.24	—	1.75	0.101	-0.724	0.434	1.37	0.719	—
250T150-33	0.0346	33	0.190	0.647	0.221	0.167	1.08	0.045	0.485	0.180	0.107	2.11	—	0.076	0.054	-0.973	0.573	1.53	0.596	—
250T150-43	0.0451	33	0.248	0.843	0.289	0.217	1.08	0.058	0.483	0.252	0.154	3.03	—	0.168	0.070	-0.968	0.570	1.53	0.599	—
250T150-54	0.0566	50	0.311	1.06	0.368	0.273	1.09	0.072	0.481	0.325	0.197	5.89	—	0.332	0.089	-0.961	0.566	1.53	0.605	—
250T150-68	0.0713	50	0.391	1.33	0.472	0.344	1.10	0.089	0.478	0.445	0.276	8.27	—	0.663	0.114	-0.953	0.561	1.53	0.613	—
250T150-97	0.1017	50	0.557	1.90	0.701	0.491	1.12	0.124	0.472	0.701	0.463	13.87	—	1.92	0.168	-0.935	0.550	1.53	0.629	—
250T200-33	0.0346	33	0.225	0.765	0.280	0.212	1.12	0.097	0.658	0.203	0.112	2.22	—	0.090	0.118	-1.42	0.813	1.92	0.455	—
250T200-43	0.0451	33	0.293	1.00	0.366	0.275	1.12	0.126	0.656	0.288	0.163	3.21	—	0.198	0.153	-1.41	0.810	1.92	0.457	—
250T200-54	0.0566	50	0.367	1.25	0.466	0.346	1.13	0.157	0.654	0.372	0.209	6.25	—	0.392	0.195	-1.41	0.806	1.92	0.462	—
250T200-68	0.0713	50	0.462	1.57	0.600	0.437	1.14	0.196	0.652	0.517	0.296	8.87	—	0.783	0.251	-1.40	0.800	1.92	0.469	—
250T200-97	0.1017	50	0.659	2.24	0.894	0.626	1.16	0.275	0.646	0.856	0.510	15.28	—	2.27	0.374	-1.38	0.789	1.92	0.484	—
250T300-33	0.0346	33	0.294	1.00	0.398	0.301	1.16	0.290	0.993	0.238	0.119	2.36	—	0.117	0.360	-2.35	1.30	2.80	0.298	—
250T300-43	0.0451	33	0.383	1.30	0.521	0.391	1.17	0.376	0.991	0.343	0.174	3.43	—	0.260	0.470	-2.34	1.30	2.80	0.299	—
250T300-54	0.0566	50	0.480	1.63	0.664	0.492	1.18	0.470	0.989	0.443	0.223	6.69	—	0.513	0.599	-2.33	1.29	2.79	0.302	—
250T300-68	0.0713	50	0.605	2.06	0.856	0.623	1.19	0.589	0.987	0.626	0.320	9.57	—	1.03	0.773	-2.32	1.29	2.79	0.307	—
250T300-97	0.1017	50	0.862	2.93	1.279	0.896	1.22	0.830	0.981	1.073	0.563	16.87	—	2.97	1.158	-2.30	1.28	2.78	0.316	—

For additional general notes, see page 6

*Web height-to-thickness ratio exceeds 200. Web stiffeners are required at all support points and concentrated loads.

*Allowable moment includes cold work of forming.

Gross Properties:

- Ix = Moment of Inertia of cross-section about the x-axis.
- Sx = Section Modulus about the x-axis.
- Rx = Radius of Gyration of cross-section about the x-axis.
- Iy = Moment of Inertia of cross-section about the y-axis.
- Ry = Radius of Gyration of cross-section about the y-axis.

Effective Properties:

- Ixe = Effective Moment of Inertia of cross-section about the x-axis.
- Sxe = Effective Section Modulus about the x-axis.
- Ma = Allowable Moment based on local buckling.
- Mad = Allowable Moment based on distortional buckling, assuming Kφ=0.

Torsional and Other Properties:

- J = St. Venant Torsional Constant. The values of J shown in the tables have been factored by 1000.
- Cw = Torsional Warping Constant.
- Xo = Distance from shear center to the centroid along the principal axis.
- m = Distance from shear center to mid-plane of web.

- Ro = Polar Radius of Gyration of cross-section about the shear center.
- Beta = 1-(Xo/Ro)²
- Lu = Critical unbraced length for lateral-torsional buckling. Members are considered fully braced when unbraced length is less than Lu.

Complies with AISI S100-16 (2020) w/S2-20 • IBC 2024

3-1/2" STUD/TRACK PROPERTIES

Member	Design thickness (in)	Yield strength Fy (ksi)	Gross Properties								Effective Properties				Torsional Properties					Lu (in)	
			Area (in ²)	Weight (lb/ft)	Ix (in ⁴)	Sx (in ³)	Rx (in)	Iy (in ⁴)	Ry (in)	Ixe (in ⁴)	Sxe (in ³)	Ma (in-k)	Mad (in-k)	Jx1000 (in ⁴)	Cw (in ⁶)	Xo (in)	m (in)	Ro (in)	β		
3-1/2" Stud	350S137-33	0.0346	33	0.232	0.789	0.442	0.252	1.38	0.0587	0.503	0.442	0.223	4.41	4.55	0.0925	0.153	-1.02	0.621	1.79	0.676	34.8
	350S137-43	0.0451	33	0.300	1.02	0.568	0.324	1.38	0.0746	0.498	0.568	0.307	6.07	6.39	0.204	0.193	-1.00	0.615	1.77	0.679	34.7
	350S137-54	0.0566	50	0.372	1.27	0.696	0.398	1.37	0.0900	0.492	0.696	0.366	10.95	11.43	0.398	0.233	-0.991	0.607	1.76	0.683	28.0
	350S137-68	0.0713	50	0.461	1.57	0.849	0.485	1.36	0.107	0.483	0.849	0.472	14.13	14.53	0.782	0.280	-0.973	0.598	1.74	0.687	27.9
	350S137-97	0.1017	50	0.635	2.16	1.13	0.646	1.33	0.136	0.463	1.13	0.630	22.91	19.34	2.19	0.361	-0.935	0.579	1.69	0.695	28.0
	350S162-33	0.0346	33	0.258	0.877	0.508	0.291	1.40	0.0981	0.617	0.508	0.257	5.09	5.01	0.103	0.277	-1.32	0.796	2.03	0.573	42.7
	350S162-43	0.0451	33	0.334	1.14	0.655	0.374	1.40	0.125	0.612	0.654	0.357	7.05	7.02	0.227	0.350	-1.31	0.789	2.01	0.575	42.6
	350S162-54	0.0566	50	0.415	1.41	0.805	0.460	1.39	0.152	0.606	0.804	0.426	12.74	12.41	0.443	0.426	-1.30	0.782	2.00	0.578	34.5
	350S162-68	0.0713	50	0.515	1.75	0.985	0.563	1.38	0.184	0.597	0.985	0.549	16.44	16.15	0.872	0.514	-1.28	0.772	1.98	0.581	34.5
	350S162-97	0.1017	50	0.711	2.42	1.32	0.755	1.36	0.238	0.579	1.32	0.739	26.20	22.11	2.45	0.672	-1.24	0.752	1.93	0.587	34.7
	350S200-33	0.0346	33	0.292	0.995	0.599	0.342	1.43	0.175	0.773	0.593	0.283	5.59	5.76	0.117	0.541	-1.76	1.04	2.40	0.461	53.7
	350S200-43	0.0451	33	0.379	1.29	0.771	0.441	1.43	0.224	0.768	0.771	0.410	8.09	8.09	0.257	0.687	-1.75	1.03	2.38	0.462	53.7
	350S200-54	0.0566	50	0.471	1.60	0.950	0.543	1.42	0.274	0.762	0.950	0.470	14.07	14.29	0.503	0.838	-1.73	1.02	2.37	0.464	43.5
	350S200-68	0.0713	50	0.586	1.99	1.17	0.667	1.41	0.333	0.754	1.17	0.638	19.11	18.92	0.993	1.02	-1.71	1.01	2.35	0.465	43.5
	350S200-97	0.1017	50	0.813	2.77	1.58	0.901	1.39	0.440	0.736	1.58	0.885	30.53	26.49	2.80	1.35	-1.68	0.994	2.30	0.469	43.9
	350S250-43	0.0451	33	0.424	1.44	0.906	0.518	1.46	0.380	0.946	0.906	0.431	8.53	8.72	0.288	1.15	-2.22	1.29	2.82	0.381	64.3
	350S250-54	0.0566	50	0.528	1.80	1.12	0.639	1.46	0.467	0.940	1.11	0.494	14.78	15.32	0.564	1.41	-2.20	1.28	2.80	0.382	52.1
	350S250-68	0.0713	50	0.657	2.24	1.38	0.787	1.45	0.570	0.931	1.38	0.661	19.78	20.49	1.11	1.72	-2.19	1.27	2.78	0.383	52.2
	350S250-97	0.1017	50	0.915	3.11	1.87	1.07	1.43	0.763	0.913	1.87	1.01	33.90	30.99	3.15	2.29	-2.15	1.25	2.74	0.384	52.7
	3-1/2" Track	350T125-33	0.0346	33	0.207	0.706	0.405	0.222	1.40	0.0299	0.379	0.355	0.165	3.27	—	0.083	0.070	-0.668	0.414	1.59	0.824
350T125-43		0.0451	33	0.270	0.919	0.528	0.288	1.40	0.0385	0.377	0.490	0.233	4.61	—	0.183	0.090	-0.663	0.412	1.59	0.826	—
350T125-54		0.0566	50	0.339	1.15	0.668	0.361	1.40	0.0477	0.375	0.626	0.297	8.90	—	0.362	0.114	-0.658	0.408	1.59	0.830	—
350T125-68		0.0713	50	0.427	1.45	0.851	0.454	1.41	0.0591	0.372	0.839	0.407	12.19	—	0.723	0.144	-0.650	0.403	1.60	0.835	—
350T125-97		0.1017	50	0.608	2.07	1.24	0.645	1.43	0.0815	0.366	1.24	0.645	21.69	—	2.10	0.209	-0.636	0.394	1.61	0.844	—
350T150-33		0.0346	33	0.225	0.765	0.461	0.253	1.43	0.0494	0.469	0.382	0.171	3.39	—	0.090	0.114	-0.866	0.527	1.74	0.752	—
350T150-43		0.0451	33	0.293	1.00	0.601	0.329	1.43	0.0638	0.467	0.531	0.243	4.80	—	0.198	0.148	-0.861	0.525	1.74	0.754	—
350T150-54		0.0566	50	0.367	1.25	0.762	0.412	1.44	0.0793	0.465	0.679	0.310	9.28	—	0.392	0.187	-0.855	0.521	1.74	0.758	—
350T150-68		0.0713	50	0.462	1.57	0.972	0.518	1.45	0.0986	0.462	0.919	0.428	12.81	—	0.783	0.238	-0.847	0.516	1.74	0.763	—
350T150-97		0.1017	50	0.659	2.24	1.42	0.738	1.47	0.137	0.456	1.42	0.701	20.98	—	2.27	0.346	-0.831	0.506	1.75	0.774	—
350T200-33		0.0346	33	0.259	0.883	0.574	0.315	1.49	0.108	0.646	0.428	0.181	3.57	—	0.103	0.249	-1.29	0.761	2.07	0.614	—
350T200-43		0.0451	33	0.338	1.15	0.749	0.409	1.49	0.140	0.645	0.601	0.257	5.09	—	0.229	0.323	-1.28	0.758	2.07	0.616	—
350T200-54		0.0566	50	0.424	1.44	0.949	0.513	1.50	0.175	0.642	0.770	0.329	9.85	—	0.453	0.409	-1.27	0.754	2.07	0.621	—
350T200-68		0.0713	50	0.534	1.82	1.21	0.647	1.51	0.218	0.639	1.05	0.458	13.72	—	0.904	0.522	-1.26	0.749	2.07	0.627	—
350T200-97		0.1017	50	0.761	2.59	1.78	0.924	1.53	0.305	0.633	1.71	0.769	23.02	—	2.62	0.765	-1.25	0.738	2.07	0.638	—
350T300-33		0.0346	33	0.329	1.12	0.799	0.439	1.56	0.324	0.992	0.503	0.190	3.75	—	0.131	0.750	-2.18	1.24	2.86	0.419	—
350T300-43		0.0451	33	0.428	1.46	1.04	0.570	1.56	0.420	0.991	0.710	0.276	5.45	—	0.290	0.976	-2.17	1.24	2.85	0.420	—
350T300-54		0.0566	50	0.537	1.83	1.32	0.716	1.57	0.525	0.989	0.912	0.353	10.58	—	0.573	1.24	-2.16	1.23	2.85	0.424	—
350T300-68		0.0713	50	0.676	2.30	1.70	0.904	1.58	0.657	0.986	1.27	0.496	14.84	—	1.15	1.59	-2.15	1.23	2.85	0.428	—
350T300-97		0.1017	50	0.964	3.28	2.50	1.30	1.61	0.926	0.980	2.11	0.849	25.41	—	3.32	2.34	-2.13	1.22	2.85	0.438	—

For additional general notes, see page 6

*Web-height-to-thickness ratio exceeds 200. Web stiffeners are required at all support points and concentrated loads.

*Allowable moment includes cold work of forming.

Gross Properties:

Ix = Moment of Inertia of cross-section about the x-axis.
 Sx = Section Modulus about the x-axis.
 Rx = Radius of Gyration of cross-section about the x-axis.
 Iy = Moment of Inertia of cross-section about the y-axis.
 Ry = Radius of Gyration of cross-section about the y-axis.

Effective Properties:

Ixe = Effective Moment of Inertia of cross-section about the x-axis.
 Sxe = Effective Section Modulus about the x-axis.
 Ma = Allowable Moment based on local buckling.
 Mad = Allowable Moment based on distortional buckling, assuming $K\phi=0$.

Torsional and Other Properties:

J = St. Venant Torsional Constant. The values of J shown in the tables have been factored by 1000.
 Cw = Torsional Warping Constant.
 Xo = Distance from shear center to the centroid along the principal axis.
 m = Distance from shear center to mid-plane of web.

Ro = Polar Radius of Gyration of cross-section about the shear center.
 Beta = $1-(Xo/Ro)^2$
 Lu = Critical unbraced length for lateral-torsional buckling. Members are considered fully braced when unbraced length is less than Lu.

Complies with AISI S100-16 (2020) w/S2-20 • IBC 2024

3-5/8" STUD/TRACK PROPERTIES

Member	Design thickness (in)	Yield strength Fy (ksi)	Gross Properties							Effective Properties				Torsional Properties					Lu (in)	
			Area (in ²)	Weight (lb/ft)	Ix (in ⁴)	Sx (in ³)	Rx (in)	Iy (in ⁴)	Ry (in)	Ixe (in ⁴)	Sxe (in ³)	Ma (in-k)	Mad (in-k)	Jx1000 (in ⁴)	Cw (in ⁶)	Xo (in)	m (in)	Ro (in)		β
362S137-33	0.0346	33	0.236	0.804	0.479	0.264	1.42	0.0594	0.501	0.479	0.232	4.59	4.48	0.094	0.165	-1.00	0.615	1.81	0.694	34.7
362S137-43	0.0451	33	0.306	1.04	0.616	0.340	1.42	0.0755	0.497	0.616	0.320	6.33	6.30	0.207	0.208	-0.991	0.608	1.80	0.697	34.6
362S137-54	0.0566	50	0.379	1.29	0.756	0.417	1.41	0.0911	0.490	0.756	0.382	11.42	11.15	0.405	0.251	-0.978	0.601	1.79	0.700	27.9
362S137-68	0.0713	50	0.470	1.60	0.923	0.509	1.40	0.109	0.481	0.923	0.493	14.77	14.55	0.797	0.302	-0.959	0.592	1.76	0.704	27.8
362S137-97	0.1017	50	0.648	2.20	1.23	0.678	1.38	0.138	0.461	1.23	0.663	24.11	19.84	2.23	0.390	-0.922	0.573	1.72	0.713	27.8
362S162-33	0.0346	33	0.262	0.892	0.551	0.304	1.45	0.099	0.616	0.551	0.268	5.29	5.22	0.105	0.297	-1.31	0.789	2.05	0.592	42.6
362S162-43	0.0451	33	0.340	1.16	0.710	0.392	1.45	0.127	0.611	0.710	0.372	7.34	7.32	0.230	0.376	-1.30	0.782	2.04	0.594	42.5
362S162-54	0.0566	50	0.422	1.44	0.873	0.482	1.44	0.154	0.605	0.873	0.444	13.28	12.94	0.451	0.457	-1.28	0.774	2.02	0.597	34.4
362S162-68	0.0713	50	0.524	1.78	1.07	0.590	1.43	0.186	0.596	1.07	0.574	17.19	16.94	0.887	0.552	-1.26	0.765	2.00	0.600	34.4
362S162-97	0.1017	50	0.724	2.46	1.44	0.792	1.41	0.241	0.577	1.44	0.776	27.54	23.24	2.50	0.723	-1.23	0.745	1.95	0.606	34.5
362S200-33	0.0346	33	0.297	1.01	0.648	0.358	1.48	0.177	0.772	0.642	0.294	5.81	5.99	0.118	0.577	-1.74	1.03	2.41	0.478	53.6
362S200-43	0.0451	33	0.385	1.31	0.836	0.461	1.47	0.227	0.767	0.836	0.427	8.43	8.43	0.261	0.734	-1.73	1.02	2.40	0.480	53.5
362S200-54	0.0566	50	0.479	1.63	1.03	0.568	1.47	0.277	0.761	1.03	0.490	14.66	14.88	0.511	0.896	-1.71	1.02	2.38	0.482	43.3
362S200-68	0.0713	50	0.595	2.02	1.27	0.698	1.46	0.337	0.753	1.27	0.666	19.95	19.72	1.01	1.09	-1.70	1.01	2.36	0.484	43.3
362S200-97	0.1017	50	0.826	2.81	1.71	0.945	1.44	0.446	0.735	1.71	0.929	32.04	27.81	2.85	1.44	-1.66	0.99	2.32	0.487	43.6
362S250-43	0.0451	33	0.430	1.46	0.980	0.541	1.51	0.385	0.946	0.980	0.449	8.88	9.06	0.292	1.23	-2.20	1.28	2.83	0.396	64.1
362S250-54	0.0566	50	0.535	1.82	1.21	0.668	1.50	0.473	0.940	1.20	0.514	15.40	15.93	0.571	1.51	-2.18	1.27	2.81	0.397	52.0
362S250-68	0.0713	50	0.666	2.27	1.49	0.823	1.50	0.578	0.931	1.49	0.689	20.64	21.32	1.13	1.84	-2.17	1.26	2.79	0.398	52.0
362S250-97	0.1017	50	0.927	3.16	2.03	1.12	1.48	0.773	0.913	2.03	1.06	35.51	32.45	3.20	2.45	-2.13	1.24	2.75	0.401	52.5
362T125-33	0.0346	33	0.212	0.721	0.438	0.232	1.44	0.0301	0.377	0.385	0.174	3.44	—	0.0845	0.076	-0.658	0.410	1.63	0.836	—
362T125-43	0.0451	33	0.276	0.939	0.571	0.302	1.44	0.0388	0.375	0.531	0.245	4.84	—	0.187	0.098	-0.654	0.407	1.62	0.838	—
362T125-54	0.0566	50	0.346	1.18	0.723	0.378	1.45	0.0481	0.373	0.678	0.312	9.34	—	0.369	0.123	-0.648	0.404	1.63	0.841	—
362T125-68	0.0713	50	0.436	1.48	0.921	0.475	1.45	0.0596	0.370	0.908	0.427	12.78	—	0.738	0.156	-0.641	0.399	1.63	0.846	—
362T125-97	0.1017	50	0.621	2.11	1.34	0.675	1.47	0.0822	0.364	1.34	0.675	22.70	—	2.14	0.226	-0.626	0.390	1.64	0.854	—
362T150-33	0.0346	33	0.229	0.780	0.499	0.264	1.48	0.0499	0.467	0.414	0.180	3.56	—	0.091	0.124	-0.854	0.522	1.77	0.766	—
362T150-43	0.0451	33	0.298	1.02	0.650	0.344	1.48	0.0644	0.465	0.575	0.255	5.04	—	0.202	0.160	-0.850	0.519	1.77	0.768	—
362T150-54	0.0566	50	0.374	1.27	0.823	0.431	1.48	0.0801	0.462	0.735	0.325	9.74	—	0.400	0.202	-0.844	0.516	1.77	0.772	—
362T150-68	0.0713	50	0.471	1.60	1.05	0.542	1.49	0.100	0.460	0.993	0.449	13.43	—	0.799	0.257	-0.836	0.511	1.77	0.777	—
362T150-97	0.1017	50	0.672	2.29	1.53	0.771	1.51	0.138	0.453	1.53	0.733	21.94	—	2.32	0.374	-0.820	0.501	1.78	0.787	—
362T200-33	0.0346	33	0.264	0.897	0.619	0.329	1.53	0.110	0.645	0.464	0.190	3.76	—	0.105	0.269	-1.27	0.754	2.09	0.631	—
362T200-43	0.0451	33	0.343	1.17	0.808	0.427	1.53	0.142	0.643	0.650	0.270	5.34	—	0.233	0.350	-1.27	0.752	2.09	0.633	—
362T200-54	0.0566	50	0.431	1.47	1.02	0.536	1.54	0.177	0.640	0.832	0.345	10.34	—	0.460	0.442	-1.26	0.748	2.09	0.638	—
362T200-68	0.0713	50	0.543	1.85	1.31	0.675	1.55	0.221	0.638	1.14	0.480	14.38	—	0.919	0.564	-1.25	0.743	2.09	0.643	—
362T200-97	0.1017	50	0.773	2.63	1.92	0.963	1.57	0.308	0.632	1.84	0.804	24.06	—	2.67	0.825	-1.23	0.732	2.10	0.655	—
362T300-33	0.0346	33	0.333	1.13	0.861	0.457	1.61	0.327	0.992	0.546	0.197	3.89	—	0.133	0.811	-2.16	1.23	2.87	0.434	—
362T300-43	0.0451	33	0.434	1.48	1.12	0.594	1.61	0.425	0.990	0.767	0.290	5.73	—	0.294	1.05	-2.15	1.23	2.86	0.435	—
362T300-54	0.0566	50	0.544	1.85	1.43	0.746	1.62	0.531	0.988	0.985	0.371	11.11	—	0.581	1.34	-2.15	1.23	2.86	0.439	—
362T300-68	0.0713	50	0.685	2.33	1.82	0.941	1.63	0.665	0.985	1.36	0.519	15.55	—	1.16	1.71	-2.14	1.22	2.86	0.443	—
362T300-97	0.1017	50	0.977	3.32	2.68	1.350	1.66	0.937	0.979	2.27	0.887	26.55	—	3.37	2.52	-2.12	1.21	2.86	0.453	—

For additional general notes, see page 6

[†]Web-height-to-thickness ratio exceeds 200. Web stiffeners are required at all support points and concentrated loads.

*Allowable moment includes cold work of forming.

Gross Properties:

Ix = Moment of Inertia of cross-section about the x-axis.
 Sx = Section Modulus about the x-axis.
 Rx = Radius of Gyration of cross-section about the x-axis.
 Iy = Moment of Inertia of cross-section about the y-axis.
 Ry = Radius of Gyration of cross-section about the y-axis.

Effective Properties:

Ixe = Effective Moment of Inertia of cross-section about the x-axis.
 Sxe = Effective Section Modulus about the x-axis.
 Ma = Allowable Moment based on local buckling.
 Mad = Allowable Moment based on distortional buckling, assuming $K\phi=0$.

Torsional and Other Properties:

J = St. Venant Torsional Constant. The values of J shown in the tables have been factored by 1000.
 Cw = Torsional Warping Constant.
 Xo = Distance from shear center to the centroid along the principal axis.
 m = Distance from shear center to mid-plane of web.

Ro = Polar Radius of Gyration of cross-section about the shear center.
 Beta = $1-(Xo/Ro)^2$
 Lu = Critical unbraced length for lateral-torsional buckling. Members are considered fully braced when unbraced length is less than Lu.

Complies with AISI S100-16 (2020) w/S2-20 • IBC 2024

4" STUD/TRACK PROPERTIES

Member	Design thickness (in)	Yield strength Fy (ksi)	Gross Properties								Effective Properties				Torsional Properties					Lu (in)
			Area (in ²)	Weight (lb/ft)	Ix (in ⁴)	Sx (in ³)	Rx (in)	Iy (in ⁴)	Ry (in)	Ixe (in ⁴)	Sxe (in ³)	Ma (in-k)	Mad (in-k)	Jx1000 (in ⁴)	Cw (in ⁶)	Xo (in)	m (in)	Ro (in)	β	
400S137-33	0.0346	33	0.249	0.848	0.603	0.302	1.56	0.0612	0.496	0.603	0.259	5.12	5.01	0.0994	0.204	-0.965	0.597	1.90	0.741	34.5
400S137-43	0.0451	33	0.323	1.10	0.776	0.388	1.55	0.0778	0.491	0.776	0.359	7.09	7.08	0.219	0.257	-0.954	0.591	1.89	0.744	34.3
400S137-54	0.0566	50	0.401	1.36	0.953	0.477	1.54	0.0939	0.484	0.953	0.428	12.82	12.54	0.428	0.311	-0.940	0.583	1.87	0.747	27.7
400S137-68	0.0713	50	0.497	1.69	1.17	0.583	1.53	0.112	0.475	1.17	0.558	16.70	16.65	0.842	0.375	-0.922	0.574	1.85	0.751	27.6
400S137-97	0.1017	50	0.686	2.33	1.56	0.779	1.51	0.142	0.455	1.56	0.765	27.83	22.90	2.36	0.486	-0.885	0.555	1.81	0.760	27.5
400S162-33	0.0346	33	0.275	0.936	0.692	0.346	1.59	0.103	0.611	0.692	0.299	5.91	5.83	0.110	0.363	-1.26	0.768	2.12	0.644	42.3
400S162-43	0.0451	33	0.357	1.21	0.892	0.446	1.58	0.131	0.606	0.892	0.417	8.23	8.21	0.242	0.460	-1.25	0.761	2.11	0.647	42.2
400S162-54	0.0566	50	0.443	1.51	1.10	0.549	1.57	0.159	0.600	1.10	0.498	14.90	14.52	0.473	0.560	-1.24	0.754	2.09	0.649	34.1
400S162-68	0.0713	50	0.550	1.87	1.35	0.673	1.56	0.192	0.591	1.35	0.648	19.41	19.26	0.933	0.677	-1.22	0.745	2.07	0.653	34.0
400S162-97	0.1017	50	0.762	2.59	1.81	0.907	1.54	0.250	0.572	1.81	0.892	31.65	26.72	2.63	0.889	-1.18	0.725	2.03	0.660	34.1
400S200-33	0.0346	33	0.310	1.05	0.812	0.406	1.62	0.183	0.769	0.804	0.329	6.49	6.69	0.124	0.697	-1.69	1.007	2.46	0.530	53.1
400S200-43	0.0451	33	0.402	1.37	1.05	0.524	1.61	0.235	0.764	1.05	0.478	9.45	9.43	0.272	0.886	-1.68	1.000	2.45	0.532	53.0
400S200-54	0.0566	50	0.500	1.70	1.29	0.646	1.61	0.287	0.758	1.29	0.549	16.43	16.66	0.534	1.08	-1.66	0.993	2.43	0.534	42.9
400S200-68	0.0713	50	0.622	2.12	1.59	0.795	1.60	0.349	0.750	1.59	0.751	22.48	22.15	1.05	1.32	-1.64	0.983	2.41	0.536	42.9
400S200-97	0.1017	50	0.864	2.94	2.16	1.08	1.58	0.463	0.732	2.16	1.06	36.69	31.84	2.98	1.75	-1.60	0.963	2.37	0.541	43.1
400S250-43	0.0451	33	0.447	1.52	1.22	0.612	1.66	0.399	0.945	1.22	0.503	9.93	10.09	0.303	1.49	-2.14	1.25	2.86	0.443	63.7
400S250-54	0.0566	50	0.556	1.89	1.51	0.756	1.65	0.490	0.938	1.50	0.576	17.24	17.75	0.594	1.82	-2.12	1.24	2.85	0.444	51.6
400S250-68	0.0713	50	0.693	2.36	1.86	0.932	1.64	0.599	0.929	1.86	0.775	23.20	23.83	1.17	2.23	-2.11	1.23	2.83	0.445	51.6
400S250-97	0.1017	50	0.966	3.29	2.54	1.27	1.62	0.801	0.911	2.54	1.20	40.44	36.66	3.33	2.98	-2.07	1.21	2.78	0.448	51.9
400T125-33	0.0346	33	0.225	0.765	0.549	0.265	1.56	0.0309	0.371	0.484	0.201	3.97	—	0.090	0.095	-0.630	0.396	1.73	0.867	—
400T125-43	0.0451	33	0.293	1.00	0.716	0.344	1.56	0.0398	0.369	0.666	0.282	5.57	—	0.198	0.122	-0.626	0.394	1.72	0.868	—
400T125-54	0.0566	50	0.367	1.25	0.904	0.431	1.57	0.0493	0.366	0.850	0.359	10.74	—	0.392	0.154	-0.621	0.390	1.73	0.871	—
400T125-68	0.0713	50	0.462	1.57	1.15	0.541	1.58	0.0611	0.364	1.13	0.488	14.62	—	0.783	0.194	-0.614	0.386	1.73	0.874	—
400T125-97	0.1017	50	0.659	2.24	1.67	0.768	1.59	0.0842	0.358	1.67	0.768	25.84	—	2.27	0.280	-0.600	0.377	1.74	0.881	—
400T150-33	0.0346	33	0.242	0.824	0.622	0.300	1.60	0.0513	0.460	0.519	0.208	4.12	—	0.097	0.155	-0.821	0.507	1.86	0.805	—
400T150-43	0.0451	33	0.315	1.07	0.811	0.390	1.60	0.0662	0.458	0.719	0.293	5.80	—	0.214	0.200	-0.817	0.504	1.86	0.807	—
400T150-54	0.0566	50	0.396	1.35	1.03	0.489	1.61	0.0822	0.456	0.918	0.374	11.19	—	0.422	0.252	-0.811	0.501	1.86	0.810	—
400T150-68	0.0713	50	0.498	1.69	1.31	0.615	1.62	0.102	0.453	1.24	0.513	15.36	—	0.844	0.320	-0.804	0.496	1.86	0.814	—
400T150-97	0.1017	50	0.710	2.41	1.90	0.874	1.64	0.142	0.447	1.90	0.832	24.92	—	2.45	0.463	-0.788	0.487	1.87	0.823	—
400T200-33	0.0346	33	0.277	0.941	0.768	0.371	1.67	0.113	0.639	0.581	0.220	4.34	—	0.110	0.336	-1.23	0.737	2.17	0.678	—
400T200-43	0.0451	33	0.360	1.23	1.00	0.482	1.67	0.146	0.637	0.811	0.311	6.14	—	0.244	0.436	-1.22	0.734	2.16	0.680	—
400T200-54	0.0566	50	0.452	1.54	1.27	0.604	1.67	0.182	0.635	1.04	0.397	11.88	—	0.483	0.551	-1.22	0.730	2.17	0.684	—
400T200-68	0.0713	50	0.569	1.94	1.62	0.761	1.69	0.227	0.632	1.41	0.549	16.43	—	0.965	0.702	-1.21	0.725	2.17	0.689	—
400T200-97	0.1017	50	0.811	2.76	2.36	1.09	1.71	0.318	0.626	2.27	0.911	27.29	—	2.80	1.02	-1.19	0.715	2.17	0.699	—
400T300-33	0.0346	33	0.346	1.18	1.06	0.512	1.75	0.338	0.989	0.687	0.218	4.32	—	0.138	1.01	-2.10	1.21	2.91	0.478	—
400T300-43	0.0451	33	0.451	1.53	1.38	0.665	1.75	0.439	0.987	0.955	0.334	6.60	—	0.305	1.31	-2.10	1.21	2.91	0.479	—
400T300-54	0.0566	50	0.565	1.92	1.75	0.835	1.76	0.548	0.985	1.22	0.427	12.77	—	0.604	1.66	-2.09	1.21	2.91	0.482	—
400T300-68	0.0713	50	0.712	2.42	2.24	1.05	1.77	0.686	0.982	1.69	0.594	17.78	—	1.21	2.12	-2.08	1.20	2.90	0.487	—
400T300-97	0.1017	50	1.01	3.45	3.28	1.51	1.80	0.967	0.976	2.79	1.01	30.10	—	3.50	3.11	-2.06	1.19	2.90	0.497	—

For additional general notes, see page 6

¹Web-height-to-thickness ratio exceeds 200. Web stiffeners are required at all support points and concentrated loads.

*Allowable moment includes cold work of forming.

Gross Properties:

I_x = Moment of Inertia of cross-section about the x-axis.
 S_x = Section Modulus about the x-axis.
 R_x = Radius of Gyration of cross-section about the x-axis.
 I_y = Moment of Inertia of cross-section about the y-axis.
 R_y = Radius of Gyration of cross-section about the y-axis.

Effective Properties:

I_{xe} = Effective Moment of Inertia of cross-section about the x-axis.
 S_{xe} = Effective Section Modulus about the x-axis.
 M_a = Allowable Moment based on local buckling.
 M_{ad} = Allowable Moment based on distortional buckling, assuming Kφ=0.

Torsional and Other Properties:

J = St. Venant Torsional Constant. The values of J shown in the tables have been factored by 1000.
 C_w = Torsional Warping Constant.
 X_o = Distance from shear center to the centroid along the principal axis.
 m = Distance from shear center to mid-plane of web.

R_o = Polar Radius of Gyration of cross-section about the shear center.
 Beta = 1-(X_o/R_o)?
 L_u = Critical unbraced length for lateral-torsional buckling. Members are considered fully braced when unbraced length is less than L_u.

Complies with AISI S100-16 (2020) w/S2-20 • IBC 2024

5-1/2" STUD/TRACK PROPERTIES

Member	Design thickness (in)	Yield strength Fy (ksi)	Gross Properties								Effective Properties				Torsional Properties						Lu (in)
			Area (in ²)	Weight (lb/ft)	Ix (in ⁴)	Sx (in ³)	Rx (in)	Iy (in ⁴)	Ry (in)	Ixe (in ⁴)	Sxe (in ³)	Ma (in-k)	Mad (in-k)	Jx1000 (in ⁴)	Cw (in ⁶)	Xo (in)	m (in)	Ro (in)	β		
550S137-33	0.0346	33	0.301	1.02	1.28	0.467	2.06	0.0670	0.472	1.28	0.453	9.82	7.49	0.120	0.411	-0.841	0.536	2.28	0.864	33.7	
550S137-43	0.0451	33	0.391	1.33	1.66	0.602	2.06	0.0852	0.467	1.66	0.602	13.29	10.76	0.265	0.520	-0.830	0.530	2.27	0.866	33.5	
550S137-54	0.0566	50	0.486	1.65	2.04	0.742	2.05	0.103	0.460	2.04	0.722	24.33	19.31	0.519	0.632	-0.817	0.523	2.25	0.868	27.0	
550S137-68	0.0713	50	0.604	2.05	2.50	0.911	2.04	0.123	0.451	2.50	0.910	31.48	26.11	1.02	0.764	-0.801	0.514	2.23	0.872	26.8	
550S137-97	0.1017	50	0.838	2.85	3.38	1.23	2.01	0.156	0.431	3.38	1.23	44.73	36.81	2.89	0.997	-0.766	0.497	2.19	0.878	26.4	
550S162-33	0.0346	33	0.327	1.11	1.46	0.530	2.11	0.113	0.589	1.46	0.512	10.11	8.32	0.130	0.713	-1.11	0.697	2.46	0.795	41.4	
550S162-43	0.0451	33	0.424	1.44	1.88	0.685	2.11	0.145	0.584	1.88	0.681	14.8*	11.85	0.288	0.905	-1.10	0.691	2.45	0.797	41.2	
550S162-54	0.0566	50	0.528	1.80	2.32	0.845	2.10	0.176	0.577	2.32	0.811	26.9*	21.01	0.564	1.10	-1.09	0.684	2.43	0.800	33.2	
550S162-68	0.0713	50	0.657	2.24	2.86	1.04	2.09	0.212	0.569	2.86	1.03	34.9*	28.24	1.11	1.34	-1.07	0.675	2.41	0.803	33.1	
550S162-97	0.1017	50	0.915	3.11	3.89	1.41	2.06	0.276	0.550	3.89	1.41	50.1*	42.01	3.15	1.77	-1.04	0.656	2.37	0.809	32.8	
550S200-33	0.0346	33	0.362	1.23	1.69	0.616	2.16	0.204	0.751	1.68	0.559	11.05	9.51	0.144	1.33	-1.51	0.925	2.74	0.698	51.9	
550S200-43	0.0451	33	0.469	1.60	2.19	0.796	2.16	0.261	0.746	2.19	0.776	15.34	13.54	0.318	1.69	-1.50	0.918	2.73	0.700	51.7	
550S200-54	0.0566	50	0.585	1.99	2.71	0.984	2.15	0.320	0.739	2.71	0.901	26.99	23.95	0.624	2.07	-1.48	0.911	2.72	0.702	41.8	
550S200-68	0.0713	50	0.729	2.48	3.34	1.22	2.14	0.389	0.731	3.34	1.19	39.44	32.22	1.23	2.53	-1.46	0.902	2.70	0.705	41.7	
550S200-97	0.1017	50	1.02	3.46	4.56	1.66	2.12	0.516	0.713	4.56	1.66	57.3*	49.20	3.50	3.38	-1.43	0.882	2.65	0.710	41.5	
550S250-43	0.0451	33	0.515	1.75	2.52	0.918	2.22	0.445	0.930	2.52	0.817	16.15	14.31	0.349	2.84	-1.93	1.16	3.08	0.607	62.6	
550S250-54	0.0566	50	0.641	2.18	3.13	1.14	2.21	0.547	0.923	3.08	0.950	28.44	25.22	0.685	3.49	-1.92	1.16	3.07	0.609	50.7	
550S250-68	0.0713	50	0.800	2.72	3.87	1.41	2.20	0.669	0.914	3.86	1.23	36.91	34.16	1.36	4.27	-1.90	1.15	3.05	0.611	50.6	
550S250-97	0.1017	50	1.12	3.80	5.31	1.93	2.18	0.897	0.896	5.31	1.84	61.8*	53.51	3.85	5.76	-1.86	1.13	3.00	0.616	50.5	
550T125-33	0.0346	33	0.277	0.941	1.16	0.411	2.05	0.0332	0.346	1.03	0.270	5.33	—	0.110	0.195	-0.541	0.350	2.15	0.936	—	
550T125-43	0.0451	33	0.360	1.23	1.51	0.534	2.05	0.0428	0.344	1.43	0.417	8.23	—	0.244	0.252	-0.537	0.348	2.14	0.937	—	
550T125-54	0.0566	50	0.452	1.54	1.90	0.668	2.05	0.0530	0.342	1.81	0.535	16.01	—	0.483	0.315	-0.532	0.345	2.15	0.939	—	
550T125-68	0.0713	50	0.569	1.94	2.41	0.839	2.06	0.0656	0.340	2.38	0.769	23.02	—	0.965	0.397	-0.526	0.341	2.15	0.940	—	
550T125-97	0.1017	50	0.811	2.76	3.48	1.19	2.07	0.0904	0.334	3.48	1.19	40.01	—	2.80	0.564	-0.514	0.333	2.16	0.943	—	
550T150-33	0.0346	33	0.294	1.00	1.30	0.459	2.10	0.0555	0.434	1.12	0.310	6.12	—	0.117	0.320	-0.714	0.455	2.26	0.900	—	
550T150-43	0.0451	33	0.383	1.30	1.69	0.596	2.10	0.0716	0.432	1.52	0.468	9.25	—	0.260	0.414	-0.709	0.452	2.26	0.901	—	
550T150-54	0.0566	50	0.480	1.63	2.13	0.747	2.10	0.0889	0.430	1.93	0.595	17.81	—	0.513	0.519	-0.704	0.449	2.26	0.903	—	
550T150-68	0.0713	50	0.605	2.06	2.70	0.939	2.11	0.111	0.427	2.57	0.804	24.07	—	1.03	0.655	-0.698	0.445	2.27	0.905	—	
550T150-97	0.1017	50	0.862	2.93	3.91	1.33	2.13	0.153	0.421	3.90	1.28	38.28	—	2.97	0.937	-0.684	0.436	2.27	0.909	—	
550T200-33	0.0346	33	0.329	1.12	1.57	0.555	2.18	0.123	0.613	1.25	0.307	6.06	—	0.131	0.694	-1.09	0.674	2.52	0.813	—	
550T200-43	0.0451	33	0.428	1.46	2.04	0.722	2.19	0.160	0.611	1.69	0.495	9.79	—	0.290	0.900	-1.08	0.671	2.51	0.814	—	
550T200-54	0.0566	50	0.537	1.83	2.58	0.905	2.19	0.199	0.609	2.15	0.630	18.86	—	0.573	1.13	-1.08	0.668	2.52	0.817	—	
550T200-68	0.0713	50	0.676	2.30	3.27	1.14	2.20	0.248	0.606	2.89	0.857	25.67	—	1.15	1.43	-1.07	0.663	2.52	0.820	—	
550T200-97	0.1017	50	0.964	3.28	4.75	1.62	2.22	0.347	0.600	4.57	1.39	41.64	—	3.32	2.07	-1.05	0.653	2.53	0.826	—	
550T300-33	0.0346	33	0.398	1.35	2.11	0.748	2.30	0.374	0.969	1.46	0.303	5.98	—	0.159	2.07	-1.91	1.14	3.15	0.632	—	
550T300-43	0.0451	33	0.518	1.76	2.76	0.973	2.31	0.485	0.967	1.99	0.510	10.08	—	0.351	2.69	-1.90	1.13	3.14	0.633	—	
550T300-54	0.0566	50	0.650	2.21	3.48	1.22	2.31	0.606	0.965	2.53	0.663	19.84	—	0.694	3.39	-1.90	1.13	3.14	0.636	—	
550T300-68	0.0713	50	0.819	2.79	4.42	1.54	2.32	0.758	0.962	3.42	0.929	27.80	—	1.39	4.31	-1.89	1.12	3.15	0.640	—	
550T300-97	0.1017	50	1.167	3.97	6.43	2.20	2.35	1.07	0.956	5.52	1.53	45.84	—	4.02	6.25	-1.87	1.11	3.15	0.647	—	

For additional general notes, see page 6

*Web height-to-thickness ratio exceeds 200. Web stiffeners are required at all support points and concentrated loads.

*Allowable moment includes cold work of forming.

Gross Properties:

- Ix = Moment of Inertia of cross-section about the x-axis.
- Sx = Section Modulus about the x-axis.
- Rx = Radius of Gyration of cross-section about the x-axis.
- Iy = Moment of Inertia of cross-section about the y-axis.
- Ry = Radius of Gyration of cross-section about the y-axis.

Effective Properties:

- Ixe = Effective Moment of Inertia of cross-section about the x-axis.
- Sxe = Effective Section Modulus about the x-axis.
- Ma = Allowable Moment based on local buckling.
- Mad = Allowable Moment based on distortional buckling, assuming Kφ=0.

Torsional and Other Properties:

- J = St. Venant Torsional Constant. The values of J shown in the tables have been factored by 1000.
- Cw = Torsional Warping Constant.
- Xo = Distance from shear center to the centroid along the principal axis.
- m = Distance from shear center to mid-plane of web.

- Ro = Polar Radius of Gyration of cross-section about the shear center.
- Beta = 1-(Xo/Ro)²
- Lu = Critical unbraced length for lateral-torsional buckling. Members are considered fully braced when unbraced length is less than Lu.

Complies with AISI S100-16 (2020) w/S2-20 • IBC 2024

6" STUD/TRACK PROPERTIES

Member	Design thickness (in)	Yield strength Fy (ksi)	Gross Properties								Effective Properties				Torsional Properties					Lu (in)
			Area (in ²)	Weight (lb/ft)	Ix (in ⁴)	Sx (in ³)	Rx (in)	Iy (in ⁴)	Ry (in)	Ixe (in ⁴)	Sxe (in ³)	Ma (in-k)	Mad (in-k)	Jx1000 (in ⁴)	Cw (in ⁶)	Xo (in)	m (in)	Ro (in)	β	
600S137-33	0.0346	33	0.318	1.08	1.58	0.528	2.23	0.0685	0.464	1.55	0.455	8.98	7.82	0.127	0.500	-0.807	0.519	2.42	0.889	33.5
600S137-43	0.0451	33	0.413	1.41	2.04	0.681	2.22	0.0871	0.459	2.04	0.645	12.74	11.26	0.280	0.633	-0.796	0.513	2.41	0.890	33.3
600S137-54	0.0566	50	0.514	1.75	2.52	0.839	2.21	0.105	0.452	2.52	0.777	23.26	20.04	0.549	0.769	-0.784	0.506	2.39	0.893	26.8
600S137-68	0.0713	50	0.640	2.18	3.10	1.03	2.20	0.125	0.443	3.09	1.03	30.85	27.21	1.08	0.930	-0.768	0.497	2.37	0.895	26.5
600S137-97	0.1017	50	0.889	3.03	4.19	1.40	2.17	0.159	0.423	4.19	1.40	50.8*	41.53	3.07	1.22	-0.734	0.480	2.33	0.901	26.1
600S162-33	0.0346	33	0.344	1.17	1.79	0.598	2.28	0.116	0.581	1.79	0.577	11.41	9.13	0.137	0.861	-1.07	0.677	2.59	0.828	41.1
600S162-43	0.0451	33	0.447	1.52	2.32	0.772	2.28	0.148	0.576	2.32	0.767	16.7*	13.06	0.303	1.10	-1.06	0.670	2.58	0.830	40.9
600S162-54	0.0566	50	0.556	1.89	2.86	0.954	2.27	0.180	0.570	2.86	0.916	30.3*	23.17	0.594	1.34	-1.05	0.663	2.56	0.833	33.0
600S162-68	0.0713	50	0.693	2.36	3.53	1.18	2.26	0.218	0.561	3.52	1.16	39.5*	31.28	1.17	1.63	-1.03	0.655	2.54	0.835	32.8
600S162-97	0.1017	50	0.966	3.29	4.80	1.60	2.23	0.283	0.542	4.80	1.60	56.7*	47.61	3.33	2.15	-1.00	0.636	2.50	0.841	32.5
600S200-33	0.0346	33	0.379	1.29	2.08	0.692	2.34	0.209	0.743	2.06	0.621	12.28	10.46	0.151	1.59	-1.46	0.901	2.86	0.740	51.6
600S200-43	0.0451	33	0.492	1.67	2.68	0.894	2.34	0.268	0.739	2.68	0.873	17.24	14.93	0.334	2.03	-1.45	0.894	2.84	0.742	51.4
600S200-54	0.0566	50	0.613	2.09	3.32	1.11	2.33	0.329	0.732	3.32	1.02	30.40	26.42	0.655	2.49	-1.43	0.887	2.83	0.744	41.6
600S200-68	0.0713	50	0.764	2.60	4.10	1.37	2.32	0.400	0.723	4.10	1.32	43.7*	35.65	1.30	3.05	-1.41	0.878	2.81	0.746	41.4
600S200-97	0.1017	50	1.07	3.63	5.61	1.87	2.29	0.530	0.705	5.61	1.87	64.5*	55.28	3.68	4.08	-1.38	0.859	2.77	0.752	41.2
600S250-43	0.0451	33	0.537	1.83	3.08	1.03	2.40	0.458	0.923	3.08	0.918	18.14	15.74	0.364	3.41	-1.87	1.14	3.18	0.652	62.4
600S250-54	0.0566	50	0.670	2.28	3.82	1.27	2.39	0.562	0.917	3.77	1.07	32.00	27.75	0.715	4.19	-1.86	1.13	3.16	0.654	50.5
600S250-68	0.0713	50	0.836	2.84	4.73	1.58	2.38	0.688	0.908	4.72	1.39	41.50	37.69	1.42	5.15	-1.84	1.12	3.14	0.657	50.4
600S250-97	0.1017	50	1.17	3.98	6.50	2.17	2.36	0.923	0.889	6.50	2.06	69.4*	59.34	4.03	6.95	-1.80	1.10	3.10	0.661	50.2
600S300-54	0.0566	50	0.726	2.47	4.32	1.44	2.44	0.875	1.10	4.01	1.11	33.13	28.68	0.775	6.45	-2.30	1.37	3.53	0.575	59.1
600S300-68	0.0713	50	0.907	3.09	5.35	1.78	2.43	1.08	1.09	5.22	1.45	43.30	39.15	1.54	7.94	-2.28	1.36	3.51	0.577	58.9
600S300-97	0.1017	50	1.27	4.32	7.38	2.46	2.41	1.45	1.07	7.28	2.25	67.29	62.34	4.38	10.78	-2.24	1.34	3.46	0.581	58.8
600T125-33	0.0346	33	0.294	1.00	1.43	0.465	2.20	0.0338	0.339	1.26	0.297	5.87	—	0.117	0.238	-0.516	0.337	2.29	0.949	—
600T125-43	0.0451	33	0.383	1.30	1.86	0.604	2.20	0.0435	0.337	1.77	0.461	9.11	—	0.260	0.307	-0.513	0.335	2.29	0.950	—
600T125-54	0.0566	50	0.480	1.63	2.34	0.757	2.21	0.0539	0.335	2.24	0.592	17.74	—	0.513	0.384	-0.508	0.332	2.29	0.951	—
600T125-68	0.0713	50	0.605	2.06	2.97	0.951	2.22	0.0668	0.332	2.93	0.858	25.69	—	1.03	0.483	-0.503	0.329	2.30	0.952	—
600T125-97	0.1017	50	0.862	2.93	4.28	1.35	2.23	0.0919	0.327	4.28	1.347	45.31	—	2.97	0.685	-0.491	0.321	2.31	0.955	—
600T150-33	0.0346	33	0.311	1.06	1.59	0.52	2.26	0.057	0.426	1.33	0.303	5.99	—	0.124	0.390	-0.684	0.439	2.40	0.919	—
600T150-43	0.0451	33	0.405	1.38	2.07	0.67	2.26	0.073	0.424	1.89	0.474	9.36	—	0.275	0.504	-0.680	0.437	2.40	0.920	—
600T150-54	0.0566	50	0.509	1.73	2.61	0.84	2.27	0.091	0.422	2.40	0.609	18.24	—	0.543	0.632	-0.675	0.434	2.40	0.921	—
600T150-68	0.0713	50	0.641	2.18	3.31	1.06	2.27	0.113	0.419	3.16	0.891	26.68	—	1.09	0.797	-0.669	0.430	2.41	0.923	—
600T150-97	0.1017	50	0.913	3.11	4.78	1.50	2.29	0.156	0.414	4.78	1.444	43.24	—	3.15	1.14	-0.656	0.421	2.42	0.926	—
600T200-33	0.0346	33	0.346	1.18	1.91	0.623	2.35	0.126	0.604	1.54	0.333	6.59	—	0.138	0.847	-1.05	0.655	2.64	0.843	—
600T200-43	0.0451	33	0.451	1.53	2.49	0.810	2.35	0.163	0.602	2.08	0.565	11.16	—	0.305	1.10	-1.04	0.652	2.64	0.844	—
600T200-54	0.0566	50	0.565	1.92	3.15	1.01	2.36	0.203	0.600	2.64	0.717	21.48	—	0.604	1.38	-1.04	0.649	2.65	0.846	—
600T200-68	0.0713	50	0.712	2.42	3.99	1.28	2.37	0.254	0.597	3.54	0.973	29.12	—	1.21	1.75	-1.03	0.644	2.65	0.849	—
600T200-97	0.1017	50	1.01	3.45	5.77	1.82	2.39	0.355	0.591	5.56	1.57	46.95	—	3.50	2.51	-1.02	0.635	2.66	0.854	—
600T300-33	0.0346	33	0.415	1.41	2.56	0.83	2.48	0.384	0.961	1.81	0.331	6.54	—	0.166	2.52	-1.85	1.11	3.24	0.674	—
600T300-43	0.0451	33	0.541	1.84	3.34	1.08	2.48	0.498	0.960	2.45	0.556	10.98	—	0.367	3.28	-1.85	1.11	3.24	0.675	—
600T300-54	0.0566	50	0.679	2.31	4.21	1.36	2.49	0.622	0.957	3.11	0.722	21.61	—	0.725	4.13	-1.84	1.11	3.24	0.677	—
600T300-68	0.0713	50	0.854	2.91	5.35	1.71	2.50	0.778	0.954	4.16	1.05	31.53	—	1.45	5.24	-1.83	1.10	3.25	0.681	—
600T300-97	0.1017	50	1.22	4.15	7.76	2.44	2.52	1.10	0.948	6.68	1.72	51.63	—	4.20	7.58	-1.82	1.09	3.25	0.688	—

For additional general notes, see page 6

¹Web-height-to-thickness ratio exceeds 200. Web stiffeners are required at all support points and concentrated loads.

*Allowable moment includes cold work of forming.

Gross Properties:

Ix = Moment of Inertia of cross-section about the x-axis.
 Sx = Section Modulus about the x-axis.
 Rx = Radius of Gyration of cross-section about the x-axis.
 Iy = Moment of Inertia of cross-section about the y-axis.
 Ry = Radius of Gyration of cross-section about the y-axis.

Effective Properties:

Ixe = Effective Moment of Inertia of cross-section about the x-axis.
 Sxe = Effective Section Modulus about the x-axis.
 Ma = Allowable Moment based on local buckling.
 Mad = Allowable Moment based on distortional buckling, assuming Kφ=0.

Torsional and Other Properties:

J = St. Venant Torsional Constant. The values of J shown in the tables have been factored by 1000.
 Cw = Torsional Warping Constant.
 Xo = Distance from shear center to the centroid along the principal axis.
 m = Distance from shear center to mid-plane of web.

Ro = Polar Radius of Gyration of cross-section about the shear center.
 Beta = 1-(Xo/Ro)²
 Lu = Critical unbraced length for lateral-torsional buckling. Members are considered fully braced when unbraced length is less than Lu.

Complies with AISI S100-16 (2020) w/S2-20 • IBC 2024

8" STUD/TRACK PROPERTIES

Member	Design thickness (in)	Yield strength Fy (ksi)	Gross Properties								Effective Properties				Torsional Properties						Lu (in)
			Area (in ²)	Weight (lb/ft)	Ix (in ⁴)	Sx (in ³)	Rx (in)	Iy (in ⁴)	Ry (in)	Ixe (in ⁴)	Sxe (in ³)	Ma (in-k)	Mad (in-k)	Jx1000 (in ⁴)	Cw (in ⁶)	Xo (in)	m (in)	Ro (in)	β		
800S137-33'	0.0346	33	0.388	1.32	3.20	0.80	2.87	0.073	0.435	3.00	0.622	12.30	10.29	0.155	0.957	-0.696	0.460	2.99	0.946	32.5	
800S137-43	0.0451	33	0.503	1.71	4.14	1.03	2.87	0.093	0.430	4.00	0.896	17.70	15.10	0.341	1.21	-0.687	0.454	2.98	0.947	32.2	
800S137-54	0.0566	50	0.627	2.13	5.11	1.28	2.86	0.112	0.423	4.97	1.08	32.43	27.02	0.670	1.48	-0.676	0.448	2.96	0.948	25.9	
800S137-68	0.0713	50	0.782	2.66	6.31	1.58	2.84	0.134	0.414	6.29	1.47	43.97	37.40	1.33	1.79	-0.661	0.440	2.94	0.950	25.6	
800S137-97	0.1017	50	1.09	3.72	8.60	2.15	2.81	0.170	0.394	8.60	2.15	64.36	60.29	3.77	2.35	-0.630	0.423	2.90	0.953	25.1	
800S162-33'	0.0346	33	0.413	1.41	3.58	0.896	2.94	0.125	0.550	3.38	0.710	14.03	12.22	0.165	1.63	-0.936	0.607	3.14	0.911	40.1	
800S162-43	0.0451	33	0.537	1.83	4.63	1.16	2.94	0.160	0.546	4.50	1.02	20.14	17.72	0.364	2.08	-0.926	0.601	3.13	0.912	39.8	
800S162-54	0.0566	50	0.670	2.28	5.74	1.43	2.93	0.194	0.539	5.60	1.23	36.79	31.52	0.715	2.54	-0.914	0.594	3.11	0.914	32.1	
800S162-68	0.0713	50	0.836	2.84	7.09	1.77	2.91	0.235	0.530	7.07	1.66	49.81	43.23	1.42	3.09	-0.899	0.586	3.09	0.916	31.9	
800S162-97	0.1017	50	1.17	3.98	9.72	2.43	2.88	0.305	0.511	9.71	2.43	72.71	68.90	4.03	4.11	-0.866	0.568	3.05	0.920	31.4	
800S200-33'	0.0346	33	0.448	1.52	4.10	1.02	3.02	0.227	0.712	4.10	0.816	16.12	14.15	0.179	2.97	-1.29	0.817	3.36	0.853	50.6	
800S200-43	0.0451	33	0.582	1.98	5.30	1.33	3.02	0.292	0.708	5.30	1.29	25.54	20.41	0.395	3.80	-1.28	0.811	3.35	0.855	50.3	
800S200-54	0.0566	50	0.726	2.47	6.57	1.64	3.01	0.357	0.701	6.57	1.50	44.87	36.18	0.775	4.66	-1.26	0.804	3.34	0.856	40.7	
800S200-68	0.0713	50	0.907	3.09	8.14	2.04	3.00	0.435	0.692	8.14	1.96	65.2*	49.39	1.54	5.71	-1.25	0.796	3.32	0.859	40.4	
800S200-97	0.1017	50	1.27	4.32	11.2	2.80	2.97	0.577	0.674	11.20	2.80	96.6*	78.36	4.38	7.68	-1.21	0.777	3.28	0.863	40.0	
800S250-43	0.0451	33	0.627	2.13	6.02	1.50	3.10	0.500	0.893	6.02	1.31	25.96	21.47	0.425	6.37	-1.67	1.04	3.63	0.787	61.5	
800S250-54	0.0566	50	0.783	2.66	7.47	1.87	3.09	0.614	0.886	7.38	1.53	45.66	37.93	0.836	7.85	-1.66	1.04	3.62	0.789	49.8	
800S250-68	0.0713	50	0.978	3.33	9.26	2.32	3.08	0.752	0.877	9.24	2.06	61.65	52.00	1.66	9.65	-1.64	1.03	3.60	0.791	49.6	
800S250-97	0.1017	50	1.37	4.67	12.8	3.20	3.05	1.01	0.858	12.8	3.05	102.7*	83.33	4.73	13.1	-1.61	1.01	3.56	0.796	49.2	
800S300-54	0.0566	50	0.839	2.86	8.36	2.09	3.16	0.959	1.07	7.86	1.54	45.97	39.05	0.896	12.1	-2.07	1.27	3.92	0.721	58.6	
800S300-68	0.0713	50	1.05	3.57	10.4	2.60	3.15	1.18	1.06	10.1	2.14	64.22	53.72	1.78	14.9	-2.05	1.26	3.90	0.723	58.4	
800S300-97	0.1017	50	1.47	5.02	14.4	3.59	3.12	1.60	1.04	14.2	3.30	98.93	86.82	5.08	20.3	-2.02	1.24	3.86	0.727	58.1	
800T125-33'	0.0346	33	0.363	1.24	2.90	0.711	2.82	0.0356	0.313	2.44	0.407	8.03	—	0.145	0.456	-0.439	0.294	2.88	0.977	—	
800T125-43	0.0451	33	0.473	1.61	3.77	0.925	2.82	0.0458	0.311	3.48	0.640	12.65	—	0.321	0.589	-0.436	0.292	2.87	0.977	—	
800T125-54	0.0566	50	0.594	2.02	4.75	1.16	2.83	0.0568	0.309	4.43	0.824	24.66	—	0.634	0.735	-0.432	0.289	2.88	0.977	—	
800T125-68	0.0713	50	0.748	2.54	6.00	1.45	2.83	0.0703	0.307	5.96	1.22	36.40	—	1.27	0.920	-0.427	0.286	2.88	0.978	—	
800T125-97	0.1017	50	1.07	3.63	8.62	2.06	2.84	0.0967	0.301	8.61	2.06	69.34	—	3.67	1.30	-0.417	0.279	2.89	0.979	—	
800T150-33'	0.0346	33	0.380	1.29	3.18	0.781	2.89	0.0600	0.397	2.57	0.414	8.18	—	0.152	0.751	-0.588	0.388	2.98	0.961	—	
800T150-43	0.0451	33	0.496	1.69	4.15	1.02	2.89	0.0774	0.395	3.69	0.655	12.95	—	0.336	0.972	-0.584	0.386	2.98	0.961	—	
800T150-54	0.0566	50	0.622	2.12	5.22	1.27	2.90	0.0961	0.393	4.69	0.844	25.27	—	0.664	1.22	-0.580	0.383	2.98	0.962	—	
800T150-68	0.0713	50	0.783	2.67	6.60	1.60	2.90	0.119	0.390	6.36	1.26	37.58	—	1.33	1.53	-0.575	0.379	2.98	0.963	—	
800T150-97	0.1017	50	1.12	3.80	9.48	2.27	2.91	0.165	0.385	9.48	2.19	65.62	—	3.85	2.16	-0.564	0.372	2.99	0.965	—	
800T200-33'	0.0346	33	0.415	1.41	3.75	0.921	3.01	0.135	0.571	2.79	0.424	8.37	—	0.166	1.64	-0.917	0.589	3.19	0.918	—	
800T200-43	0.0451	33	0.541	1.84	4.89	1.20	3.01	0.175	0.569	4.04	0.676	13.35	—	0.367	2.12	-0.913	0.587	3.19	0.918	—	
800T200-54	0.0566	50	0.679	2.31	6.15	1.50	3.01	0.218	0.567	5.15	0.872	26.09	—	0.725	2.66	-0.908	0.584	3.20	0.919	—	
800T200-68	0.0713	50	0.854	2.91	7.79	1.89	3.02	0.272	0.564	7.05	1.31	39.22	—	1.45	3.36	-0.902	0.580	3.20	0.921	—	
800T200-97	0.1017	50	1.22	4.15	11.2	2.68	3.03	0.379	0.558	10.8	2.35	70.28	—	4.20	4.79	-0.889	0.571	3.21	0.923	—	
800T300-33'	0.0346	33	0.484	1.65	4.89	1.20	3.18	0.416	0.927	3.46	0.443	8.76	—	0.193	4.87	-1.66	1.03	3.70	0.799	—	
800T300-43	0.0451	33	0.631	2.15	6.37	1.56	3.18	0.540	0.925	4.92	0.737	14.56	—	0.428	6.33	-1.66	1.02	3.70	0.800	—	
800T300-54	0.0566	50	0.792	2.69	8.03	1.96	3.18	0.674	0.923	6.24	0.956	28.62	—	0.845	7.96	-1.65	1.02	3.70	0.801	—	
800T300-68	0.0713	50	0.997	3.39	10.17	2.47	3.19	0.844	0.920	8.16	1.55	46.36	—	1.69	10.1	-1.64	1.02	3.71	0.803	—	
800T300-97	0.1017	50	1.42	4.84	14.7	3.51	3.21	1.19	0.914	12.8	2.59	77.44	—	4.90	14.5	-1.63	1.01	3.72	0.808	—	

For additional general notes, see page 6

¹Web-height-to-thickness ratio exceeds 200. Web stiffeners are required at all support points and concentrated loads.

*Allowable moment includes cold work of forming.

Gross Properties:

- Ix = Moment of Inertia of cross-section about the x-axis.
- Sx = Section Modulus about the x-axis.
- Rx = Radius of Gyration of cross-section about the x-axis.
- Iy = Moment of Inertia of cross-section about the y-axis.
- Ry = Radius of Gyration of cross-section about the y-axis.

Effective Properties:

- Ixe = Effective Moment of Inertia of cross-section about the x-axis.
- Sxe = Effective Section Modulus about the x-axis.
- Ma = Allowable Moment based on local buckling.
- Mad = Allowable Moment based on distortional buckling, assuming Kφ=0.

Torsional and Other Properties:

- J = St. Venant Torsional Constant. The values of J shown in the tables have been factored by 1000.
- Cw = Torsional Warping Constant.
- Xo = Distance from shear center to the centroid along the principal axis.
- m = Distance from shear center to mid-plane of web.

- Ro = Polar Radius of Gyration of cross-section about the shear center.
- Beta = 1-(Xo/Ro)?
- Lu = Critical unbraced length for lateral-torsional buckling. Members are considered fully braced when unbraced length is less than Lu.

Complies with AISI S100-16 (2020) w/S20-0 • IBC 2024

10" STUD/TRACK PROPERTIES

Member	Design thickness (in)	Yield strength Fy (ksi)	Gross Properties								Effective Properties				Torsional Properties						Lu (in)
			Area (in ²)	Weight (lb/ft)	Ix (in ⁴)	Sx (in ³)	Rx (in)	Iy (in ⁴)	Ry (in)	Ixe (in ⁴)	Sxe (in ³)	Ma (in-k)	Mad (in-k)	Jx1000 (in ⁴)	Cw (in ⁶)	Xo (in)	m (in)	Ro (in)	β		
1000S162-43 ¹	0.0451	33	0.627	2.13	8.03	1.61	3.58	0.168	0.518	7.52	1.30	25.74	21.81	0.425	3.43	-0.823	0.545	3.71	0.951	38.8	
1000S162-54	0.0566	50	0.783	2.66	9.95	1.99	3.57	0.204	0.511	9.39	1.57	47.07	38.94	0.836	4.20	-0.812	0.538	3.69	0.952	31.3	
1000S162-68	0.0713	50	0.978	3.33	12.3	2.47	3.55	0.247	0.502	12.0	2.15	64.51	54.18	1.66	5.12	-0.798	0.531	3.67	0.953	31.0	
1000S162-97	0.1017	50	1.37	4.67	17.0	3.39	3.52	0.320	0.483	17.0	3.27	97.90	88.64	4.73	6.83	-0.768	0.514	3.63	0.955	30.4	
1000S200-43 ¹	0.0451	33	0.672	2.29	9.09	1.82	3.68	0.309	0.677	8.60	1.47	29.05	25.50	0.456	6.24	-1.15	0.743	3.91	0.914	49.3	
1000S200-54	0.0566	50	0.839	2.86	11.3	2.26	3.67	0.378	0.671	10.8	1.71	51.05	45.27	0.896	7.67	-1.14	0.737	3.90	0.915	39.8	
1000S200-68	0.0713	50	1.05	3.57	14.0	2.80	3.65	0.460	0.662	13.7	2.42	72.47	62.49	1.78	9.40	-1.12	0.729	3.88	0.917	39.6	
1000S200-97	0.1017	50	1.47	5.02	19.3	3.87	3.62	0.610	0.643	19.3	3.74	112.01	101.24	5.08	12.7	-1.09	0.711	3.84	0.920	39.0	
1000S250-43 ¹	0.0451	33	0.717	2.44	10.2	2.04	3.77	0.531	0.860	10.2	1.62	31.95	27.00	0.486	10.5	-1.52	0.965	4.16	0.867	60.7	
1000S250-54	0.0566	50	0.896	3.05	12.7	2.54	3.76	0.653	0.854	12.7	1.88	56.27	47.79	0.957	12.9	-1.50	0.958	4.14	0.868	49.1	
1000S250-68	0.0713	50	1.12	3.81	15.8	3.15	3.75	0.799	0.844	15.7	2.77	82.90	66.07	1.90	15.9	-1.49	0.950	4.12	0.870	48.8	
1000S250-97	0.1017	50	1.58	5.36	21.8	4.37	3.72	1.07	0.825	21.8	4.18	141*	107.61	5.43	21.6	-1.45	0.932	4.08	0.873	48.4	
1000S300-54	0.0566	50	0.95	3.24	14.1	2.82	3.84	1.02	1.04	13.4	1.90	56.97	49.32	1.02	19.9	-1.89	1.19	4.41	0.816	58.0	
1000S300-68	0.0713	50	1.19	4.06	17.5	3.50	3.83	1.26	1.03	17.1	2.80	83.90	68.34	2.02	24.6	-1.87	1.18	4.39	0.818	57.8	
1000S300-97	0.1017	50	1.68	5.71	24.3	4.86	3.81	1.70	1.01	24.0	4.50	134.70	111.91	5.78	33.6	-1.84	1.16	4.35	0.821	57.4	
1000T125-43 ¹	0.0451	33	0.563	1.92	6.63	1.31	3.43	0.0474	0.290	5.89	0.819	16.19	—	0.382	0.973	-0.379	0.259	3.46	0.988	—	
1000T125-54	0.0566	50	0.707	2.41	8.34	1.63	3.43	0.0587	0.288	7.48	1.06	31.59	—	0.755	1.21	-0.376	0.256	3.47	0.988	—	
1000T125-68	0.0713	50	0.890	3.03	10.5	2.05	3.44	0.0727	0.286	10.2	1.57	47.15	—	1.51	1.51	-0.372	0.253	3.47	0.989	—	
1000T125-97	0.1017	50	1.27	4.32	15.1	2.91	3.45	0.100	0.281	15.1	2.75	82.42	—	4.38	2.12	-0.363	0.247	3.48	0.989	—	
1000T150-43 ¹	0.0451	33	0.586	1.99	7.21	1.42	3.51	0.0804	0.370	6.20	0.837	16.54	—	0.397	1.61	-0.513	0.345	3.56	0.979	—	
1000T150-54	0.0566	50	0.735	2.50	9.06	1.78	3.51	0.100	0.368	7.88	1.08	32.30	—	0.785	2.01	-0.509	0.342	3.57	0.980	—	
1000T150-68	0.0713	50	0.926	3.15	11.4	2.23	3.52	0.124	0.366	10.8	1.62	48.53	—	1.57	2.52	-0.505	0.339	3.57	0.980	—	
1000T150-97	0.1017	50	1.32	4.49	16.4	3.17	3.53	0.172	0.361	16.4	2.90	86.90	—	4.55	3.56	-0.495	0.332	3.58	0.981	—	
1000T200-43 ¹	0.0451	33	0.631	2.15	8.36	1.65	3.64	0.183	0.539	6.72	0.861	17.01	—	0.428	3.54	-0.813	0.534	3.77	0.953	—	
1000T200-54	0.0566	50	0.792	2.69	10.5	2.06	3.65	0.228	0.537	8.56	1.11	33.26	—	0.845	4.43	-0.809	0.531	3.77	0.954	—	
1000T200-68	0.0713	50	0.997	3.39	13.3	2.59	3.65	0.284	0.534	11.8	1.68	50.42	—	1.69	5.58	-0.803	0.527	3.78	0.955	—	
1000T200-97	0.1017	50	1.42	4.84	19.1	3.69	3.66	0.397	0.528	18.6	3.08	92.26	—	4.90	7.92	-0.791	0.519	3.79	0.956	—	
1000T300-43 ¹	0.0451	33	0.721	2.45	10.7	2.10	3.85	0.572	0.890	8.56	0.919	18.16	—	0.489	10.6	-1.50	0.950	4.23	0.873	—	
1000T300-54	0.0566	50	0.905	3.08	13.4	2.63	3.85	0.714	0.888	10.8	1.19	35.66	—	0.966	13.3	-1.50	0.947	4.23	0.874	—	
1000T300-68	0.0713	50	1.14	3.88	17.0	3.32	3.86	0.893	0.885	14.1	1.90	57.02	—	1.93	16.8	-1.49	0.943	4.23	0.876	—	
1000T300-97	0.1017	50	1.62	5.53	24.4	4.72	3.88	1.26	0.879	21.5	3.59	107.46	—	5.60	24.0	-1.48	0.934	4.24	0.879	—	

For additional general notes, see page 6

¹Web-height-to-thickness ratio exceeds 200. Web stiffeners are required at all support points and concentrated loads.

*Allowable moment includes cold work of forming.

Gross Properties:

Ix = Moment of Inertia of cross-section about the x-axis.
 Sx = Section Modulus about the x-axis.
 Rx = Radius of Gyration of cross-section about the x-axis.
 Iy = Moment of Inertia of cross-section about the y-axis.
 Ry = Radius of Gyration of cross-section about the y-axis.

Effective Properties:

Ixe = Effective Moment of Inertia of cross-section about the x-axis.
 Sxe = Effective Section Modulus about the x-axis.
 Ma = Allowable Moment based on local buckling.
 Mad = Allowable Moment based on distortional buckling, assuming $K\phi=0$.

Torsional and Other Properties:

J = St. Venant Torsional Constant. The values of J shown in the tables have been factored by 1000.
 Cw = Torsional Warping Constant.
 Xo = Distance from shear center to the centroid along the principal axis.
 m = Distance from shear center to mid-plane of web.

Ro = Polar Radius of Gyration of cross-section about the shear center.
 Beta = $1-(Xo/Ro)^2$
 Lu = Critical unbraced length for lateral-torsional buckling. Members are considered fully braced when unbraced length is less than Lu.

Complies with AISI S100-16 (2020) w/S2-20 • IBC 2024

12" STUD/TRACK PROPERTIES

Member	Design thickness (in)	Yield strength Fy (ksi)	Gross Properties								Effective Properties				Torsional Properties						Lu (in)
			Area (in ²)	Weight (lb/ft)	Ix (in ⁴)	Sx (in ³)	Rx (in)	Iy (in ⁴)	Ry (in)	Ixe (in ⁴)	Sxe (in ³)	Ma (in-k)	Mad (in-k)	Jx1000 (in ⁴)	Cw (in ⁶)	Xo (in)	m (in)	Ro (in)	β		
12" Stud	1200S162-54 ¹	0.0566	50	0.896	3.05	15.7	2.62	4.19	0.212	0.486	14.3	1.91	57.32	45.22	0.957	6.34	-0.732	0.493	4.28	0.971	30.5
	1200S162-68	0.0713	50	1.12	3.81	19.5	3.25	4.17	0.255	0.477	18.4	2.65	79.20	63.71	1.90	7.74	-0.719	0.485	4.26	0.972	30.2
	1200S162-97	0.1017	50	1.58	5.36	27.0	4.50	4.14	0.332	0.459	26.7	4.09	122.50	106.58	5.43	10.3	-0.691	0.470	4.22	0.973	29.5
	1200S200-54 ¹	0.0566	50	0.953	3.24	17.7	2.94	4.31	0.394	0.643	16.3	2.07	62.07	53.30	1.02	11.6	-1.03	0.681	4.48	0.947	39.0
	1200S200-68	0.0713	50	1.19	4.06	22.0	3.66	4.29	0.479	0.634	20.9	2.96	88.72	74.35	2.02	14.2	-1.02	0.673	4.46	0.948	38.7
	1200S200-97	0.1017	50	1.68	5.71	30.4	5.07	4.26	0.635	0.615	30.2	4.66	139.52	122.78	5.78	19.1	-0.987	0.656	4.41	0.950	38.1
	1200S250-54 ¹	0.0566	50	1.01	3.43	19.7	3.28	4.42	0.683	0.823	18.4	2.15	64.34	56.90	1.08	19.5	-1.38	0.892	4.70	0.914	48.3
	1200S250-68	0.0713	50	1.26	4.30	24.5	4.08	4.40	0.836	0.813	23.6	3.01	90.04	79.32	2.14	24.0	-1.36	0.884	4.68	0.915	48.1
	1200S250-97	0.1017	50	1.78	6.05	34.0	5.67	4.37	1.12	0.794	33.8	5.04	150.83	131.17	6.13	32.7	-1.33	0.867	4.64	0.918	47.5
	1200S300-54 ¹	0.0566	50	1.07	3.63	21.7	3.62	4.51	1.07	1.00	21.0	2.27	68.04	59.15	1.14	30.1	-1.74	1.11	4.94	0.876	57.4
1200S300-68	0.0713	50	1.33	4.54	27.0	4.50	4.50	1.32	0.994	26.5	3.32	99.33	82.50	2.26	37.1	-1.73	1.10	4.92	0.877	57.2	
1200S300-97	0.1017	50	1.88	6.40	37.6	6.27	4.47	1.79	0.975	37.1	5.83	174.58	136.78	6.48	50.9	-1.69	1.08	4.88	0.880	56.7	
12" Track	1200T125-54 ¹	0.0566	50	0.820	2.79	13.3	2.19	4.03	0.0601	0.271	11.5	1.29	38.51	—	0.88	1.82	-0.333	0.230	4.06	0.993	—
	1200T125-68	0.0713	50	1.03	3.51	16.8	2.75	4.04	0.0744	0.268	15.7	1.93	57.90	—	1.75	2.27	-0.329	0.227	4.06	0.993	—
	1200T125-97	0.1017	50	1.47	5.01	24.1	3.90	4.04	0.102	0.264	23.8	3.44	103.07	—	5.08	3.17	-0.322	0.222	4.07	0.994	—
	1200T150-54 ¹	0.0566	50	0.848	2.89	14.4	2.36	4.12	0.103	0.348	12.0	1.31	39.32	—	0.91	3.03	-0.454	0.310	4.16	0.988	—
	1200T150-68	0.0713	50	1.07	3.64	18.2	2.96	4.12	0.127	0.345	16.6	1.99	59.48	—	1.81	3.79	-0.450	0.307	4.16	0.988	—
	1200T150-97	0.1017	50	1.52	5.18	26.0	4.21	4.13	0.176	0.340	25.7	3.62	108.27	—	5.25	5.33	-0.441	0.301	4.17	0.989	—
	1200T200-54 ¹	0.0566	50	0.905	3.08	16.5	2.70	4.27	0.236	0.510	13.0	1.35	40.42	—	0.97	6.71	-0.730	0.487	4.36	0.972	—
	1200T200-68	0.0713	50	1.14	3.88	20.8	3.40	4.27	0.294	0.508	18.0	2.06	61.63	—	1.93	8.43	-0.725	0.483	4.36	0.972	—
	1200T200-97	0.1017	50	1.62	5.53	29.8	4.83	4.28	0.410	0.502	29.0	3.82	114.35	—	5.60	11.9	-0.714	0.476	4.37	0.973	—
	1200T300-54 ¹	0.0566	50	1.02	3.46	20.6	3.38	4.50	0.745	0.855	14.5	1.39	41.65	—	1.09	20.2	-1.37	0.884	4.79	0.917	—
1200T300-68	0.0713	50	1.28	4.36	26.1	4.26	4.51	0.932	0.852	20.3	2.14	64.06	—	2.17	25.5	-1.37	0.880	4.79	0.918	—	
1200T300-97	0.1017	50	1.83	6.22	37.5	6.06	4.53	1.31	0.847	33.4	4.05	121.31	—	6.30	36.4	-1.36	0.871	4.80	0.920	—	

For additional general notes, see page 6

¹Web-height-to-thickness ratio exceeds 200. Web stiffeners are required at all support points and concentrated loads.

*Allowable moment includes cold work of forming.

Gross Properties:

- Ix = Moment of Inertia of cross-section about the x-axis.
- Sx = Section Modulus about the x-axis.
- Rx = Radius of Gyration of cross-section about the x-axis.
- Iy = Moment of Inertia of cross-section about the y-axis.
- Ry = Radius of Gyration of cross-section about the y-axis.

Effective Properties:

- Ixe = Effective Moment of Inertia of cross-section about the x-axis.
- Sxe = Effective Section Modulus about the x-axis.
- Ma = Allowable Moment based on local buckling.
- Mad = Allowable Moment based on distortional buckling, assuming $K\phi=0$.

Torsional and Other Properties:

- J = St. Venant Torsional Constant. The values of J shown in the tables have been factored by 1000.
- Cw = Torsional Warping Constant.
- Xo = Distance from shear center to the centroid along the principal axis.
- m = Distance from shear center to mid-plane of web.

- Ro = Polar Radius of Gyration of cross-section about the shear center.
- Beta = $1-(Xo/Ro)^2$
- Lu = Critical unbraced length for lateral-torsional buckling. Members are considered fully braced when unbraced length is less than Lu.

Complies with AISI S100-16 (2020) w/S2-20 • IBC 2024

14" STUD/TRACK PROPERTIES

Member	Design thickness (in)	Yield strength Fy (ksi)	Gross Properties								Effective Properties				Torsional Properties					Lu (in)	
			Area (in ²)	Weight (lb/ft)	Ix (in ⁴)	Sx (in ³)	Rx (in)	Iy (in ⁴)	Ry (in)	Ixe (in ⁴)	Sxe (in ³)	Ma (in-k)	Mad (in-k)	Jx1000 (in ⁴)	Cw (in ⁶)	Xo (in)	m (in)	Ro (in)	β		
14" Stud	1400S162-54 ¹	0.0566	50	1.01	3.43	23.3	3.33	4.81	0.218	0.464	20.4	2.26	67.54	50.50	1.08	8.98	-0.667	0.454	4.87	0.981	29.7
	1400S162-68	0.0713	50	1.26	4.30	29.0	4.14	4.79	0.262	0.456	26.4	3.13	93.86	71.88	2.14	11.0	-0.654	0.447	4.85	0.982	29.4
	1400S162-97	0.1017	50	1.78	6.05	40.1	5.73	4.75	0.341	0.438	38.9	4.91	147.15	122.44	6.13	14.7	-0.628	0.433	4.81	0.983	28.7
	1400S200-54 ¹	0.0566	50	1.07	3.63	26.0	3.71	4.94	0.406	0.617	23.2	2.44	73.06	60.19	1.14	16.4	-0.946	0.633	5.06	0.965	38.2
	1400S200-68	0.0713	50	1.33	4.54	32.3	4.61	4.92	0.494	0.608	29.8	3.50	104.93	84.76	2.26	20.1	-0.932	0.625	5.04	0.966	37.9
	1400S200-97	0.1017	50	1.88	6.40	44.9	6.41	4.88	0.655	0.590	43.6	5.58	167.08	142.38	6.48	27.2	-0.904	0.609	5.00	0.967	37.3
	1400S250-54 ¹	0.0566	50	1.12	3.82	28.7	4.10	5.06	0.707	0.794	26.1	2.53	75.65	65.03	1.20	27.7	-1.27	0.835	5.28	0.942	47.6
	1400S250-68	0.0713	50	1.41	4.78	35.8	5.11	5.04	0.865	0.784	33.6	3.55	106.30	91.38	2.38	34.1	-1.26	0.827	5.26	0.943	47.3
	1400S250-97	0.1017	50	1.98	6.75	49.8	7.11	5.01	1.16	0.765	48.7	6.01	179.96	153.28	6.84	46.5	-1.23	0.811	5.22	0.945	46.7
	1400S300-54 ¹	0.0566	50	1.18	4.01	31.5	4.49	5.17	1.11	0.972	27.2	2.58	77.26	68.23	1.26	42.7	-1.62	1.05	5.50	0.914	56.8
1400S300-68	0.0713	50	1.48	5.03	39.2	5.60	5.15	1.37	0.963	36.3	3.66	109.43	95.79	2.50	52.8	-1.60	1.04	5.48	0.915	56.5	
1400S300-97	0.1017	50	2.08	7.09	54.7	7.81	5.12	1.85	0.943	53.2	6.37	190.80	160.72	7.19	72.4	-1.57	1.02	5.44	0.917	55.9	
14" Track	1400T125-54 ¹	0.0566	50	0.933	3.18	20.0	2.82	4.63	0.0611	0.256	16.4	1.52	45.42	—	1.00	2.56	-0.299	0.209	4.64	1.00	—
	1400T125-68	0.0713	50	1.18	4.00	25.2	3.54	4.63	0.0757	0.254	22.6	2.29	68.65	—	1.99	3.19	-0.296	0.206	4.65	1.00	—
	1400T125-97	0.1017	50	1.68	5.70	36.0	5.02	4.64	0.104	0.249	34.6	4.13	123.77	—	5.78	4.44	-0.289	0.201	4.65	1.00	—
	1400T150-54 ¹	0.0566	50	0.962	3.27	21.4	3.01	4.72	0.105	0.330	17.2	1.55	46.33	—	1.03	4.28	-0.410	0.283	4.75	0.993	—
	1400T150-68	0.0713	50	1.21	4.12	27.0	3.79	4.72	0.130	0.328	23.8	2.35	70.42	—	2.05	5.35	-0.407	0.280	4.75	0.993	—
	1400T150-97	0.1017	50	1.73	5.88	38.6	5.38	4.73	0.180	0.323	37.3	4.33	129.70	—	5.95	7.50	-0.399	0.275	4.76	0.993	—
	1400T200-54 ¹	0.0566	50	1.02	3.46	24.2	3.41	4.88	0.242	0.487	18.4	1.59	47.57	—	1.09	9.52	-0.665	0.449	4.95	0.982	—
	1400T200-68	0.0713	50	1.28	4.36	30.6	4.29	4.88	0.301	0.485	25.7	2.43	72.82	—	2.17	11.9	-0.661	0.446	4.95	0.982	—
	1400T200-97	0.1017	50	1.83	6.22	43.8	6.10	4.89	0.420	0.479	41.8	4.56	136.49	—	6.30	16.9	-0.651	0.439	4.96	0.983	—
	1400T300-54 ¹	0.0566	50	1.13	3.85	29.9	4.21	5.14	0.769	0.825	20.3	1.64	48.97	—	1.21	28.8	-1.27	0.829	5.36	0.944	—
1400T300-68	0.0713	50	1.42	4.85	37.7	5.30	5.15	0.962	0.822	28.8	2.52	75.54	—	2.41	36.3	-1.26	0.825	5.36	0.944	—	
1400T300-97	0.1017	50	2.03	6.91	54.1	7.54	5.16	1.35	0.816	47.6	4.82	144.18	—	7.00	51.6	-1.25	0.817	5.37	0.946	—	

For additional general notes, see page 6

¹Web-height-to-thickness ratio exceeds 200. Web stiffeners are required at all support points and concentrated loads.

*Allowable moment includes cold work of forming.

Gross Properties:

Ix = Moment of Inertia of cross-section about the x-axis.
 Sx = Section Modulus about the x-axis.
 Rx = Radius of Gyration of cross-section about the x-axis.
 Iy = Moment of Inertia of cross-section about the y-axis.
 Ry = Radius of Gyration of cross-section about the y-axis.

Effective Properties:

Ixe = Effective Moment of Inertia of cross-section about the x-axis.
 Sxe = Effective Section Modulus about the x-axis.
 Ma = Allowable Moment based on local buckling.
 Mad = Allowable Moment based on distortional buckling, assuming $K\phi=0$.

Torsional and Other Properties:

J = St. Venant Torsional Constant. The values of J shown in the tables have been factored by 1000.
 Cw = Torsional Warping Constant.
 Xo = Distance from shear center to the centroid along the principal axis.
 m = Distance from shear center to mid-plane of web.

Ro = Polar Radius of Gyration of cross-section about the shear center.
 Beta = $1-(Xo/Ro)^2$
 Lu = Critical unbraced length for lateral-torsional buckling. Members are considered fully braced when unbraced length is less than Lu.

Complies with AISI S100-16 (2020) w/S2-20 • IBC 2024

ALLOWABLE STUD SHEAR (LBS)

Member		Solid Section	Perforated Section	Member		Solid Section	Perforated Section
Size (in)	mil (ksi)			Size (in)	mil (ksi)		
2.5	33 (33)	975	399	6	33 (33)	638	638
	43 (33)	1265	394		43 (33)	1416	1240
	54 (50)	2353	565		54 (50)	2823	1947
	68 (50)	2866	519		68 (50)	5350	2879
	97 (50)	3798	429		97 (50)	10472	3806
3.5	33 (33)	1024	487	8	33 (33) ¹	474	474
	43 (33)	1739	631		43 (33)	1051	1051
	54 (50)	3372	947		54 (50)	2091	2091
	68 (50)	4203	897		68 (50)	4221	3367
	97 (50)	5705	775		97 (50)	10885	5938
3.625	33 (33)	1024	521	10	33 (33) ¹	377	377
	43 (33)	1739	676		43 (33) ¹	836	836
	54 (50)	3372	1016		54 (50)	1661	1661
	68 (50)	4370	1004		68 (50)	3345	3345
	97 (50)	5943	875		97 (50)	9864	7177
4	33 (33)	976	595	12	33 (33) ¹	313	313
	43 (33)	1739	810		43 (33) ¹	694	694
	54 (50)	3372	1223		54 (50) ¹	1377	1377
	68 (50)	4871	1356		68 (50)	2771	2771
	97 (50)	6658	1207		97 (50)	8147	7411
5.5	33 (33)	699	699	14	33 (33) ¹	268	268
	43 (33)	1550	1199		43 (33) ¹	593	593
	54 (50)	3093	1881		54 (50) ¹	1177	1177
	68 (50)	5350	2532		68 (50)	2365	2365
	97 (50)	9518	3026		97 (50)	6939	6939

ALLOWABLE TRACK SHEAR (LBS)

Member		Solid Section	Member		Solid Section
Size (in)	mil (ksi)		Size (in)	mil (ksi)	
2.5	33 (33)	1024	6	33 (33)	622
	43 (33)	1356		43 (33)	1377
	54 (50)	2563		54 (50)	2728
	68 (50)	3199		68 (50)	5350
	97 (50)	4476		97 (50)	10885
3.5	33 (33)	1024	8	33 (33) ¹	465
	43 (33)	1739		43 (33)	1030
	54 (50)	3372		54 (50)	2039
	68 (50)	4536		68 (50)	4087
	97 (50)	6383		97 (50)	10885
3.625	33 (33)	1024	10	33 (33) ¹	372
	43 (33)	1739		43 (33) ¹	822
	54 (50)	3372		54 (50)	1628
	68 (50)	4703		68 (50)	3261
	97 (50)	6622		97 (50)	9507
4	33 (33)	940	12	33 (33) ¹	309
	43 (33)	1739		43 (33) ¹	684
	54 (50)	3372		54 (50) ¹	1354
	68 (50)	5205		68 (50)	2713
	97 (50)	7337		97 (50)	7902
5.5	33 (33)	680	14	33 (33) ¹	265
	43 (33)	1504		43 (33) ¹	586
	54 (50)	2980		54 (50) ¹	1160
	68 (50)	5350		68 (50)	2322
	97 (50)	10197		97 (50)	6761

¹ Web-height to thickness ratio exceeds 200. Web stiffeners are required at all support points and concentrated loads.

Notes for Allowable Stud Shear:

- 1 Capacities are calculated per AISI S100-16 (2020) w/S2-20.
- 2 For perforated sections, the standard ClarkDietrich oval knockout of 1-1/2" (3/4" for 2-1/2" webs) x 4" is used.

Complies with AISI S100-16 (2020) w/S2-20 • IBC 2024



ALLOWABLE WALL HEIGHT TABLES

INTERIOR WALL HEIGHTS

With structural framing

Member	Spacing (in) o.c.	5psf		
		L/120	L/240	L/360
250S137-33	12	17' 6"	13' 10"	12' 1"
	16	15' 10"	12' 7"	11' 0"
	24	13' 10"	11' 0"	9' 7"
250S137-43	12	19' 0"	15' 1"	13' 2"
	16	17' 3"	13' 8"	11' 11"
	24	15' 1"	11' 11"	10' 5"
250S137-54	12	20' 3"	16' 1"	14' 1"
	16	18' 5"	14' 8"	12' 9"
	24	16' 1"	12' 9"	11' 2"
250S137-68	12	21' 8"	17' 2"	15' 0"
	16	19' 8"	15' 7"	13' 8"
	24	17' 2"	13' 8"	11' 11"
250S137-97	12	23' 8"	18' 10"	16' 5"
	16	21' 6"	17' 1"	14' 11"
	24	18' 10"	14' 11"	13' 0"
250S162-33	12	18' 4"	14' 7"	12' 9"
	16	16' 8"	13' 3"	11' 7"
	24	14' 7"	11' 7"	10' 1"
250S162-43	12	19' 11"	15' 10"	13' 10"
	16	18' 1"	14' 4"	12' 7"
	24	15' 10"	12' 7"	11' 0"
250S162-54	12	21' 4"	16' 11"	14' 9"
	16	19' 4"	15' 5"	13' 5"
	24	16' 11"	13' 5"	11' 9"
250S162-68	12	22' 9"	18' 1"	15' 9"
	16	20' 8"	16' 5"	14' 4"
	24	18' 1"	14' 4"	12' 6"
250S162-97	12	25' 0"	19' 10"	17' 4"
	16	22' 9"	18' 0"	15' 9"
	24	19' 10"	15' 9"	13' 9"

Member	Spacing (in) o.c.	5psf		
		L/120	L/240	L/360
250S200-33	12	19' 4"	15' 4"	13' 5"
	16	17' 7"	13' 11"	12' 2"
	24	15' 4"	12' 2"	10' 8"
250S200-43	12	21' 1"	16' 9"	14' 8"
	16	19' 2"	15' 3"	13' 4"
	24	16' 9"	13' 4"	11' 7"
250S200-54	12	22' 7"	17' 11"	15' 8"
	16	20' 6"	16' 4"	14' 3"
	24	17' 11"	14' 3"	12' 5"
250S200-68	12	24' 2"	19' 2"	16' 9"
	16	21' 11"	17' 5"	15' 3"
	24	19' 2"	15' 3"	13' 4"
250S200-97	12	26' 7"	21' 1"	18' 5"
	16	24' 2"	19' 2"	16' 9"
	24	21' 1"	16' 9"	14' 8"
250S250-43	12	22' 4"	17' 9"	15' 6"
	16	20' 4"	16' 1"	14' 1"
	24	17' 9"	14' 1"	12' 4"
250S250-54	12	23' 11"	19' 0"	16' 7"
	16	21' 9"	17' 3"	15' 1"
	24	19' 0"	15' 1"	13' 2"
250S250-68	12	25' 8"	20' 4"	17' 9"
	16	23' 4"	18' 6"	16' 2"
	24	20' 4"	16' 2"	14' 1"
250S250-97	12	28' 4"	22' 6"	19' 8"
	16	25' 9"	20' 5"	17' 10"
	24	22' 6"	17' 10"	15' 7"

Notes:

- 1 Studs are checked for simple-span deflection and stress. Stress calculations are made for mid-span fully braced moment, end shear through the unperforated section and shear moment interaction through the perforated section 10" away from the end bearing.
- 2 A 1/3 stress increase is not used.
- 3 Limiting heights are based on continuous lateral support of each flange over the full height of the stud.

- 4 Listed limiting heights are based on steel properties only.
- 5 End reactions must be checked for web crippling separately.
- 6 Web crippling check based on 1-inch end bearing. Where limiting heights are followed by "e", web stiffeners are required.
- 7 Allowable moment is the lesser of local and distortional buckling. Stud distortional buckling based on an assumed $K\phi = 0$.

- 8 Members marked with an ¹ have $h/t > 200$, and thus require end stiffeners.
- 9 Capacities are calculated according to the AISI S100-16 (2020) w/S2-20. A 1-1/2" by 4" knockout spaced no closer than 24" o.c. is assumed. (3/4" for 2-1/2" studs).
- 10 All values are based on $F_y=33\text{ksi}$ for 33mil and 43mil Studs, and $F_y=50\text{ksi}$ for 54mil, 68mil and 97mil Studs.
- 11 For deflection calculations, interior wall loads have been multiplied by 1.0 per AISI S240.

Complies with AISI S100-16 (2020) w/S2-20 • IBC 2024

INTERIOR WALL HEIGHTS

With structural framing

Member	Spacing (in) o.c.	5psf		
		L/120	L/240	L/360
350S137-33	12	22' 7"	17' 11"	15' 8"
	16	20' 7"	16' 4"	14' 3"
	24	17' 2"	14' 3"	12' 5"
350S137-43	12	24' 7"	19' 6"	17' 1"
	16	22' 4"	17' 9"	15' 6"
	24	19' 6"	15' 6"	13' 6"
350S137-54	12	26' 4"	20' 11"	18' 3"
	16	23' 11"	19' 0"	16' 7"
	24	20' 11"	16' 7"	14' 6"
350S137-68	12	28' 2"	22' 4"	19' 6"
	16	25' 7"	20' 3"	17' 9"
	24	22' 4"	17' 9"	15' 6"
350S137-97	12	30' 11"	24' 7"	21' 5"
	16	28' 1"	22' 4"	19' 6"
	24	24' 7"	19' 6"	17' 0"
350S162-33	12	23' 9"	18' 10"	16' 5"
	16	21' 7"	17' 1"	14' 11"
	24	18' 5"	14' 11"	13' 1"
350S162-43	12	25' 10"	20' 6"	17' 11"
	16	23' 5"	18' 7"	16' 3"
	24	20' 6"	16' 3"	14' 2"
350S162-54	12	27' 8"	21' 11"	19' 2"
	16	25' 1"	19' 11"	17' 5"
	24	21' 11"	17' 5"	15' 2"
350S162-68	12	29' 7"	23' 6"	20' 6"
	16	26' 10"	21' 4"	18' 7"
	24	23' 6"	18' 7"	16' 3"
350S162-97	12	32' 7"	25' 10"	22' 7"
	16	29' 7"	23' 6"	20' 6"
	24	25' 10"	20' 6"	17' 11"

Member	Spacing (in) o.c.	5psf		
		L/120	L/240	L/360
350S200-33	12	24' 11"	19' 10"	17' 4"
	16	22' 8"	18' 0"	15' 9"
	24	19' 4"	15' 9"	13' 9"
350S200-43	12	27' 3"	21' 8"	18' 11"
	16	24' 9"	19' 8"	17' 2"
	24	21' 8"	17' 2"	15' 0"
350S200-54	12	29' 3"	23' 2"	20' 3"
	16	26' 6"	21' 1"	18' 5"
	24	23' 2"	18' 5"	16' 1"
350S200-68	12	31' 3"	24' 10"	21' 8"
	16	28' 5"	22' 7"	19' 8"
	24	24' 10"	19' 8"	17' 3"
350S200-97	12	34' 7"	27' 5"	24' 0"
	16	31' 5"	24' 11"	21' 9"
	24	27' 5"	21' 9"	19' 0"
350S250-43	12	28' 9"	22' 10"	19' 11"
	16	26' 1"	20' 9"	18' 1"
	24	22' 10"	18' 1"	15' 10"
350S250-54	12	30' 9"	24' 5"	21' 4"
	16	27' 11"	22' 2"	19' 4"
	24	24' 5"	19' 4"	16' 11"
350S250-68	12	33' 1"	26' 3"	22' 11"
	16	30' 0"	23' 10"	20' 10"
	24	26' 3"	20' 10"	18' 2"
350S250-97	12	36' 7"	29' 1"	25' 5"
	16	33' 3"	26' 5"	23' 1"
	24	29' 1"	23' 1"	20' 2"

Notes:

- 1 Studs are checked for simple-span deflection and stress. Stress calculations are made for mid-span fully braced moment, end shear through the unperforated section and shear moment interaction through the perforated section 10" away from the end bearing.
- 2 A 1/3 stress increase is not used.
- 3 Limiting heights are based on continuous lateral support of each flange over the full height of the stud.

- 4 Listed limiting heights are based on steel properties only.
- 5 End reactions must be checked for web crippling separately.
- 6 Web crippling check based on 1-inch end bearing. Where limiting heights are followed by "e", web stiffeners are required.
- 7 Allowable moment is the lesser of local and distortional buckling. Stud distortional buckling based on an assumed $K\phi = 0$.

- 8 Members marked with an ¹ have $h/t > 200$, and thus require end stiffeners.
- 9 Capacities are calculated according to the AISI S100-16 (2020) w/S2-20. A 1-1/2" by 4" knockout spaced no closer than 24" o.c. is assumed. (3/4" for 2-1/2" studs).
- 10 All values are based on $F_y=33\text{ksi}$ for 33mil and 43mil Studs, and $F_y=50\text{ksi}$ for 54mil, 68mil and 97mil Studs.
- 11 For deflection calculations, interior wall loads have been multiplied by 1.0 per AISI S240.

INTERIOR WALL HEIGHTS

With structural framing

Member	Spacing (in) o.c.	5psf		
		L/120	L/240	L/360
362S137-33	12	23' 3"	18' 5"	16' 1"
	16	21' 1"	16' 9"	14' 8"
	24	17' 6"	14' 8"	12' 10"
362S137-43	12	25' 3"	20' 1"	17' 6"
	16	23' 0"	18' 3"	15' 11"
	24	20' 1"	15' 11"	13' 11"
362S137-54	12	27' 1"	21' 6"	18' 9"
	16	24' 7"	19' 6"	17' 1"
	24	21' 6"	17' 1"	14' 11"
362S137-68	12	28' 11"	22' 11"	20' 1"
	16	26' 3"	20' 10"	18' 3"
	24	22' 11"	18' 3"	15' 11"
362S137-97	12	31' 10"	25' 3"	22' 1"
	16	28' 11"	22' 11"	20' 1"
	24	25' 3"	20' 1"	17' 6"
362S162-33	12	24' 4"	19' 4"	16' 11"
	16	22' 2"	17' 7"	15' 4"
	24	18' 9"	15' 4"	13' 5"
362S162-43	12	26' 6"	21' 0"	18' 5"
	16	24' 1"	19' 1"	16' 8"
	24	21' 0"	16' 8"	14' 7"
362S162-54	12	28' 5"	22' 6"	19' 8"
	16	25' 10"	20' 6"	17' 11"
	24	22' 6"	17' 11"	15' 7"
362S162-68	12	30' 5"	24' 1"	21' 1"
	16	27' 7"	21' 11"	19' 2"
	24	24' 1"	19' 2"	16' 9"
362S162-97	12	33' 6"	26' 7"	23' 3"
	16	30' 5"	24' 2"	21' 1"
	24	26' 7"	21' 1"	18' 5"

3-5/8" Structural Framing

Member	Spacing (in) o.c.	5psf		
		L/120	L/240	L/360
362S200-33	12	25' 8"	20' 4"	17' 9"
	16	23' 3"	18' 6"	16' 2"
	24	19' 8"	16' 2"	14' 1"
362S200-43	12	28' 0"	22' 3"	19' 5"
	16	25' 5"	20' 2"	17' 8"
	24	22' 3"	17' 8"	15' 5"
362S200-54	12	30' 0"	23' 10"	20' 10"
	16	27' 3"	21' 8"	18' 11"
	24	23' 10"	18' 11"	16' 6"
362S200-68	12	32' 2"	25' 6"	22' 3"
	16	29' 2"	23' 2"	20' 3"
	24	25' 6"	20' 3"	17' 8"
362S200-97	12	35' 6"	28' 3"	24' 8"
	16	32' 3"	25' 8"	22' 5"
	24	28' 3"	22' 5"	19' 7"
362S250-43	12	29' 6"	23' 5"	20' 6"
	16	26' 10"	21' 3"	18' 7"
	24	23' 5"	18' 7"	16' 3"
362S250-54	12	31' 7"	25' 1"	21' 11"
	16	28' 8"	22' 9"	19' 11"
	24	25' 1"	19' 11"	17' 4"
362S250-68	12	33' 11"	26' 11"	23' 6"
	16	30' 10"	24' 6"	21' 5"
	24	26' 11"	21' 5"	18' 8"
362S250-97	12	37' 7"	29' 10"	26' 1"
	16	34' 2"	27' 1"	23' 8"
	24	29' 10"	23' 8"	20' 8"

3-5/8" Structural Framing

Notes:

- 1 Studs are checked for simple-span deflection and stress. Stress calculations are made for mid-span fully braced moment, end shear through the unperforated section and shear moment interaction through the perforated section 10" away from the end bearing.
- 2 A 1/3 stress increase is not used.
- 3 Limiting heights are based on continuous lateral support of each flange over the full height of the stud.
- 4 Listed limiting heights are based on steel properties only.
- 5 End reactions must be checked for web crippling separately.
- 6 Web crippling check based on 1-inch end bearing. Where limiting heights are followed by "e", web stiffeners are required.
- 7 Allowable moment is the lesser of local and distortional buckling. Stud distortional buckling based on an assumed $K\phi = 0$.
- 8 Members marked with an ¹ have $h/t > 200$, and thus require end stiffeners.
- 9 Capacities are calculated according to the AISI S100-16 (2020) w/S2-20. A 1-1/2" by 4" knockout spaced no closer than 24" o.c. is assumed. (3/4" for 2-1/2" studs).
- 10 All values are based on $F_y=33\text{ksi}$ for 33mil and 43mil Studs, and $F_y=50\text{ksi}$ for 54mil, 68mil and 97mil Studs.
- 11 For deflection calculations, interior wall loads have been multiplied by 1.0 per AISI S240.

Complies with AISI S100-16 (2020) w/S2-20 • IBC 2024

INTERIOR WALL HEIGHTS

With structural framing

Member	Spacing (in) o.c.	5psf		
		L/120	L/240	L/360
400S137-33	12	25' 1"	19' 11"	17' 5"
	16	22' 7"	18' 1"	15' 10"
	24	18' 6"	15' 10"	13' 10"
400S137-43	12	27' 4"	21' 8"	18' 11"
	16	24' 10"	19' 8"	17' 2"
	24	21' 8"	17' 2"	15' 0"
400S137-54	12	29' 3"	23' 2"	20' 3"
	16	26' 7"	21' 1"	18' 5"
	24	23' 2"	18' 5"	16' 1"
400S137-68	12	31' 3"	24' 10"	21' 8"
	16	28' 5"	22' 7"	19' 8"
	24	24' 10"	19' 8"	17' 2"
400S137-97	12	34' 5"	27' 4"	23' 11"
	16	31' 3"	24' 10"	21' 8"
	24	27' 4"	21' 8"	18' 11"
400S162-33	12	26' 3"	20' 10"	18' 3"
	16	23' 11"	18' 11"	16' 7"
	24	19' 10"	16' 7"	14' 6"
400S162-43	12	28' 7"	22' 8"	19' 10"
	16	26' 0"	20' 7"	18' 0"
	24	22' 8"	18' 0"	15' 9"
400S162-54	12	30' 8"	24' 4"	21' 3"
	16	27' 10"	22' 1"	19' 4"
	24	24' 4"	19' 4"	16' 10"
400S162-68	12	32' 10"	26' 0"	22' 9"
	16	29' 10"	23' 8"	20' 8"
	24	26' 0"	20' 8"	18' 1"
400S162-97	12	36' 3"	28' 9"	25' 1"
	16	32' 11"	26' 1"	22' 10"
	24	28' 9"	22' 10"	19' 11"

Member	Spacing (in) o.c.	5psf		
		L/120	L/240	L/360
400S200-33	12	27' 8"	21' 11"	19' 2"
	16	25' 1"	19' 11"	17' 5"
	24	20' 10"	17' 5"	15' 2"
400S200-43	12	30' 2"	23' 11"	20' 11"
	16	27' 5"	21' 9"	19' 0"
	24	23' 11"	19' 0"	16' 7"
400S200-54	12	32' 4"	25' 8"	22' 5"
	16	29' 5"	23' 4"	20' 5"
	24	25' 8"	20' 5"	17' 10"
400S200-68	12	34' 8"	27' 6"	24' 0"
	16	31' 6"	25' 0"	21' 10"
	24	27' 6"	21' 10"	19' 1"
400S200-97	12	38' 5"	30' 6"	26' 7"
	16	34' 10"	27' 8"	24' 2"
	24	30' 6"	24' 2"	21' 1"
400S250-43	12	31' 9"	25' 3"	22' 0"
	16	28' 10"	22' 11"	20' 0"
	24	25' 3"	20' 0"	17' 6"
400S250-54	12	34' 0"	27' 0"	23' 7"
	16	30' 10"	24' 6"	21' 5"
	24	27' 0"	21' 5"	18' 8"
400S250-68	12	36' 7"	29' 0"	25' 4"
	16	33' 3"	26' 4"	23' 0"
	24	29' 0"	23' 0"	20' 1"
400S250-97	12	40' 7"	32' 2"	28' 1"
	16	36' 10"	29' 3"	25' 7"
	24	32' 2"	25' 7"	22' 4"

Notes:

- 1 Studs are checked for simple-span deflection and stress. Stress calculations are made for mid-span fully braced moment, end shear through the unperforated section and shear moment interaction through the perforated section 10" away from the end bearing.
- 2 A 1/3 stress increase is not used.
- 3 Limiting heights are based on continuous lateral support of each flange over the full height of the stud.

- 4 Listed limiting heights are based on steel properties only.
- 5 End reactions must be checked for web crippling separately.
- 6 Web crippling check based on 1-inch end bearing. Where limiting heights are followed by "e", web stiffeners are required.
- 7 Allowable moment is the lesser of local and distortional buckling. Stud distortional buckling based on an assumed $K\phi = 0$.

- 8 Members marked with an ¹ have $h/t > 200$, and thus require end stiffeners.
- 9 Capacities are calculated according to the AISI S100-16 (2020) w/S2-20. A 1-1/2" by 4" knockout spaced no closer than 24" o.c. is assumed. (3/4" for 2-1/2" studs).
- 10 All values are based on $F_y=33\text{ksi}$ for 33mil and 43mil Studs, and $F_y=50\text{ksi}$ for 54mil, 68mil and 97mil Studs.
- 11 For deflection calculations, interior wall loads have been multiplied by 1.0 per AISI S240.

Complies with AISI S100-16 (2020) w/S2-20 • IBC 2024

The technical content of this literature is effective 06/01/24 and supersedes all previous information.

INTERIOR WALL HEIGHTS

With structural framing

Member	Spacing (in) o.c.	Spsf		
		L/120	L/240	L/360
550S137-33	12	31' 7"	25' 7"	22' 5"
	16	27' 4"	23' 3"	20' 4"
	24	22' 4"	20' 4"	17' 9"
550S137-43	12	35' 2"	27' 11"	24' 4"
	16	31' 11"	25' 4"	22' 2"
	24	26' 9"	22' 2"	19' 4"
550S137-54	12	37' 8"	29' 11"	26' 1"
	16	34' 3"	27' 2"	23' 9"
	24	29' 11"	23' 9"	20' 9"
550S137-68	12	40' 4"	32' 0"	28' 0"
	16	36' 8"	29' 1"	25' 5"
	24	32' 0"	25' 5"	22' 2"
550S137-97	12	44' 7"	35' 5"	30' 11"
	16	40' 6"	32' 2"	28' 1"
	24	35' 5"	28' 1"	24' 6"
550S162-33	12	33' 8"	26' 9"	23' 4"
	16	29' 5"	24' 4"	21' 3"
	24	24' 0"	21' 3"	18' 6"
550S162-43	12	36' 8"	29' 1"	25' 5"
	16	33' 4"	26' 5"	23' 1"
	24	29' 1"	23' 1"	20' 2"
550S162-54	12	39' 4"	31' 3"	27' 3"
	16	35' 9"	28' 5"	24' 9"
	24	31' 3"	24' 9"	21' 8"
550S162-68	12	42' 2"	33' 6"	29' 3"
	16	38' 4"	30' 5"	26' 7"
	24	33' 6"	26' 7"	23' 3"
550S162-97	12	46' 9"	37' 1"	32' 5"
	16	42' 5"	33' 8"	29' 5"
	24	37' 1"	29' 5"	25' 8"

5-1/2" Structural Framing

Member	Spacing (in) o.c.	Spsf		
		L/120	L/240	L/360
550S200-33	12	35' 4"	28' 0"	24' 6"
	16	31' 4"	25' 5"	22' 3"
	24	25' 7"	22' 3"	19' 5"
550S200-43	12	38' 7"	30' 7"	26' 9"
	16	35' 1"	27' 10"	24' 4"
	24	30' 6"	24' 4"	21' 3"
550S200-54	12	41' 5"	32' 10"	28' 8"
	16	37' 7"	29' 10"	26' 1"
	24	32' 10"	26' 1"	22' 9"
550S200-68	12	44' 5"	35' 3"	30' 10"
	16	40' 4"	32' 0"	28' 0"
	24	35' 3"	28' 0"	24' 5"
550S200-97	12	49' 3"	39' 1"	34' 2"
	16	44' 9"	35' 6"	31' 1"
	24	39' 1"	31' 1"	27' 1"
550S250-43	12	40' 5"	32' 1"	28' 1"
	16	36' 9"	29' 2"	25' 6"
	24	31' 4"	25' 6"	22' 3"
550S250-54	12	43' 3"	34' 4"	30' 0"
	16	39' 3"	31' 2"	27' 3"
	24	34' 4"	27' 3"	23' 10"
550S250-68	12	46' 7"	37' 0"	32' 4"
	16	42' 4"	33' 7"	29' 4"
	24	37' 0"	29' 4"	25' 8"
550S250-97	12	51' 10"	41' 2"	35' 11"
	16	47' 1"	37' 4"	32' 8"
	24	41' 2"	32' 8"	28' 6"

5-1/2" Structural Framing

Notes:

- 1 Studs are checked for simple-span deflection and stress. Stress calculations are made for mid-span fully braced moment, end shear through the unperforated section and shear moment interaction through the perforated section 10" away from the end bearing.
- 2 A 1/3 stress increase is not used.
- 3 Limiting heights are based on continuous lateral support of each flange over the full height of the stud.
- 4 Listed limiting heights are based on steel properties only.
- 5 End reactions must be checked for web crippling separately.
- 6 Web crippling check based on 1-inch end bearing. Where limiting heights are followed by "e", web stiffeners are required.
- 7 Allowable moment is the lesser of local and distortional buckling. Stud distortional buckling based on an assumed $K\phi = 0$.
- 8 Members marked with an ¹ have $h/t > 200$, and thus require end stiffeners.
- 9 Capacities are calculated according to the AISI S100-16 (2020) w/S2-20. A 1-1/2" by 4" knockout spaced no closer than 24" o.c. is assumed. (3/4" for 2-1/2" studs).
- 10 All values are based on $F_y=33\text{ksi}$ for 33mil and 43mil Studs, and $F_y=50\text{ksi}$ for 54mil, 68mil and 97mil Studs.
- 11 For deflection calculations, interior wall loads have been multiplied by 1.0 per AISI S240.

Complies with AISI S100-16 (2020) w/S2-20 • IBC 2024

The technical content of this literature is effective 06/01/24 and supersedes all previous information.

INTERIOR WALL HEIGHTS

With structural framing

Member	Spacing (in) o.c.	Spsf		
		L/120	L/240	L/360
600S137-33	12	33' 1"	27' 3"	23' 10"
	16	28' 7"	24' 9"	21' 8"
	24	23' 4"	21' 8"	18' 11"
600S137-43	12	37' 8"	29' 11"	26' 2"
	16	34' 3"	27' 2"	23' 9"
	24	28' 1"	23' 9"	20' 9"
600S137-54	12	40' 5"	32' 1"	28' 0"
	16	36' 9"	29' 2"	25' 6"
	24	32' 1"	25' 6"	22' 3"
600S137-68	12	43' 4"	34' 4"	30' 0"
	16	39' 4"	31' 3"	27' 3"
	24	34' 4"	27' 3"	23' 10"
600S137-97	12	47' 11"	38' 0"	33' 2"
	16	43' 6"	34' 6"	30' 2"
	24	38' 0"	30' 2"	26' 4"
600S162-33	12	35' 6"	28' 8"	25' 0"
	16	30' 9"	26' 0"	22' 9"
	24	25' 2"	22' 9"	19' 10"
600S162-43	12	39' 4"	31' 2"	27' 3"
	16	35' 9"	28' 4"	24' 9"
	24	31' 1"	24' 9"	21' 8"
600S162-54	12	42' 2"	33' 6"	29' 3"
	16	38' 4"	30' 5"	26' 7"
	24	33' 6"	26' 7"	23' 3"
600S162-68	12	45' 3"	35' 11"	31' 4"
	16	41' 1"	32' 7"	28' 6"
	24	35' 11"	28' 6"	24' 11"
600S162-97	12	50' 1"	39' 9"	34' 9"
	16	45' 6"	36' 2"	31' 7"
	24	39' 9"	31' 7"	27' 7"

Member	Spacing (in) o.c.	Spsf		
		L/120	L/240	L/360
600S200-33	12	37' 9"	30' 0"	26' 2"
	16	32' 10"	27' 3"	23' 10"
	24	26' 10"	23' 10"	20' 10"
600S200-43	12	41' 3"	32' 9"	28' 7"
	16	37' 6"	29' 9"	26' 0"
	24	32' 0"	26' 0"	22' 9"
600S200-54	12	44' 4"	35' 2"	30' 9"
	16	40' 3"	32' 0"	27' 11"
	24	35' 2"	27' 11"	24' 5"
600S200-68	12	47' 7"	37' 9"	33' 0"
	16	43' 2"	34' 4"	29' 11"
	24	37' 9"	29' 11"	26' 2"
600S200-97	12	52' 10"	41' 11"	36' 7"
	16	48' 0"	38' 1"	33' 3"
	24	41' 11"	33' 3"	29' 1"
600S250-43	12	43' 3"	34' 4"	30' 0"
	16	39' 3"	31' 2"	27' 3"
	24	32' 11"	27' 3"	23' 10"
600S250-54	12	46' 3"	36' 8"	32' 1"
	16	42' 0"	33' 4"	29' 1"
	24	36' 8"	29' 1"	25' 5"
600S250-68	12	49' 10"	39' 7"	34' 7"
	16	45' 3"	35' 11"	31' 5"
	24	39' 7"	31' 5"	27' 5"
600S250-97	12	55' 5"	44' 0"	38' 5"
	16	50' 4"	40' 0"	34' 11"
	24	44' 0"	34' 11"	30' 6"

Notes:

- 1 Studs are checked for simple-span deflection and stress. Stress calculations are made for mid-span fully braced moment, end shear through the unperforated section and shear moment interaction through the perforated section 10" away from the end bearing.
- 2 A 1/3 stress increase is not used.
- 3 Limiting heights are based on continuous lateral support of each flange over the full height of the stud.

- 4 Listed limiting heights are based on steel properties only.
- 5 End reactions must be checked for web crippling separately.
- 6 Web crippling check based on 1-inch end bearing. Where limiting heights are followed by "e", web stiffeners are required.
- 7 Allowable moment is the lesser of local and distortional buckling. Stud distortional buckling based on an assumed $K\phi = 0$.

- 8 Members marked with an ¹ have $h/t > 200$, and thus require end stiffeners.
- 9 Capacities are calculated according to the AISI S100-16 (2020) w/S2-20. A 1-1/2" by 4" knockout spaced no closer than 24" o.c. is assumed. (3/4" for 2-1/2" studs).
- 10 All values are based on $F_y=33\text{ksi}$ for 33mil and 43mil Studs, and $F_y=50\text{ksi}$ for 54mil, 68mil and 97mil Studs.
- 11 For deflection calculations, interior wall loads have been multiplied by 1.0 per AISI S240.

Complies with AISI S100-16 (2020) w/S2-20 • IBC 2024

The technical content of this literature is effective 06/01/24 and supersedes all previous information.

INTERIOR WALL HEIGHTS

With structural framing

Member	Spacing (in) o.c.	Spsf		
		L/120	L/240	L/360
800S137-33 ¹	12	37' 10"	34' 0"	29' 8"
	16	32' 9"	30' 11"	27' 0"
	24	26' 9"	26' 9"	23' 7"
800S137-43	12	45' 11"	37' 5"	32' 8"
	16	39' 9"	34' 0"	29' 9"
	24	32' 5"	29' 9"	25' 11"
800S137-54	12	50' 9"	40' 3"	35' 2"
	16	46' 1"	36' 7"	31' 11"
	24	40' 3"	31' 11"	27' 11"
800S137-68	12	54' 10"	43' 6"	38' 0"
	16	49' 10"	39' 6"	34' 6"
	24	43' 6"	34' 6"	30' 2"
800S137-97	12	60' 10"	48' 4"	42' 2"
	16	55' 4"	43' 11"	38' 4"
	24	48' 4"	38' 4"	33' 6"
800S162-33 ¹	12	41' 0"	35' 5"	30' 11"
	16	35' 6"	32' 2"	28' 1"
	24	29' 0" e	28' 1"	24' 7"
800S162-43	12	49' 1"	38' 11"	34' 0"
	16	42' 10"	35' 4"	30' 11"
	24	35' 0"	30' 11"	27' 0"
800S162-54	12	52' 9"	41' 10"	36' 7"
	16	47' 11"	38' 1"	33' 3"
	24	41' 10"	33' 3"	29' 0"
800S162-68	12	57' 0"	45' 3"	39' 6"
	16	51' 10"	41' 1"	35' 11"
	24	45' 3"	35' 11"	31' 5"
800S162-97	12	63' 5"	50' 4"	43' 11"
	16	57' 7"	45' 9"	39' 11"
	24	50' 4"	39' 11"	34' 11"

8" Structural Framing

Member	Spacing (in) o.c.	Spsf		
		L/120	L/240	L/360
800S200-33 ¹	12	44' 0"	37' 9"	33' 0"
	16	38' 1"	34' 3"	29' 11"
	24	31' 1" e	29' 11" e	26' 2"
800S200-43	12	51' 10"	41' 1"	35' 11"
	16	45' 10"	37' 4"	32' 8"
	24	37' 5"	32' 8"	28' 6"
800S200-54	12	55' 8"	44' 2"	38' 7"
	16	50' 7"	40' 2"	35' 1"
	24	44' 2"	35' 1"	30' 8"
800S200-68	12	59' 9"	47' 5"	41' 5"
	16	54' 4"	43' 1"	37' 8"
	24	47' 5"	37' 8"	32' 11"
800S200-97	12	66' 6"	52' 9"	46' 1"
	16	60' 5"	47' 11"	41' 11"
	24	52' 9"	41' 11"	36' 7"
800S250-43	12	54' 0"	42' 11"	37' 6"
	16	47' 0"	39' 0"	34' 0"
	24	38' 4"	34' 0"	29' 9"
800S250-54	12	57' 10"	45' 11"	40' 1"
	16	52' 7"	41' 8"	36' 5"
	24	45' 11"	36' 5"	31' 10"
800S250-68	12	62' 4"	49' 6"	43' 3"
	16	56' 8"	44' 11"	39' 3"
	24	49' 6"	39' 3"	34' 4"
800S250-97	12	69' 6"	55' 2"	48' 2"
	16	63' 2"	50' 1"	43' 9"
	24	55' 2"	43' 9"	38' 3"

8" Structural Framing

Notes:

- 1 Studs are checked for simple-span deflection and stress. Stress calculations are made for mid-span fully braced moment, end shear through the unperforated section and shear moment interaction through the perforated section 10" away from the end bearing.
- 2 A 1/3 stress increase is not used.
- 3 Limiting heights are based on continuous lateral support of each flange over the full height of the stud.
- 4 Listed limiting heights are based on steel properties only.
- 5 End reactions must be checked for web crippling separately.
- 6 Web crippling check based on 1-inch end bearing. Where limiting heights are followed by "e", web stiffeners are required.
- 7 Allowable moment is the lesser of local and distortional buckling. Stud distortional buckling based on an assumed $K\phi = 0$.
- 8 Members marked with an ¹ have $h/t > 200$, and thus require end stiffeners.
- 9 Capacities are calculated according to the AISI S100-16 (2020) w/S2-20. A 1-1/2" by 4" knockout spaced no closer than 24" o.c. is assumed. (3/4" for 2-1/2" studs).
- 10 All values are based on $F_y=33\text{ksi}$ for 33mil and 43mil Studs, and $F_y=50\text{ksi}$ for 54mil, 68mil and 97mil Studs.
- 11 For deflection calculations, interior wall loads have been multiplied by 1.0 per AISI S240.

Complies with AISI S100-16 (2020) w/S2-20 • IBC 2024

Exterior curtain wall overview

Load/Span Table Wind Pressure Notes.

Historically there have been differences in the design wind pressures determined through different versions of the model building codes. Older versions of the codes provided service level loads (ASD) while newer versions provide strength level loads (LRFD). Since IBC 2012/ASCE 7-10 design wind pressures have been determined via strength level (LRFD) loads. The load/span tables that follow are based on service level (ASD) wind loads. Therefore, to properly use the load/span tables in this catalog, multiply the IBC 2024/ASCE 7-16 design wind pressures by 0.6 (reference section 2.4 ASCE 7-16) prior to entering the load/span tables.

Example:

- ASCE 7-16 Calculated Design Wind Pressure = 25psf (strength level loads, LRFD)
- Convert to service level load (ASD) = 25psf x 0.6 = 15psf
- Use 15psf as the Pressure Value used in this table to determine the member span

The load/span tables that follow are based on service level (ASD) wind loads. If the wind load being used meets this criterion, it does not need to be modified prior to using the tables.

Allowable wall heights—curtain wall framing.

Exterior curtain walls must be designed to withstand the highest winds anticipated for the particular construction location. Wind pressures can be found in the project's structural drawings under the "general notes" section. Please contact technical services at 888-437-3244 for help converting wind speeds (mph) to wind loads (psf).

The tables on the following pages provide allowable height limitations for exterior curtain walls subjected to lateral transverse loads. Members shown vary in depth, flange width and steel thickness. Select the studs that are right for your application, also taking into account the acceptable deflection level.

Deflection.

L/240	Length (height) of stud, in inches, divided by 240 (exterior siding or EIFS)
L/360	Length (height) of stud, in inches, divided by 360 (exterior stucco)
L/600	Length (height) of stud, in inches, divided by 600 (exterior brick)
L/720	Length (height) of stud, in inches, divided by 720 (exterior brick)

General Notes:

- 1 Studs are checked for simple-span deflection and stress. Stress calculations are made for mid-span fully braced moment, end shear through the unperforated section and shear moment interaction through the perforated section 10" away from the end bearing.
- 2 A 1/3rd stress increase is not used.
- 3 Limiting heights are based on continuous lateral support of each flange over the full height of the stud.
- 4 Listed limiting heights are based on steel properties only.
- 5 For bending, studs are assumed to be adequately braced to develop full allowable moment capacity. Stud distortional buckling based on an assumed $K\phi = 0$.
- 6 Web crippling check based on 1-inch end bearing. Web stiffeners are required when listed limiting heights are followed by "e".
- 7 Members marked with an 'l' have $h/t > 200$, and thus require end stiffeners.
- 8 Capacities are calculated according to the AISI S100-16 (2020) w/S2-20. A 1-1/2" by 4" knockout spaced no closer than 24" o.c. is assumed. (3/4" for 2-1/2" studs)
- 9 All values are based on $F_y=33\text{ksi}$ for 33mil and 43mil Studs, and $F_y=50\text{ksi}$ for 54mil, 68mil and 97mil Studs.
- 10 For deflection calculations, the 15 psf and higher ASD wind pressures have been multiplied by .7, in accordance with footnote "f" of IBC table 1604.3. The 5 psf pressure has not been reduced for deflection checks.
- 11 Lateral loads have not been modified for strength checks. Full loads are applied.
- 12 End reactions must be checked for web crippling separately.

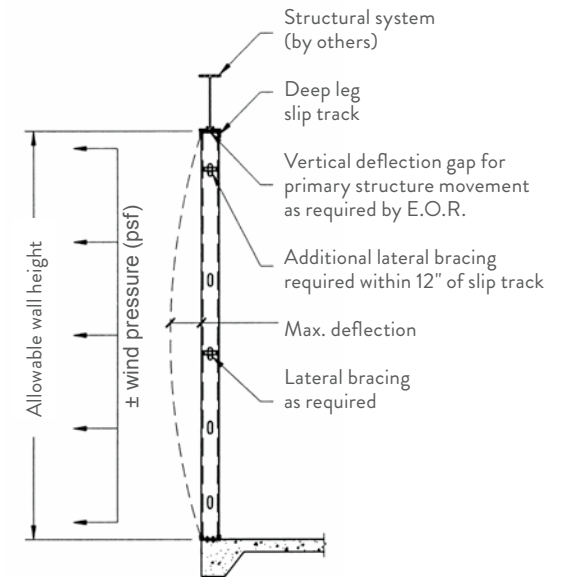

Complies with AISI S100-16 (2020) w/S2-20 • IBC 2024

The technical content of this literature is effective 06/01/24 and supersedes all previous information.

CURTAIN WALL HEIGHTS

Member	Spacing (in) o.c.	15psf			20psf			25psf			30psf			35psf			40psf		
		L/240	L/360	L/600	L/240	L/360	L/600	L/240	L/360	L/600	L/240	L/360	L/600	L/240	L/360	L/600	L/240	L/360	L/600
362S137-33	12	14' 1"	12' 7"	10' 7"	12' 3"	11' 5"	9' 8"	10' 11"	10' 7"	8' 11"	10' 0"	10' 0"	8' 5"	9' 3"	9' 3"	8' 0"	8' 8" e	8' 8" e	7' 8"
	16	12' 3"	11' 5"	9' 8"	10' 7"	10' 5"	8' 9"	9' 6"	9' 6"	8' 2"	8' 8" e	8' 8" e	7' 8"	8' 0" e	8' 0" e	7' 3" e	7' 6" e	7' 6" e	6' 11" e
	24	10' 0"	10' 0"	8' 5"	8' 8" e	8' 8" e	7' 8"	7' 9" e	7' 9" e	7' 1" e	7' 1" e	6' 8" e	6' 8" e	6' 6" e	6' 6" e	6' 4" e	6' 1" e	6' 1" e	6' 1" e
362S137-43	12	15' 8"	13' 8"	11' 7"	14' 3"	12' 5"	10' 6"	13' 0"	11' 7"	9' 9"	11' 10"	10' 10"	9' 2"	11' 0"	10' 4"	8' 8"	10' 3"	9' 10"	8' 4"
	16	14' 3"	12' 5"	10' 6"	12' 7"	11' 4"	9' 6"	11' 3"	10' 6"	8' 10"	10' 3"	9' 10"	8' 4"	9' 6"	9' 5"	7' 11"	8' 11"	8' 11"	7' 7"
	24	11' 10"	10' 10"	9' 2"	10' 3"	9' 10"	8' 4"	9' 2"	7' 9"	8' 4"	8' 4"	7' 3"	7' 9"	7' 9"	6' 11"	7' 3" e	7' 3" e	6' 7"	
362S137-54	12	16' 9"	14' 8"	12' 4"	15' 3"	13' 4"	11' 3"	14' 2"	12' 4"	10' 5"	13' 4"	11' 8"	9' 10"	12' 8"	11' 1"	9' 4"	12' 1"	10' 7"	8' 11"
	16	15' 3"	13' 4"	11' 3"	13' 10"	12' 1"	10' 2"	12' 10"	11' 3"	9' 6"	12' 1"	10' 7"	8' 11"	11' 6"	10' 0"	8' 6"	11' 0"	9' 7"	8' 1"
	24	13' 4"	11' 8"	9' 10"	12' 1"	10' 7"	8' 11"	11' 3"	9' 10"	8' 3"	10' 7"	9' 3"	7' 9"	10' 0"	8' 9"	7' 5"	9' 7"	8' 5"	7' 1"
362S137-68	12	17' 11"	15' 8"	13' 2"	16' 3"	14' 3"	12' 0"	15' 1"	13' 2"	11' 2"	14' 3"	12' 5"	10' 6"	13' 6"	11' 10"	9' 11"	12' 11"	11' 4"	9' 6"
	16	16' 3"	14' 3"	12' 0"	14' 10"	12' 11"	10' 11"	13' 9"	12' 0"	10' 1"	12' 11"	11' 4"	9' 6"	12' 3"	10' 9"	9' 1"	11' 9"	10' 3"	8' 8"
	24	14' 3"	12' 5"	10' 6"	12' 11"	11' 4"	9' 6"	12' 0"	10' 6"	8' 10"	11' 4"	9' 10"	8' 4"	10' 9"	9' 4"	7' 11"	10' 3"	9' 0"	7' 7"
362S137-97	12	19' 9"	17' 3"	14' 6"	17' 11"	15' 8"	13' 2"	16' 8"	14' 6"	12' 3"	15' 8"	13' 8"	11' 6"	14' 10"	13' 0"	11' 0"	14' 3"	12' 5"	10' 6"
	16	17' 11"	15' 8"	13' 2"	16' 3"	14' 3"	12' 0"	15' 1"	13' 2"	11' 2"	14' 3"	12' 5"	10' 6"	13' 6"	11' 10"	9' 11"	12' 11"	11' 3"	9' 6"
	24	15' 8"	13' 8"	11' 6"	14' 3"	12' 5"	10' 6"	13' 2"	11' 6"	9' 9"	12' 5"	10' 10"	9' 2"	11' 10"	10' 4"	8' 8"	11' 3"	9' 10"	8' 4"
362S162-33	12	15' 1"	13' 2"	11' 1"	13' 2"	12' 0"	10' 1"	11' 10"	11' 1"	9' 5"	10' 9"	10' 6"	8' 10"	10' 0" e	9' 11" e	8' 5"	9' 4" e	9' 4" e	8' 0"
	16	13' 2"	12' 0"	10' 1"	11' 5"	10' 11"	9' 2"	10' 3" e	10' 1" e	8' 6"	9' 4" e	9' 4" e	8' 0"	8' 8" e	8' 8" e	7' 7" e	8' 1" e	8' 1" e	7' 3" e
	24	10' 9"	10' 6"	8' 10"	9' 4" e	9' 4" e	8' 0"	8' 4" e	8' 4" e	7' 5" e	7' 7" e	7' 7" e	7' 0" e	7' 1" e	7' 1" e	6' 8" e	6' 7" e	6' 7" e	6' 4" e
362S162-43	12	16' 5"	14' 4"	12' 1"	14' 11"	13' 0"	11' 0"	13' 10"	12' 1"	10' 2"	12' 9"	11' 5"	9' 7"	11' 10"	10' 10"	9' 1"	11' 1"	10' 4"	8' 9"
	16	14' 11"	13' 0"	11' 0"	13' 6"	11' 10"	10' 0"	12' 1"	11' 0"	9' 3"	11' 1"	10' 4"	8' 9"	10' 3"	9' 10"	8' 3"	9' 7"	9' 5"	7' 11"
	24	12' 9"	11' 5"	9' 7"	11' 1"	10' 4"	8' 9"	9' 11"	9' 7"	8' 1"	9' 0"	9' 0"	7' 7"	8' 4" e	8' 4" e	7' 3"	7' 10" e	7' 10" e	6' 11" e
362S162-54	12	17' 7"	15' 4"	13' 0"	16' 0"	14' 0"	11' 9"	14' 10"	13' 0"	10' 11"	14' 0"	12' 2"	10' 3"	13' 3"	11' 7"	9' 9"	12' 8"	11' 1"	9' 4"
	16	16' 0"	14' 0"	11' 9"	14' 6"	12' 8"	10' 8"	13' 6"	11' 9"	9' 11"	12' 8"	11' 1"	9' 4"	12' 1"	10' 6"	8' 11"	11' 6"	10' 1"	8' 6"
	24	14' 0"	12' 2"	10' 3"	12' 8"	11' 1"	9' 4"	11' 9"	10' 3"	8' 8"	11' 1"	9' 8"	8' 2"	10' 6"	9' 2"	7' 9"	10' 1"	8' 10"	7' 5"
362S162-68	12	18' 10"	16' 5"	13' 10"	17' 1"	14' 11"	12' 7"	15' 11"	13' 10"	11' 8"	14' 11"	13' 1"	11' 0"	14' 2"	12' 5"	10' 6"	13' 7"	11' 10"	10' 0"
	16	17' 1"	14' 11"	12' 7"	15' 6"	13' 7"	11' 5"	14' 5"	12' 7"	10' 8"	13' 7"	11' 10"	10' 0"	12' 11"	11' 3"	9' 6"	12' 4"	10' 9"	9' 1"
	24	14' 11"	13' 1"	11' 0"	13' 7"	11' 10"	10' 0"	12' 7"	11' 0"	9' 3"	11' 10"	10' 4"	8' 9"	11' 3"	9' 10"	8' 4"	10' 9"	9' 5"	7' 11"
362S162-97	12	20' 9"	18' 2"	15' 4"	18' 10"	16' 6"	13' 11"	17' 6"	15' 4"	12' 11"	16' 6"	14' 5"	12' 2"	15' 8"	13' 8"	11' 6"	15' 0"	13' 1"	11' 0"
	16	18' 10"	16' 6"	13' 11"	17' 2"	15' 0"	12' 8"	15' 11"	13' 11"	11' 9"	15' 0"	13' 1"	11' 0"	14' 3"	12' 5"	10' 6"	13' 7"	11' 11"	10' 0"
	24	16' 6"	14' 5"	12' 2"	15' 0"	13' 1"	11' 0"	13' 11"	12' 2"	10' 3"	13' 1"	11' 5"	9' 8"	12' 5"	10' 10"	9' 2"	11' 11"	10' 5"	8' 9"

See page 27 for clarification of code developed wind pressures prior to using this table.

Notes:

- 1 Studs are checked for simple-span deflection and stress. Stress calculations are made for mid-span fully braced moment, end shear through the unperforated section and shear moment interaction through the perforated section 10' away from the end bearing.
- 2 A 1/3 stress increase is not used.
- 3 Limiting heights are based on continuous lateral support of each flange over the full height of the stud.
- 4 Listed limiting heights are based on steel properties only.
- 5 For bending, studs are assumed to be adequately braced to develop full allowable moment capacity. Stud distortional buckling based on an assumed $K\phi = 0$.
- 6 Web crippling check based on 1-inch end bearing. Web stiffeners are required when listed limiting heights are followed by "e".
- 7 Members marked with an ¹ have $h/t > 200$, and thus require end stiffeners.
- 8 Capacities are calculated according to the AISI S100-16 (2020) w/S2-20. A 1-1/2" by 4" knockout spaced no closer than 24" o.c. is assumed. (3/4" for 2-1/2" studs)
- 9 All values are based on $F_y=33\text{ksi}$ for 33mil and 43mil Studs, and $F_y=50\text{ksi}$ for 54mil, 68mil and 97mil Studs.
- 10 For deflection calculations, 15psf and higher wind pressures have been multiplied by 0.7, in accordance with footnote "f" of IBC table 1604.3. The 5 psf pressure has not been reduced for deflection checks.
- 11 Lateral loads have not been modified for strength checks. Full loads are applied.
- 12 End reactions must be checked for web crippling separately.

Complies with AISI S100-16 (2020) w/S2-20 • IBC 2024

CURTAIN WALL HEIGHTS

Member	Spacing (in) o.c.	15psf			20psf			25psf			30psf			35psf			40psf		
		L/240	L/360	L/600	L/240	L/360	L/600	L/240	L/360	L/600	L/240	L/360	L/600	L/240	L/360	L/600	L/240	L/360	L/600
362S200-33	12	15' 11"	13' 11"	11' 8"	13' 11"	12' 7"	10' 8"	12' 5"	11' 8"	9' 10"	11' 4" e	11' 0" e	9' 3"	10' 6" e	10' 6" e	8' 10"	9' 10" e	9' 10" e	8' 5" e
	16	13' 11"	12' 7"	10' 8"	12' 1"	11' 5"	9' 8"	10' 9" e	10' 8" e	9' 0"	9' 10" e	9' 10" e	8' 5" e	9' 1" e	9' 1" e	8' 0" e	8' 6" e	8' 6" e	7' 8" e
	24	11' 4" e	11' 0" e	9' 3"	9' 10" e	9' 10" e	8' 5" e	8' 10" e	8' 10" e	7' 10" e	8' 0" e	8' 0" e	7' 4" e	7' 5" e	7' 5" e	7' 0" e	7' 0" e	7' 0" e	6' 8" e
362S200-43	12	17' 4"	15' 2"	12' 9"	15' 9"	13' 9"	11' 7"	14' 8"	12' 9"	10' 9"	13' 8"	12' 0"	10' 2"	12' 8"	11' 5"	9' 8"	11' 10"	10' 11"	9' 3"
	16	15' 9"	13' 9"	11' 7"	14' 4"	12' 6"	10' 7"	13' 0"	11' 7"	9' 10"	11' 10"	10' 11"	9' 3"	11' 0"	10' 5"	8' 9"	10' 3"	9' 11"	8' 4"
	24	13' 8"	12' 0"	10' 2"	11' 10"	10' 11"	9' 3"	10' 7"	10' 2"	8' 7"	9' 8" e	9' 7" e	8' 1"	8' 11" e	8' 11" e	7' 8"	8' 5" e	8' 5" e	7' 4" e
362S200-54	12	18' 7"	16' 3"	13' 8"	16' 11"	14' 9"	12' 5"	15' 8"	13' 8"	11' 7"	14' 9"	12' 11"	10' 11"	14' 0"	12' 3"	10' 4"	13' 5"	11' 9"	9' 11"
	16	16' 11"	14' 9"	12' 5"	15' 4"	13' 5"	11' 4"	14' 3"	12' 5"	10' 6"	13' 5"	11' 9"	9' 11"	12' 9"	11' 2"	9' 5"	12' 2"	10' 8"	9' 0"
	24	14' 9"	12' 11"	10' 11"	13' 5"	11' 9"	9' 11"	12' 5"	10' 11"	9' 2"	11' 9"	10' 3"	8' 8"	11' 2"	9' 9"	8' 2"	10' 8"	9' 4"	7' 10"
362S200-68	12	19' 11"	17' 5"	14' 8"	18' 1"	15' 10"	13' 4"	16' 10"	14' 8"	12' 5"	15' 10"	13' 10"	11' 8"	15' 0"	13' 1"	11' 1"	14' 4"	12' 7"	10' 7"
	16	18' 1"	15' 10"	13' 4"	16' 5"	14' 4"	12' 1"	15' 3"	13' 4"	11' 3"	14' 4"	12' 7"	10' 7"	13' 8"	11' 11"	10' 1"	13' 1"	11' 5"	9' 7"
	24	15' 10"	13' 10"	11' 8"	14' 4"	12' 7"	10' 7"	13' 4"	11' 8"	9' 10"	12' 7"	11' 0"	9' 3"	11' 11"	10' 5"	8' 9"	11' 5"	10' 0"	8' 5"
362S200-97	12	22' 0"	19' 3"	16' 3"	20' 0"	17' 6"	14' 9"	18' 7"	16' 3"	13' 8"	17' 6"	15' 3"	12' 11"	16' 7"	14' 6"	12' 3"	15' 11"	13' 11"	11' 8"
	16	20' 0"	17' 6"	14' 9"	18' 2"	15' 11"	13' 5"	16' 11"	14' 9"	12' 5"	15' 11"	13' 11"	11' 8"	15' 1"	13' 2"	11' 1"	14' 5"	12' 7"	10' 8"
	24	17' 6"	15' 3"	12' 11"	15' 11"	13' 11"	11' 8"	14' 9"	12' 11"	10' 10"	13' 11"	12' 1"	10' 3"	13' 2"	11' 6"	9' 9"	12' 7"	11' 0"	9' 3"
362S250-43	12	18' 4"	16' 0"	13' 6"	16' 7"	14' 6"	12' 3"	15' 5"	13' 6"	11' 4"	14' 2"	12' 8"	10' 8"	13' 1"	12' 1"	10' 2"	12' 3"	11' 6"	9' 9"
	16	16' 7"	14' 6"	12' 3"	15' 0"	13' 2"	11' 2"	13' 5"	12' 3"	10' 4"	12' 3"	11' 6"	9' 9"	11' 4"	10' 11"	9' 3"	10' 8" e	10' 6" e	8' 10"
	24	14' 2"	12' 8"	10' 8"	12' 3"	11' 6"	9' 9"	11' 0"	10' 8"	9' 0"	10' 0" e	10' 0" e	8' 6"	9' 3" e	9' 3" e	8' 1" e	8' 8" e	8' 8" e	7' 9" e
362S250-54	12	19' 7"	17' 1"	14' 5"	17' 9"	15' 6"	13' 1"	16' 6"	14' 5"	12' 2"	15' 6"	13' 7"	11' 5"	14' 9"	12' 11"	10' 10"	14' 1"	12' 4"	10' 5"
	16	17' 9"	15' 6"	13' 1"	16' 2"	14' 1"	11' 11"	15' 0"	13' 1"	11' 1"	14' 1"	12' 4"	10' 5"	13' 5"	11' 8"	9' 10"	12' 10"	11' 2"	9' 5"
	24	15' 6"	13' 7"	11' 5"	14' 1"	12' 4"	10' 5"	13' 1"	11' 5"	9' 8"	12' 4"	10' 9"	9' 1"	11' 8"	10' 3"	8' 7"	11' 2"	9' 9"	8' 3"
362S250-68	12	21' 0"	18' 5"	15' 6"	19' 1"	16' 8"	14' 1"	17' 9"	15' 6"	13' 1"	16' 8"	14' 7"	12' 4"	15' 10"	13' 10"	11' 8"	15' 2"	13' 3"	11' 2"
	16	19' 1"	16' 8"	14' 1"	17' 4"	15' 2"	12' 10"	16' 1"	14' 1"	11' 11"	15' 2"	13' 3"	11' 2"	14' 5"	12' 7"	10' 7"	13' 9"	12' 0"	10' 2"
	24	16' 8"	14' 7"	12' 4"	15' 2"	13' 3"	11' 2"	14' 1"	12' 4"	10' 5"	13' 3"	11' 7"	9' 9"	12' 7"	11' 0"	9' 3"	12' 0"	10' 6"	8' 10"
362S250-97	12	23' 4"	20' 4"	17' 2"	21' 2"	18' 6"	15' 7"	19' 8"	17' 2"	14' 6"	18' 6"	16' 2"	13' 8"	17' 7"	15' 4"	12' 11"	16' 10"	14' 8"	12' 5"
	16	21' 2"	18' 6"	15' 7"	19' 3"	16' 10"	14' 2"	17' 10"	15' 7"	13' 2"	16' 10"	14' 8"	12' 5"	16' 0"	13' 11"	11' 9"	15' 3"	13' 4"	11' 3"
	24	18' 6"	16' 2"	13' 8"	16' 10"	14' 8"	12' 5"	15' 7"	13' 8"	11' 6"	14' 8"	12' 10"	10' 10"	13' 11"	12' 2"	10' 3"	13' 4"	11' 8"	9' 10"

See page 27 for clarification of code developed wind pressures prior to using this table.

Notes:

- 1 Studs are checked for simple-span deflection and stress. Stress calculations are made for mid-span fully braced moment, end shear through the unperforated section and shear moment interaction through the perforated section 10" away from the end bearing.
- 2 A 1/3 stress increase is not used.
- 3 Limiting heights are based on continuous lateral support of each flange over the full height of the stud.
- 4 Listed limiting heights are based on steel properties only.
- 5 For bending, studs are assumed to be adequately braced to develop full allowable moment capacity. Stud distortional buckling based on an assumed $K\phi = 0$.
- 6 Web crippling check based on 1-inch end bearing. Web stiffeners are required when listed limiting heights are followed by "e".
- 7 Members marked with an ¹ have $h/t > 200$, and thus require end stiffeners.
- 8 Capacities are calculated according to the AISI S100-16 (2020) w/S2-20. A 1-1/2" by 4" knockout spaced no closer than 24" o.c. is assumed. (3/4" for 2-1/2" studs)
- 9 All values are based on $F_y=33$ ksi for 33mil and 43mil Studs, and $F_y=50$ ksi for 54mil, 68mil and 97mil Studs.
- 10 For deflection calculations, 15psf and higher wind pressures have been multiplied by 0.7, in accordance with footnote "f" of IBC table 1604.3. The 5 psf pressure has not been reduced for deflection checks.
- 11 Lateral loads have not been modified for strength checks. Full loads are applied.
- 12 End reactions must be checked for web crippling separately.

Complies with AISI S100-16 (2020) w/S2-20 • IBC 2024

CURTAIN WALL HEIGHTS

Member	Spacing (in) o.c.	15psf			20psf			25psf			30psf			35psf			40psf		
		L/240	L/360	L/600	L/240	L/360	L/600	L/240	L/360	L/600	L/240	L/360	L/600	L/240	L/360	L/600	L/240	L/360	L/600
400S137-33	12	14' 11"	13' 7"	11' 6"	12' 11"	12' 4"	10' 5"	11' 7"	11' 6"	9' 8"	10' 7"	10' 7"	9' 1"	9' 9" e	9' 9" e	8' 8"	9' 2" e	9' 2" e	8' 3" e
	16	12' 11"	12' 4"	10' 5"	11' 2"	11' 2"	9' 6"	10' 0" e	10' 0" e	8' 9"	9' 2" e	9' 2" e	8' 3" e	8' 6" e	8' 6" e	7' 10" e	7' 11" e	7' 11" e	7' 6" e
	24	10' 7"	10' 7"	9' 1"	9' 2" e	9' 2" e	8' 3" e	8' 2" e	8' 2" e	7' 8" e	7' 6" e	7' 6" e	6' 11" e	6' 11" e	6' 10" e	6' 6" e	6' 6" e	6' 6" e	6' 6" e
400S137-43	12	16' 11"	14' 9"	12' 6"	15' 4"	13' 5"	11' 4"	13' 9"	12' 6"	10' 6"	12' 7"	11' 9"	9' 11"	11' 7"	11' 2"	9' 5"	10' 10"	10' 8"	9' 0"
	16	15' 4"	13' 5"	11' 4"	13' 4"	12' 2"	10' 4"	11' 11"	11' 4"	9' 7"	10' 10"	10' 8"	9' 0"	10' 1"	10' 1"	8' 6"	9' 5"	9' 5"	8' 2"
	24	12' 7"	11' 9"	9' 11"	10' 10"	10' 8"	9' 0"	9' 9"	8' 4"	8' 10"	8' 10"	7' 10"	8' 3" e	8' 3" e	7' 6"	7' 8" e	7' 8" e	7' 2" e	
400S137-54	12	18' 1"	15' 10"	13' 4"	16' 6"	14' 5"	12' 2"	15' 3"	13' 4"	11' 3"	14' 5"	12' 7"	10' 7"	13' 8"	11' 11"	10' 1"	13' 1"	11' 5"	9' 8"
	16	16' 6"	14' 5"	12' 2"	15' 0"	13' 1"	11' 0"	13' 11"	12' 2"	10' 3"	13' 1"	11' 5"	9' 8"	12' 5"	10' 10"	9' 2"	11' 10"	10' 4"	8' 9"
	24	14' 5"	12' 7"	10' 7"	13' 1"	11' 5"	9' 8"	12' 2"	10' 7"	8' 11"	11' 5"	10' 0"	8' 5"	10' 10"	9' 6"	8' 0"	10' 3"	9' 1"	7' 8"
400S137-68	12	19' 5"	16' 11"	14' 3"	17' 7"	15' 5"	13' 0"	16' 4"	14' 3"	12' 0"	15' 5"	13' 5"	11' 4"	14' 7"	12' 9"	10' 9"	14' 0"	12' 2"	10' 4"
	16	17' 7"	15' 5"	13' 0"	16' 0"	14' 0"	11' 9"	14' 10"	13' 0"	10' 11"	14' 0"	12' 2"	10' 4"	13' 3"	11' 7"	9' 9"	12' 8"	11' 1"	9' 4"
	24	15' 5"	13' 5"	11' 4"	14' 0"	12' 2"	10' 4"	13' 0"	11' 4"	9' 7"	12' 2"	10' 8"	9' 0"	11' 7"	10' 2"	8' 7"	11' 1"	9' 8"	8' 2"
400S137-97	12	21' 4"	18' 8"	15' 9"	19' 5"	16' 11"	14' 3"	18' 0"	15' 9"	13' 3"	16' 11"	14' 10"	12' 6"	16' 1"	14' 1"	11' 10"	15' 5"	13' 5"	11' 4"
	16	19' 5"	16' 11"	14' 3"	17' 7"	15' 5"	13' 0"	16' 4"	14' 3"	12' 1"	15' 5"	13' 5"	11' 4"	14' 7"	12' 9"	10' 9"	14' 0"	12' 3"	10' 4"
	24	16' 11"	14' 10"	12' 6"	15' 5"	13' 5"	11' 4"	14' 3"	12' 6"	10' 6"	13' 5"	11' 9"	9' 11"	12' 9"	11' 2"	9' 5"	12' 3"	10' 8"	9' 0"
400S162-33	12	16' 1"	14' 3"	12' 0"	13' 11"	12' 11"	10' 11"	12' 6"	12' 0"	10' 1"	11' 5" e	11' 4" e	9' 6"	10' 6" e	10' 6" e	9' 1"	9' 10" e	9' 10" e	8' 8" e
	16	13' 11"	12' 11"	10' 11"	12' 1"	11' 9"	9' 11"	10' 10" e	10' 10" e	9' 2"	9' 10" e	9' 10" e	8' 8" e	9' 2" e	9' 2" e	8' 3" e	8' 6" e	8' 6" e	7' 10" e
	24	11' 5" e	11' 4" e	9' 6"	9' 10" e	9' 10" e	8' 8" e	8' 10" e	8' 10" e	8' 0" e	8' 1" e	8' 1" e	7' 7" e	7' 5" e	7' 5" e	7' 2" e	7' 0" e	7' 0" e	6' 10" e
400S162-43	12	17' 9"	15' 6"	13' 1"	16' 1"	14' 1"	11' 10"	14' 10"	13' 1"	11' 0"	13' 6"	12' 3"	10' 4"	12' 6"	11' 8"	9' 10"	11' 8"	11' 2"	9' 5"
	16	16' 1"	14' 1"	11' 10"	14' 4"	12' 9"	10' 9"	12' 10"	11' 10"	10' 0"	11' 8"	11' 2"	9' 5"	10' 10"	10' 7"	8' 11"	10' 2"	10' 2"	8' 7"
	24	13' 6"	12' 3"	10' 4"	11' 8"	11' 2"	9' 5"	10' 6"	10' 4"	8' 9"	9' 7" e	9' 7" e	8' 3"	8' 10" e	8' 10" e	7' 10"	8' 3" e	8' 3" e	7' 6" e
400S162-54	12	19' 0"	16' 7"	14' 0"	17' 3"	15' 1"	12' 9"	16' 0"	14' 0"	11' 10"	15' 1"	13' 2"	11' 1"	14' 4"	12' 6"	10' 7"	13' 8"	12' 0"	10' 1"
	16	17' 3"	15' 1"	12' 9"	15' 8"	13' 8"	11' 7"	14' 7"	12' 9"	10' 9"	13' 8"	12' 0"	10' 1"	13' 0"	11' 4"	9' 7"	12' 5"	10' 10"	9' 2"
	24	15' 1"	13' 2"	11' 1"	13' 8"	12' 0"	10' 1"	12' 9"	11' 1"	9' 4"	12' 0"	10' 5"	8' 10"	11' 4"	9' 11"	8' 5"	10' 10"	9' 6"	8' 0"
400S162-68	12	20' 4"	17' 9"	15' 0"	18' 6"	16' 2"	13' 7"	17' 2"	15' 0"	12' 8"	16' 2"	14' 1"	11' 11"	15' 4"	13' 5"	11' 4"	14' 8"	12' 10"	10' 10"
	16	18' 6"	16' 2"	13' 7"	16' 9"	14' 8"	12' 4"	15' 7"	13' 7"	11' 6"	14' 8"	12' 10"	10' 10"	13' 11"	12' 2"	10' 3"	13' 4"	11' 8"	9' 10"
	24	16' 2"	14' 1"	11' 11"	14' 8"	12' 10"	10' 10"	13' 7"	11' 11"	10' 0"	12' 10"	11' 2"	9' 5"	12' 2"	10' 8"	9' 0"	11' 8"	10' 2"	8' 7"
400S162-97	12	22' 5"	19' 7"	16' 7"	20' 5"	17' 10"	15' 0"	18' 11"	16' 7"	13' 11"	17' 10"	15' 7"	13' 2"	16' 11"	14' 9"	12' 6"	16' 2"	14' 2"	11' 11"
	16	20' 5"	17' 10"	15' 0"	18' 6"	16' 2"	13' 8"	17' 2"	15' 0"	12' 8"	16' 2"	14' 2"	11' 11"	15' 5"	13' 5"	11' 4"	14' 9"	12' 10"	10' 10"
	24	17' 10"	15' 7"	13' 2"	16' 2"	14' 2"	11' 11"	15' 0"	13' 2"	11' 1"	14' 2"	12' 4"	10' 5"	13' 5"	11' 9"	9' 11"	12' 10"	11' 3"	9' 6"

See page 27 for clarification of code developed wind pressures prior to using this table.

Notes:

- 1 Studs are checked for simple-span deflection and stress. Stress calculations are made for mid-span fully braced moment, end shear through the unperforated section and shear moment interaction through the perforated section 10' away from the end bearing.
- 2 A 1/3 stress increase is not used.
- 3 Limiting heights are based on continuous lateral support of each flange over the full height of the stud.
- 4 Listed limiting heights are based on steel properties only.
- 5 For bending, studs are assumed to be adequately braced to develop full allowable moment capacity. Stud distortional buckling based on an assumed $K\phi = 0$.
- 6 Web crippling check based on 1-inch end bearing. Web stiffeners are required when listed limiting heights are followed by "e".
- 7 Members marked with an ¹ have $h/t > 200$, and thus require end stiffeners.
- 8 Capacities are calculated according to the AISI S100-16 (2020) w/S2-20. A 1-1/2" by 4" knockout spaced no closer than 24" o.c. is assumed. (3/4" for 2-1/2" studs)
- 9 All values are based on $F_y=33$ ksi for 33mil and 43mil Studs, and $F_y=50$ ksi for 54mil, 68mil and 97mil Studs.
- 10 For deflection calculations, 15psf and higher wind pressures have been multiplied by 0.7, in accordance with footnote "f" of IBC table 1604.3. The 5 psf pressure has not been reduced for deflection checks.
- 11 Lateral loads have not been modified for strength checks. Full loads are applied.
- 12 End reactions must be checked for web crippling separately.

Complies with AISI S100-16 (2020) w/S2-20 • IBC 2024

CURTAIN WALL HEIGHTS

Member	Spacing (in) o.c.	15psf			20psf			25psf			30psf			35psf			40psf		
		L/240	L/360	L/600	L/240	L/360	L/600	L/240	L/360	L/600	L/240	L/360	L/600	L/240	L/360	L/600	L/240	L/360	L/600
400S200-33	12	17' 0"	15' 0"	12' 7"	14' 9"	13' 7"	11' 6"	13' 2" e	12' 7"	10' 8"	12' 0" e	11' 10" e	10' 0"	11' 1" e	11' 1" e	9' 6" e	10' 5" e	10' 5" e	9' 1" e
	16	14' 9"	13' 7"	11' 6"	12' 9" e	12' 4" e	10' 5"	11' 5" e	11' 5" e	9' 8"	10' 5" e	10' 5" e	9' 1" e	9' 8" e	9' 8" e	8' 8" e	9' 0" e	9' 0" e	8' 3" e
	24	12' 0" e	11' 10" e	10' 0"	10' 5" e	10' 5" e	9' 1" e	9' 4" e	9' 4" e	8' 5" e	8' 6" e	8' 6" e	7' 11" e	7' 10" e	7' 10" e	7' 7" e	7' 4" e	7' 4" e	7' 3" e
400S200-43	12	18' 8"	16' 4"	13' 9"	17' 0"	14' 10"	12' 6"	15' 9"	13' 9"	11' 7"	14' 6"	13' 0"	10' 11"	13' 5"	12' 4"	10' 5"	12' 6"	11' 9"	9' 11"
	16	17' 0"	14' 10"	12' 6"	15' 4"	13' 6"	11' 4"	13' 9"	12' 6"	10' 7"	12' 6"	11' 9"	9' 11"	11' 7"	11' 2"	9' 5"	10' 10" e	10' 8" e	9' 0"
	24	14' 6"	13' 0"	10' 11"	12' 6"	11' 9"	9' 11"	11' 3" e	10' 11"	9' 3"	10' 3" e	10' 3" e	8' 8"	9' 6" e	9' 6" e	8' 3" e	8' 10" e	8' 10" e	7' 11" e
400S200-54	12	20' 1"	17' 6"	14' 9"	18' 3"	15' 11"	13' 5"	16' 11"	14' 9"	12' 6"	15' 11"	13' 11"	11' 9"	15' 1"	13' 3"	11' 2"	14' 6"	12' 8"	10' 8"
	16	18' 3"	15' 11"	13' 5"	16' 7"	14' 6"	12' 2"	15' 4"	13' 5"	11' 4"	14' 6"	12' 8"	10' 8"	13' 9"	12' 0"	10' 1"	13' 2"	11' 6"	9' 8"
	24	15' 11"	13' 11"	11' 9"	14' 6"	12' 8"	10' 8"	13' 5"	11' 9"	9' 11"	12' 8"	11' 0"	9' 4"	12' 0"	10' 6"	8' 10"	11' 6"	10' 0"	8' 5"
400S200-68	12	21' 6"	18' 9"	15' 10"	19' 6"	17' 1"	14' 5"	18' 1"	15' 10"	13' 4"	17' 1"	14' 11"	12' 7"	16' 2"	14' 2"	11' 11"	15' 6"	13' 6"	11' 5"
	16	19' 6"	17' 1"	14' 5"	17' 9"	15' 6"	13' 1"	16' 6"	14' 5"	12' 2"	15' 6"	13' 6"	11' 5"	14' 9"	12' 10"	10' 10"	14' 1"	12' 4"	10' 4"
	24	17' 1"	14' 11"	12' 7"	15' 6"	13' 6"	11' 5"	14' 5"	12' 7"	10' 7"	13' 6"	11' 10"	10' 0"	12' 10"	11' 3"	9' 6"	12' 4"	10' 9"	9' 1"
400S200-97	12	23' 9"	20' 9"	17' 6"	21' 7"	18' 11"	15' 11"	20' 1"	17' 6"	14' 9"	18' 11"	16' 6"	13' 11"	17' 11"	15' 8"	13' 3"	17' 2"	15' 0"	12' 8"
	16	21' 7"	18' 11"	15' 11"	19' 8"	17' 2"	14' 6"	18' 3"	15' 11"	13' 5"	17' 2"	15' 0"	12' 8"	16' 4"	14' 3"	12' 0"	15' 7"	13' 7"	11' 6"
	24	18' 11"	16' 6"	13' 11"	17' 2"	15' 0"	12' 8"	15' 11"	13' 11"	11' 9"	15' 0"	13' 1"	11' 0"	14' 3"	12' 5"	10' 6"	13' 7"	11' 11"	10' 0"
400S250-43	12	19' 8"	17' 2"	14' 6"	17' 11"	15' 8"	13' 2"	16' 5"	14' 6"	12' 3"	15' 0"	13' 8"	11' 6"	13' 10"	13' 0"	10' 11"	13' 0"	12' 5"	10' 6"
	16	17' 11"	15' 8"	13' 2"	15' 11"	14' 2"	12' 0"	14' 2"	13' 2"	11' 1"	13' 0"	12' 5"	10' 6"	12' 0" e	11' 9" e	9' 11"	11' 3" e	11' 3" e	9' 6"
	24	15' 0"	13' 8"	11' 6"	13' 0"	12' 5"	10' 6"	11' 7" e	11' 6" e	9' 9"	10' 7" e	10' 7" e	9' 2" e	9' 10" e	9' 10" e	8' 8" e	9' 2" e	9' 2" e	8' 4" e
400S250-54	12	21' 1"	18' 5"	15' 6"	19' 2"	16' 9"	14' 1"	17' 9"	15' 6"	13' 1"	16' 9"	14' 7"	12' 4"	15' 11"	13' 10"	11' 8"	15' 2"	13' 3"	11' 2"
	16	19' 2"	16' 9"	14' 1"	17' 5"	15' 2"	12' 10"	16' 2"	14' 1"	11' 11"	15' 2"	13' 3"	11' 2"	14' 5"	12' 7"	10' 8"	13' 10"	12' 1"	10' 2"
	24	16' 9"	14' 7"	12' 4"	15' 2"	13' 3"	11' 2"	14' 1"	12' 4"	10' 5"	13' 3"	11' 7"	9' 9"	12' 7"	11' 0"	9' 3"	12' 1"	10' 6"	8' 11"
400S250-68	12	22' 8"	19' 10"	16' 8"	20' 7"	18' 0"	15' 2"	19' 1"	16' 8"	14' 1"	18' 0"	15' 9"	13' 3"	17' 1"	14' 11"	12' 7"	16' 4"	14' 3"	12' 1"
	16	20' 7"	18' 0"	15' 2"	18' 9"	16' 4"	13' 9"	17' 4"	15' 2"	12' 10"	16' 4"	14' 3"	12' 1"	15' 6"	13' 7"	11' 5"	14' 10"	13' 0"	10' 11"
	24	18' 0"	15' 9"	13' 3"	16' 4"	14' 3"	12' 1"	15' 2"	13' 3"	11' 2"	14' 3"	12' 6"	10' 6"	13' 7"	11' 10"	10' 0"	13' 0"	11' 4"	9' 7"
400S250-97	12	25' 2"	21' 11"	18' 6"	22' 10"	19' 11"	16' 10"	21' 2"	18' 6"	15' 7"	19' 11"	17' 5"	14' 8"	18' 11"	16' 7"	14' 0"	18' 1"	15' 10"	13' 4"
	16	22' 10"	19' 11"	16' 10"	20' 9"	18' 1"	15' 3"	19' 3"	16' 10"	14' 2"	18' 1"	15' 10"	13' 4"	17' 3"	15' 0"	12' 8"	16' 6"	14' 5"	12' 2"
	24	19' 11"	17' 5"	14' 8"	18' 1"	15' 10"	13' 4"	16' 10"	14' 8"	12' 5"	15' 10"	13' 10"	11' 8"	15' 0"	13' 2"	11' 1"	14' 5"	12' 7"	10' 7"

See page 27 for clarification of code developed wind pressures prior to using this table.

Notes:

- 1 Studs are checked for simple-span deflection and stress. Stress calculations are made for mid-span fully braced moment, end shear through the unperforated section and shear moment interaction through the perforated section 10" away from the end bearing.
- 2 A 1/3 stress increase is not used.
- 3 Limiting heights are based on continuous lateral support of each flange over the full height of the stud.
- 4 Listed limiting heights are based on steel properties only.
- 5 For bending, studs are assumed to be adequately braced to develop full allowable moment capacity. Stud distortional buckling based on an assumed $K\phi = 0$.
- 6 Web crippling check based on 1-inch end bearing. Web stiffeners are required when listed limiting heights are followed by "e".
- 7 Members marked with an ¹ have h/t > 200, and thus require end stiffeners.
- 8 Capacities are calculated according to the AISI S100-16 (2020) w/S2-20. A 1-1/2" by 4" knockout spaced no closer than 24" o.c. is assumed. (3/4" for 2-1/2" studs)
- 9 All values are based on Fy=33ksi for 33mil and 43mil Studs, and Fy=50ksi for 54mil, 68mil and 97mil Studs.
- 10 For deflection calculations, 15psf and higher wind pressures have been multiplied by 0.7, in accordance with footnote "f" of IBC table 1604.3. The 5 psf pressure has not been reduced for deflection checks.
- 11 Lateral loads have not been modified for strength checks. Full loads are applied.
- 12 End reactions must be checked for web crippling separately.

Complies with AISI S100-16 (2020) w/S2-20 • IBC 2024

CURTAIN WALL HEIGHTS

Member	Spacing (in) o.c.	15psf			20psf			25psf			30psf			35psf			40psf		
		L/240	L/360	L/600	L/240	L/360	L/600	L/240	L/360	L/600	L/240	L/360	L/600	L/240	L/360	L/600	L/240	L/360	L/600
600S137-33	12	18' 8"	18' 7"	15' 8"	16' 2" e	16' 2" e	14' 3"	14' 5" e	14' 5" e	13' 3" e	13' 2" e	13' 2" e	12' 5" e	12' 2" e	12' 2" e	11' 10" e	11' 5" e	11' 5" e	11' 4" e
	16	16' 2" e	16' 2" e	14' 3"	14' 0" e	14' 0" e	12' 11" e	12' 6" e	12' 6" e	12' 0" e	11' 5" e	11' 5" e	11' 4" e	10' 7" e	10' 7" e	10' 7" e	9' 11" e	9' 11" e	9' 11" e
	24	13' 2" e	13' 2" e	12' 5" e	11' 5" e	11' 5" e	11' 4" e	10' 2" e	10' 2" e	10' 2" e	9' 4" e	9' 4" e	9' 4" e	8' 8" e	8' 8" e	8' 8" e	8' 1" e	8' 1" e	8' 1" e
600S137-43	12	22' 4"	20' 5"	17' 3"	19' 4"	18' 6"	15' 8"	17' 4"	17' 3"	14' 6"	15' 10"	15' 10"	13' 8"	14' 8"	14' 8"	13' 0"	13' 8" e	13' 8" e	12' 5"
	16	19' 4"	18' 6"	15' 8"	16' 9"	16' 9"	14' 2"	15' 0"	15' 0"	13' 2"	13' 8" e	13' 8" e	12' 5"	12' 8" e	12' 8" e	11' 9" e	11' 10" e	11' 10" e	11' 3" e
	24	15' 10"	15' 10"	13' 8"	13' 8" e	13' 8" e	12' 5"	12' 3" e	12' 3" e	11' 6" e	11' 2" e	11' 2" e	10' 10" e	10' 4" e	10' 4" e	10' 4" e	9' 8" e	9' 8" e	9' 8" e
600S137-54	12	25' 1"	21' 11"	18' 5"	22' 9"	19' 11"	16' 9"	21' 2"	18' 5"	15' 7"	19' 11"	17' 4"	14' 8"	18' 11"	16' 6"	13' 11"	18' 1"	15' 9"	13' 4"
	16	22' 9"	19' 11"	16' 9"	20' 8"	18' 1"	15' 3"	19' 2"	16' 9"	14' 2"	18' 1"	15' 9"	13' 4"	16' 11"	15' 0"	12' 8"	15' 10"	14' 4"	12' 1"
	24	19' 11"	17' 4"	14' 8"	18' 1"	15' 9"	13' 4"	16' 4"	14' 8"	12' 4"	14' 11"	13' 9"	11' 8"	13' 10"	13' 1"	11' 1"	12' 11"	12' 6"	10' 7"
600S137-68	12	26' 10"	23' 5"	19' 9"	24' 5"	21' 4"	18' 0"	22' 8"	19' 9"	16' 8"	19' 9"	16' 8"	17' 4"	18' 7"	15' 8"	20' 3"	17' 8"	14' 11"	19' 4"
	16	24' 5"	21' 4"	18' 0"	22' 2"	19' 4"	16' 4"	20' 7"	18' 0"	15' 2"	19' 4"	16' 11"	14' 3"	18' 5"	16' 1"	13' 7"	17' 7"	15' 4"	12' 11"
	24	21' 4"	18' 7"	15' 8"	19' 4"	16' 11"	14' 3"	18' 0"	15' 8"	13' 3"	16' 11"	14' 9"	12' 5"	16' 1"	14' 0"	11' 10"	15' 1"	13' 5"	11' 4"
600S137-97	12	29' 8"	25' 11"	21' 10"	27' 0"	23' 7"	19' 10"	25' 0"	21' 10"	18' 5"	23' 7"	20' 7"	17' 4"	22' 5"	19' 7"	16' 6"	21' 5"	18' 8"	15' 9"
	16	27' 0"	23' 7"	19' 10"	24' 6"	21' 5"	18' 1"	22' 9"	19' 10"	16' 9"	21' 5"	18' 8"	15' 9"	20' 4"	17' 9"	15' 0"	19' 5"	17' 0"	14' 4"
	24	23' 7"	20' 7"	17' 4"	21' 5"	18' 8"	15' 9"	19' 10"	17' 4"	14' 8"	18' 8"	16' 4"	13' 9"	17' 9"	15' 6"	13' 1"	17' 0"	14' 10"	12' 6"
600S162-33	12	20' 2"	19' 6"	16' 6"	17' 5" e	17' 5" e	15' 0"	15' 7" e	15' 7" e	13' 11" e	14' 3" e	14' 3" e	13' 1" e	13' 2" e	13' 2" e	12' 5" e	12' 4" e	12' 4" e	11' 11" e
	16	17' 5" e	17' 5" e	15' 0"	15' 1" e	15' 1" e	13' 7" e	13' 6" e	13' 6" e	12' 8" e	12' 4" e	12' 4" e	11' 11" e	11' 5" e	11' 5" e	11' 3" e	10' 8" e	10' 8" e	10' 8" e
	24	14' 3" e	14' 3" e	13' 1" e	12' 4" e	12' 4" e	11' 11" e	11' 0" e	11' 0" e	11' 0" e	10' 1" e	10' 1" e	10' 1" e	9' 4" e	9' 4" e	9' 4" e	8' 9" e	8' 9" e	8' 9" e
600S162-43	12	24' 1"	21' 3"	17' 11"	20' 10"	19' 4"	16' 4"	18' 8"	17' 11"	15' 2"	17' 0"	16' 11"	14' 3"	15' 9" e	15' 9" e	13' 6"	14' 9" e	14' 9" e	12' 11"
	16	20' 10"	19' 4"	16' 4"	18' 1"	17' 7"	14' 10"	16' 2" e	16' 2" e	13' 9"	14' 9" e	14' 9" e	12' 11"	13' 8" e	13' 8" e	12' 4" e	12' 9" e	12' 9" e	11' 9" e
	24	17' 0"	16' 11"	14' 3"	14' 9" e	14' 9" e	12' 11"	13' 2" e	13' 2" e	12' 0" e	12' 1" e	12' 1" e	11' 4" e	11' 2" e	11' 2" e	10' 9" e	10' 5" e	10' 5" e	10' 3" e
600S162-54	12	26' 2"	22' 10"	19' 3"	23' 9"	20' 9"	17' 6"	22' 1"	19' 3"	16' 3"	20' 9"	18' 1"	15' 3"	19' 8"	17' 3"	14' 6"	18' 10"	16' 6"	13' 11"
	16	23' 9"	20' 9"	17' 6"	21' 7"	18' 10"	15' 11"	20' 0"	17' 6"	14' 9"	18' 10"	16' 6"	13' 11"	17' 11"	15' 8"	13' 2"	17' 0"	15' 0"	12' 7"
	24	20' 9"	18' 1"	15' 3"	18' 10"	16' 6"	13' 11"	17' 6"	15' 3"	12' 11"	16' 1"	14' 5"	12' 2"	14' 10"	13' 8"	11' 6"	13' 11"	13' 1"	11' 0"
600S162-68	12	28' 0"	24' 6"	20' 8"	25' 6"	22' 3"	18' 9"	23' 8"	20' 8"	17' 5"	22' 3"	19' 5"	16' 5"	21' 2"	18' 5"	15' 7"	20' 3"	17' 8"	14' 11"
	16	25' 6"	22' 3"	18' 9"	23' 2"	20' 3"	17' 1"	21' 6"	18' 9"	15' 10"	20' 3"	17' 8"	14' 11"	19' 2"	16' 9"	14' 2"	18' 4"	16' 0"	13' 6"
	24	22' 3"	19' 5"	16' 5"	20' 3"	17' 8"	14' 11"	18' 9"	16' 5"	13' 10"	17' 8"	15' 5"	13' 0"	16' 9"	14' 8"	12' 4"	16' 0"	14' 0"	11' 10"
600S162-97	12	31' 1"	27' 2"	22' 11"	28' 3"	24' 8"	20' 9"	26' 2"	22' 11"	19' 4"	24' 8"	21' 6"	18' 2"	23' 5"	20' 5"	17' 3"	22' 5"	19' 7"	16' 6"
	16	28' 3"	24' 8"	20' 9"	25' 8"	22' 5"	18' 11"	23' 10"	20' 9"	17' 6"	22' 5"	19' 7"	16' 6"	21' 3"	18' 7"	15' 8"	20' 4"	17' 9"	15' 0"
	24	24' 8"	21' 6"	18' 2"	22' 5"	19' 7"	16' 6"	20' 9"	18' 2"	15' 4"	19' 7"	17' 1"	14' 5"	18' 7"	16' 3"	13' 8"	17' 9"	15' 6"	13' 1"

See page 27 for clarification of code developed wind pressures prior to using this table.

Notes:

- 1 Studs are checked for simple-span deflection and stress. Stress calculations are made for mid-span fully braced moment, end shear through the unperforated section and shear moment interaction through the perforated section 10' away from the end bearing.
- 2 A 1/3 stress increase is not used.
- 3 Limiting heights are based on continuous lateral support of each flange over the full height of the stud.
- 4 Listed limiting heights are based on steel properties only.
- 5 For bending, studs are assumed to be adequately braced to develop full allowable moment capacity. Stud distortional buckling based on an assumed $K\phi = 0$.
- 6 Web crippling check based on 1-inch end bearing. Web stiffeners are required when listed limiting heights are followed by "e".
- 7 Members marked with an ¹ have $h/t > 200$, and thus require end stiffeners.
- 8 Capacities are calculated according to the AISI S100-16 (2020) w/S2-20. A 1-1/2" by 4" knockout spaced no closer than 24" o.c. is assumed. (3/4" for 2-1/2" studs)
- 9 All values are based on $F_y=33$ ksi for 33mil and 43mil Studs, and $F_y=50$ ksi for 54mil, 68mil and 97mil Studs.
- 10 For deflection calculations, 15psf and higher wind pressures have been multiplied by 0.7, in accordance with footnote "f" of IBC table 1604.3. The 5 psf pressure has not been reduced for deflection checks.
- 11 Lateral loads have not been modified for strength checks. Full loads are applied.
- 12 End reactions must be checked for web crippling separately.

Complies with AISI S100-16 (2020) w/S2-20 • IBC 2024

CURTAIN WALL HEIGHTS

Member	Spacing (in) o.c.	15psf			20psf			25psf			30psf			35psf			40psf		
		L/240	L/360	L/600	L/240	L/360	L/600	L/240	L/360	L/600	L/240	L/360	L/600	L/240	L/360	L/600	L/240	L/360	L/600
600S200-33	12	21' 7" e	20' 6" e	17' 3"	18' 8" e	18' 7" e	15' 8" e	16' 8" e	16' 8" e	14' 7" e	15' 3" e	15' 3" e	13' 8" e	14' 1" e	14' 1" e	13' 0" e	13' 2" e	13' 2" e	12' 5" e
	16	18' 8" e	18' 7" e	15' 8" e	16' 2" e	16' 2" e	14' 3" e	14' 6" e	14' 6" e	13' 3" e	13' 2" e	13' 2" e	12' 5" e	12' 3" e	12' 3" e	11' 10" e	11' 5" e	11' 5" e	11' 4" e
	24	15' 3" e	15' 3" e	13' 8" e	13' 2" e	13' 2" e	12' 5" e	11' 10" e	11' 10" e	11' 7" e	10' 9" e	10' 9" e	10' 9" e	10' 0" e	10' 0" e	10' 0" e	9' 4" e	9' 4" e	9' 4" e
600S200-43	12	25' 7"	22' 4"	18' 10"	22' 4"	20' 4"	17' 2"	19' 11"	18' 10"	15' 11"	18' 3" e	17' 9" e	15' 0"	16' 10" e	16' 10" e	14' 3"	15' 9" e	15' 9" e	13' 7" e
	16	22' 4"	20' 4"	17' 2"	19' 4"	18' 5"	15' 7"	17' 3" e	17' 2" e	14' 5"	15' 9" e	15' 9" e	13' 7" e	14' 7" e	14' 7" e	12' 11" e	13' 8" e	13' 8" e	12' 4" e
	24	18' 3" e	17' 9" e	15' 0"	15' 9" e	15' 9" e	13' 7" e	14' 1" e	14' 1" e	12' 7" e	12' 11" e	12' 11" e	11' 11" e	11' 11" e	11' 11" e	11' 3" e	11' 2" e	11' 2" e	10' 9" e
600S200-54	12	27' 6"	24' 0"	20' 3"	24' 11"	21' 10"	18' 5"	23' 2"	20' 3"	17' 1"	21' 10"	19' 1"	16' 1"	20' 9"	18' 1"	15' 3"	19' 10"	17' 4"	14' 7"
	16	24' 11"	21' 10"	18' 5"	22' 8"	19' 10"	16' 8"	21' 1"	18' 5"	15' 6"	19' 10"	17' 4"	14' 7"	18' 10"	16' 5"	13' 10"	18' 0"	15' 9"	13' 3"
	24	21' 10"	19' 1"	16' 1"	19' 10"	17' 4"	14' 7"	18' 5"	16' 1"	13' 7"	17' 2"	15' 1"	12' 9"	15' 10"	14' 4"	12' 1"	14' 10"	13' 9"	11' 7"
600S200-68	12	29' 6"	25' 9"	21' 9"	26' 9"	23' 5"	19' 9"	24' 10"	21' 9"	18' 4"	23' 5"	20' 5"	17' 3"	22' 3"	19' 5"	16' 4"	21' 3"	18' 7"	15' 8"
	16	26' 9"	23' 5"	19' 9"	24' 4"	21' 3"	17' 11"	22' 7"	19' 9"	16' 8"	21' 3"	18' 7"	15' 8"	20' 2"	17' 8"	14' 11"	19' 4"	16' 10"	14' 3"
	24	23' 5"	20' 5"	17' 3"	21' 3"	18' 7"	15' 8"	19' 9"	17' 3"	14' 6"	18' 7"	16' 3"	13' 8"	17' 8"	15' 5"	13' 0"	16' 10"	14' 9"	12' 5"
600S200-97	12	32' 9"	28' 7"	24' 1"	29' 9"	26' 0"	21' 11"	27' 7"	24' 1"	20' 4"	26' 0"	22' 8"	19' 2"	24' 8"	21' 7"	18' 2"	23' 7"	20' 7"	17' 5"
	16	29' 9"	26' 0"	21' 11"	27' 0"	23' 7"	19' 11"	25' 1"	21' 11"	18' 6"	23' 7"	20' 7"	17' 5"	22' 5"	19' 7"	16' 6"	21' 5"	18' 9"	15' 10"
	24	26' 0"	22' 8"	19' 2"	23' 7"	20' 7"	17' 5"	21' 11"	19' 2"	16' 2"	20' 7"	18' 0"	15' 2"	19' 7"	17' 1"	14' 5"	18' 9"	16' 4"	13' 10"
600S250-43	12	26' 5"	23' 5"	19' 9"	22' 11"	21' 3"	17' 11"	20' 6"	19' 9"	16' 8"	18' 8" e	18' 7" e	15' 8"	17' 4" e	17' 4" e	14' 11" e	16' 2" e	16' 2" e	14' 3" e
	16	22' 11"	21' 3"	17' 11"	19' 10" e	19' 4"	16' 4"	17' 9" e	17' 9" e	15' 2"	16' 2" e	16' 2" e	14' 3" e	15' 0" e	15' 0" e	13' 6" e	14' 0" e	14' 0" e	12' 11" e
	24	18' 8" e	18' 7" e	15' 8"	16' 2" e	16' 2" e	14' 3" e	14' 6" e	14' 6" e	13' 3" e	13' 3" e	13' 3" e	12' 5" e	12' 3" e	12' 3" e	11' 10" e	11' 5" e	11' 5" e	11' 4" e
600S250-54	12	28' 8"	25' 0"	21' 1"	26' 0"	22' 9"	19' 2"	24' 2"	21' 1"	17' 10"	22' 9"	19' 10"	16' 9"	21' 7"	18' 10"	15' 11"	20' 8"	18' 1"	15' 3"
	16	26' 0"	22' 9"	19' 2"	23' 8"	20' 8"	17' 5"	21' 11"	19' 2"	16' 2"	20' 8"	18' 1"	15' 3"	19' 7"	17' 2"	14' 6"	18' 8"	16' 5"	13' 10"
	24	22' 9"	19' 10"	16' 9"	20' 8"	18' 1"	15' 3"	19' 2"	16' 9"	14' 2"	17' 7"	15' 9"	13' 4"	16' 3"	15' 0"	12' 8"	15' 2" e	14' 4"	12' 1"
600S250-68	12	30' 11"	27' 0"	22' 9"	28' 1"	24' 6"	20' 8"	26' 1"	22' 9"	19' 2"	24' 6"	21' 5"	18' 1"	23' 4"	20' 4"	17' 2"	22' 3"	19' 6"	16' 5"
	16	28' 1"	24' 6"	20' 8"	25' 6"	22' 3"	18' 10"	23' 8"	20' 8"	17' 5"	22' 3"	19' 6"	16' 5"	21' 2"	18' 6"	15' 7"	20' 3"	17' 8"	14' 11"
	24	24' 6"	21' 5"	18' 1"	22' 3"	19' 6"	16' 5"	20' 8"	18' 1"	15' 3"	19' 6"	17' 0"	14' 4"	18' 6"	16' 2"	13' 7"	17' 8"	15' 5"	13' 0"
600S250-97	12	34' 4"	30' 0"	25' 4"	31' 3"	27' 3"	23' 0"	29' 0"	25' 4"	21' 4"	27' 3"	23' 10"	20' 1"	25' 11"	22' 8"	19' 1"	24' 9"	21' 8"	18' 3"
	16	31' 3"	27' 3"	23' 0"	28' 4"	24' 9"	20' 11"	26' 4"	23' 0"	19' 5"	24' 9"	21' 8"	18' 3"	23' 6"	20' 7"	17' 4"	22' 6"	19' 8"	16' 7"
	24	27' 3"	23' 10"	20' 1"	24' 9"	21' 8"	18' 3"	23' 0"	20' 1"	16' 11"	21' 8"	18' 11"	15' 11"	20' 7"	18' 0"	15' 2"	19' 8"	17' 2"	14' 6"
600S300-54	12	29' 3"	25' 7"	21' 7"	26' 7"	23' 3"	19' 7"	24' 8"	21' 7"	18' 2"	23' 3"	20' 3"	17' 1"	22' 1"	19' 3"	16' 3"	21' 1"	18' 5"	15' 7"
	16	26' 7"	23' 3"	19' 7"	24' 2"	21' 1"	17' 10"	22' 5"	19' 7"	16' 6"	21' 1"	18' 5"	15' 7"	20' 1"	17' 6"	14' 9"	18' 11"	16' 9"	14' 2"
	24	23' 3"	20' 3"	17' 1"	21' 1"	18' 5"	15' 7"	19' 7"	17' 1"	14' 5"	17' 10"	16' 1"	13' 7"	16' 6"	15' 4"	12' 11"	15' 6" e	14' 8"	12' 4"
600S300-68	12	31' 11"	27' 11"	23' 6"	29' 0"	25' 4"	21' 5"	26' 11"	23' 6"	19' 10"	25' 4"	22' 2"	18' 8"	24' 1"	21' 0"	17' 9"	23' 0"	20' 2"	17' 0"
	16	29' 0"	25' 4"	21' 5"	26' 4"	23' 0"	19' 5"	24' 6"	21' 5"	18' 0"	23' 0"	20' 2"	17' 0"	21' 11"	19' 1"	16' 1"	20' 11"	18' 3"	15' 5"
	24	25' 4"	22' 2"	18' 8"	23' 0"	20' 2"	17' 0"	21' 5"	18' 8"	15' 9"	20' 2"	17' 7"	14' 10"	19' 1"	16' 8"	14' 1"	18' 1"	16' 0"	13' 6"
600S300-97	12	35' 8"	31' 2"	26' 4"	32' 5"	28' 4"	23' 11"	30' 1"	26' 4"	22' 2"	28' 4"	24' 9"	20' 10"	26' 11"	23' 6"	19' 10"	25' 9"	22' 6"	19' 0"
	16	32' 5"	28' 4"	23' 11"	29' 6"	25' 9"	21' 8"	27' 4"	23' 11"	20' 2"	25' 9"	22' 6"	19' 0"	24' 5"	21' 4"	18' 0"	23' 5"	20' 5"	17' 3"
	24	28' 4"	24' 9"	20' 10"	25' 9"	22' 6"	19' 0"	23' 11"	20' 10"	17' 7"	22' 6"	19' 8"	16' 7"	21' 4"	18' 8"	15' 9"	20' 5"	17' 10"	15' 1"

See page 27 for clarification of code developed wind pressures prior to using this table.

Notes:

- 1 Studs are checked for simple-span deflection and stress. Stress calculations are made for mid-span fully braced moment, end shear through the unperforated section and shear moment interaction through the perforated section 10" away from the end bearing.
- 2 A 1/3 stress increase is not used.
- 3 Limiting heights are based on continuous lateral support of each flange over the full height of the stud.
- 4 Listed limiting heights are based on steel properties only.
- 5 For bending, studs are assumed to be adequately braced to develop full allowable moment capacity. Stud distortional buckling based on an assumed $K\phi = 0$.
- 6 Web crippling check based on 1-inch end bearing. Web stiffeners are required when listed limiting heights are followed by "e".
- 7 Members marked with an ¹ have $h/t > 200$, and thus require end stiffeners.
- 8 Capacities are calculated according to the AISI S100-16 (2020) w/S2-20. A 1-1/2" by 4" knockout spaced no closer than 24" o.c. is assumed. (3/4" for 2-1/2" studs)
- 9 All values are based on $F_y=33\text{ksi}$ for 33mil and 43mil Studs, and $F_y=50\text{ksi}$ for 54mil, 68mil and 97mil Studs.
- 10 For deflection calculations, 15psf and higher wind pressures have been multiplied by 0.7, in accordance with footnote "f" of IBC table 1604.3. The 5 psf pressure has not been reduced for deflection checks.
- 11 Lateral loads have not been modified for strength checks. Full loads are applied.
- 12 End reactions must be checked for web crippling separately.

Complies with AISI S100-16 (2020) w/S2-20 • IBC 2024

CURTAIN WALL HEIGHTS

Member	Spacing (in) o.c.	15psf			20psf			25psf			30psf			35psf			40psf		
		L/240	L/360	L/600	L/240	L/360	L/600	L/240	L/360	L/600	L/240	L/360	L/600	L/240	L/360	L/600	L/240	L/360	L/600
800S137-33 ¹	12	21' 5" e	21' 5" e	19' 7" e	18' 6" e	18' 6" e	17' 9" e	16' 7" e	16' 7" e	16' 6" e	15' 1" e	15' 1" e	15' 1" e	14' 0" e	14' 0" e	14' 0" e	13' 1" e	13' 1" e	13' 1" e
	16	18' 6" e	18' 6" e	17' 9" e	16' 0" e	16' 0" e	16' 0" e	14' 4" e	14' 4" e	14' 4" e	13' 1" e	13' 1" e	13' 1" e	12' 2" e	12' 2" e	12' 2" e	11' 4" e	11' 4" e	11' 4" e
	24	15' 1" e	15' 1" e	15' 1" e	13' 1" e	13' 1" e	13' 1" e	11' 9" e	11' 9" e	11' 9" e	10' 8" e	10' 8" e	10' 8" e	9' 11" e	9' 11" e	9' 11" e	9' 3" e	9' 3" e	9' 3" e
800S137-43	12	25' 11" e	25' 6" e	21' 6" e	22' 5" e	22' 5" e	19' 7" e	20' 1" e	20' 1" e	18' 2" e	18' 4" e	18' 4" e	17' 1" e	16' 11" e	16' 11" e	16' 3" e	15' 10" e	15' 10" e	15' 6" e
	16	22' 5" e	22' 5" e	19' 7" e	19' 5" e	19' 5" e	17' 9" e	17' 5" e	17' 5" e	16' 6" e	15' 10" e	15' 10" e	15' 6" e	14' 8" e	14' 8" e	14' 8" e	13' 9" e	13' 9" e	13' 9" e
	24	18' 4" e	18' 4" e	17' 1" e	15' 10" e	15' 10" e	15' 6" e	14' 2" e	14' 2" e	14' 2" e	12' 11" e	12' 11" e	12' 11" e	12' 0" e	12' 0" e	12' 0" e	11' 3" e	11' 3" e	11' 3" e
800S137-54	12	31' 5" e	27' 6" e	23' 2" e	28' 7" e	24' 11" e	21' 1" e	26' 6" e	23' 2" e	19' 6" e	24' 6" e	21' 10" e	18' 5" e	22' 8" e	20' 8" e	17' 6" e	21' 3" e	19' 10" e	16' 8" e
	16	28' 7" e	24' 11" e	21' 1" e	25' 11" e	22' 8" e	19' 1" e	23' 3" e	21' 1" e	17' 9" e	21' 3" e	19' 10" e	16' 8" e	19' 8" e	18' 10" e	15' 10" e	18' 5" e	18' 0" e	15' 2" e
	24	24' 6" e	21' 10" e	18' 5" e	21' 3" e	19' 10" e	16' 8" e	19' 0" e	18' 5" e	15' 6" e	17' 4" e	17' 4" e	14' 7" e	16' 0" e	16' 0" e	13' 10" e	15' 0" e	15' 0" e	13' 3" e
800S137-68	12	34' 0" e	29' 8" e	25' 0" e	30' 11" e	22' 9" e	22' 9" e	28' 8" e	25' 0" e	21' 1" e	27' 0" e	23' 7" e	19' 10" e	25' 7" e	22' 5" e	18' 11" e	24' 6" e	21' 5" e	18' 1" e
	16	30' 11" e	27' 0" e	22' 9" e	28' 1" e	24' 6" e	20' 8" e	26' 0" e	22' 9" e	19' 2" e	24' 6" e	21' 5" e	18' 1" e	23' 1" e	20' 4" e	17' 2" e	21' 7" e	19' 5" e	16' 5" e
	24	27' 0" e	23' 7" e	19' 10" e	24' 6" e	21' 5" e	18' 1" e	22' 4" e	19' 10" e	16' 9" e	20' 5" e	18' 8" e	15' 9" e	18' 10" e	17' 9" e	15' 0" e	17' 8" e	17' 0" e	14' 4" e
800S137-97	12	37' 9" e	32' 11" e	27' 10" e	34' 3" e	29' 11" e	25' 3" e	31' 10" e	27' 10" e	23' 5" e	29' 11" e	26' 2" e	22' 1" e	28' 5" e	24' 10" e	20' 11" e	27' 2" e	23' 9" e	20' 1" e
	16	34' 3" e	29' 11" e	25' 3" e	31' 2" e	27' 2" e	22' 11" e	28' 11" e	25' 3" e	21' 4" e	27' 2" e	23' 9" e	20' 1" e	25' 10" e	22' 7" e	19' 0" e	24' 9" e	21' 7" e	18' 3" e
	24	29' 11" e	26' 2" e	22' 1" e	27' 2" e	23' 9" e	20' 1" e	25' 3" e	22' 1" e	18' 7" e	23' 9" e	20' 9" e	17' 6" e	22' 7" e	19' 9" e	16' 8" e	21' 7" e	18' 10" e	15' 11" e
800S162-33 ¹	12	23' 4" e	23' 4" e	20' 4" e	20' 2" e	20' 2" e	18' 6" e	18' 1" e	18' 1" e	17' 2" e	16' 6" e	16' 6" e	16' 2" e	15' 3" e	15' 3" e	15' 3" e	14' 3" e	14' 3" e	14' 3" e
	16	20' 2" e	20' 2" e	18' 6" e	17' 6" e	17' 6" e	16' 10" e	15' 8" e	15' 8" e	15' 7" e	14' 3" e	14' 3" e	14' 3" e	13' 3" e	13' 3" e	13' 3" e	12' 4" e	12' 4" e	12' 4" e
	24	16' 6" e	16' 6" e	16' 2" e	14' 3" e	14' 3" e	14' 3" e	12' 9" e	12' 9" e	12' 9" e	11' 8" e	11' 8" e	11' 8" e	10' 9" e	10' 9" e	10' 9" e	10' 1" e	10' 1" e	10' 1" e
800S162-43	12	28' 1" e	26' 7" e	22' 5" e	24' 4" e	24' 2" e	20' 4" e	21' 9" e	21' 9" e	18' 11" e	19' 10" e	19' 10" e	17' 9" e	18' 4" e	18' 4" e	16' 11" e	17' 2" e	17' 2" e	16' 2" e
	16	24' 4" e	24' 2" e	20' 4" e	21' 1" e	21' 1" e	18' 6" e	18' 10" e	18' 10" e	17' 2" e	17' 2" e	16' 2" e	15' 11" e	15' 11" e	15' 4" e	14' 11" e	14' 11" e	14' 8" e	
	24	19' 10" e	19' 10" e	17' 9" e	17' 2" e	17' 2" e	16' 2" e	15' 4" e	15' 4" e	15' 0" e	14' 0" e	14' 0" e	14' 0" e	13' 0" e	13' 0" e	13' 0" e	12' 2" e	12' 2" e	12' 2" e
800S162-54	12	32' 8" e	28' 7" e	24' 1" e	29' 9" e	25' 11" e	21' 11" e	27' 7" e	24' 1" e	20' 4" e	25' 11" e	22' 8" e	19' 1" e	24' 6" e	21' 6" e	18' 2" e	22' 11" e	20' 7" e	17' 4" e
	16	29' 9" e	25' 11" e	21' 11" e	27' 0" e	23' 7" e	19' 11" e	25' 1" e	21' 11" e	18' 6" e	22' 11" e	20' 7" e	17' 4" e	21' 3" e	19' 7" e	16' 6" e	19' 10" e	18' 9" e	15' 9" e
	24	25' 11" e	22' 8" e	19' 1" e	22' 11" e	20' 7" e	17' 4" e	20' 6" e	19' 1" e	16' 2" e	18' 9" e	18' 0" e	15' 2" e	17' 4" e	17' 1" e	14' 5" e	16' 2" e	16' 2" e	13' 9" e
800S162-68	12	35' 4" e	30' 10" e	26' 0" e	32' 1" e	28' 1" e	23' 8" e	29' 10" e	26' 0" e	22' 0" e	28' 1" e	24' 6" e	20' 8" e	26' 8" e	23' 3" e	19' 8" e	25' 6" e	22' 3" e	18' 9" e
	16	32' 1" e	28' 1" e	23' 8" e	29' 2" e	25' 6" e	21' 6" e	27' 1" e	23' 8" e	19' 11" e	25' 6" e	22' 3" e	18' 9" e	24' 3" e	21' 2" e	17' 10" e	23' 2" e	20' 3" e	17' 1" e
	24	28' 1" e	24' 6" e	20' 8" e	25' 6" e	22' 3" e	18' 9" e	23' 8" e	20' 8" e	17' 5" e	21' 11" e	19' 5" e	16' 5" e	20' 4" e	18' 6" e	15' 7" e	19' 0" e	17' 8" e	14' 11" e
800S162-97	12	39' 3" e	34' 4" e	28' 11" e	35' 8" e	31' 2" e	26' 4" e	33' 2" e	28' 11" e	24' 5" e	31' 2" e	27' 3" e	23' 0" e	29' 7" e	25' 11" e	21' 10" e	28' 4" e	24' 9" e	20' 11" e
	16	35' 8" e	31' 2" e	26' 4" e	32' 5" e	28' 4" e	23' 11" e	30' 1" e	26' 4" e	22' 2" e	28' 4" e	24' 9" e	20' 11" e	26' 11" e	23' 6" e	19' 10" e	25' 9" e	22' 6" e	19' 0" e
	24	31' 2" e	27' 3" e	23' 0" e	28' 4" e	24' 9" e	20' 11" e	26' 4" e	23' 0" e	19' 5" e	24' 9" e	21' 7" e	18' 3" e	23' 6" e	20' 6" e	17' 4" e	22' 6" e	19' 8" e	16' 7" e

See page 27 for clarification of code developed wind pressures prior to using this table.

Notes:

- 1 Studs are checked for simple-span deflection and stress. Stress calculations are made for mid-span fully braced moment, end shear through the unperforated section and shear moment interaction through the perforated section 10' away from the end bearing.
- 2 A 1/3 stress increase is not used.
- 3 Limiting heights are based on continuous lateral support of each flange over the full height of the stud.
- 4 Listed limiting heights are based on steel properties only.
- 5 For bending, studs are assumed to be adequately braced to develop full allowable moment capacity. Stud distortional buckling based on an assumed $K\phi = 0$.
- 6 Web crippling check based on 1-inch end bearing. Web stiffeners are required when listed limiting heights are followed by "e".
- 7 Members marked with an ¹ have $h/t > 200$, and thus require end stiffeners.
- 8 Capacities are calculated according to the AISI S100-16 (2020) w/S2-20. A 1-1/2" by 4" knockout spaced no closer than 24" o.c. is assumed. (3/4" for 2-1/2" studs)
- 9 All values are based on $F_y=33$ ksi for 33mil and 43mil Studs, and $F_y=50$ ksi for 54mil, 68mil and 97mil Studs.
- 10 For deflection calculations, 15psf and higher wind pressures have been multiplied by 0.7, in accordance with footnote "f" of IBC table 1604.3. The 5 psf pressure has not been reduced for deflection checks.
- 11 Lateral loads have not been modified for strength checks. Full loads are applied.
- 12 End reactions must be checked for web crippling separately.

Complies with AISI S100-16 (2020) w/S2-20 • IBC 2024

CURTAIN WALL HEIGHTS

Member	Spacing (in) o.c.	15psf			20psf			25psf			30psf			35psf			40psf		
		L/240	L/360	L/600	L/240	L/360	L/600	L/240	L/360	L/600	L/240	L/360	L/600	L/240	L/360	L/600	L/240	L/360	L/600
800S200-33 ¹	12	25' 1" e	25' 1" e	21' 8" e	21' 9" e	21' 9" e	19' 9" e	19' 5" e	19' 5" e	18' 4" e	17' 9" e	17' 9" e	17' 3" e	16' 5" e	16' 5" e	16' 4" e	15' 4" e	15' 4" e	15' 4" e
	16	21' 9" e	21' 9" e	19' 9" e	18' 10" e	18' 10" e	17' 11" e	16' 10" e	16' 10" e	16' 8" e	15' 4" e	15' 4" e	15' 4" e	14' 3" e	14' 3" e	14' 3" e	13' 4" e	13' 4" e	13' 4" e
	24	17' 9" e	17' 9" e	17' 3" e	15' 4" e	15' 4" e	15' 4" e	13' 9" e	13' 9" e	13' 9" e	12' 6" e	12' 6" e	12' 6" e	11' 7" e	11' 7" e	11' 7" e	10' 10" e	10' 10" e	10' 10" e
800S200-43	12	30' 1" e	28' 1" e	23' 8" e	26' 1" e	25' 6" e	21' 6" e	23' 4" e	23' 4" e	19' 11" e	21' 4" e	21' 4" e	18' 9" e	19' 9" e	19' 9" e	17' 10" e	18' 5" e	18' 5" e	17' 1" e
	16	26' 1" e	25' 6" e	21' 6" e	22' 7" e	22' 7" e	19' 6" e	20' 2" e	20' 2" e	18' 2" e	18' 5" e	18' 5" e	17' 1" e	17' 1" e	17' 1" e	16' 2" e	16' 0" e	16' 0" e	15' 6" e
	24	21' 4" e	21' 4" e	18' 9" e	18' 5" e	18' 5" e	17' 1" e	16' 6" e	16' 6" e	15' 10" e	15' 1" e	15' 1" e	14' 11" e	13' 11" e	13' 11" e	13' 11" e	13' 1" e	13' 1" e	13' 1" e
800S200-54	12	34' 6" e	30' 2" e	25' 5" e	31' 4" e	27' 5" e	23' 1" e	29' 1" e	25' 5" e	21' 5" e	27' 5" e	23' 11" e	20' 2" e	26' 0" e	22' 9" e	19' 2" e	24' 7" e	21' 9" e	18' 4" e
	16	31' 4" e	27' 5" e	23' 1" e	28' 6" e	24' 10" e	21' 0" e	26' 5" e	23' 1" e	19' 6" e	24' 7" e	21' 9" e	18' 4" e	22' 9" e	20' 8" e	17' 5" e	21' 3" e	19' 9" e	16' 8" e
	24	27' 5" e	23' 11" e	20' 2" e	24' 7" e	21' 9" e	18' 4" e	22' 0" e	20' 2" e	17' 0" e	20' 1" e	19' 0" e	16' 0" e	18' 7" e	18' 0" e	15' 2" e	17' 4" e	17' 3" e	14' 7" e
800S200-68	12	37' 1" e	32' 4" e	27' 4" e	33' 8" e	29' 5" e	24' 10" e	31' 3" e	27' 4" e	23' 0" e	29' 5" e	25' 8" e	21' 8" e	27' 11" e	24' 5" e	20' 7" e	26' 9" e	23' 4" e	19' 8" e
	16	33' 8" e	29' 5" e	24' 10" e	30' 7" e	26' 9" e	22' 6" e	28' 5" e	24' 10" e	20' 11" e	26' 9" e	23' 4" e	19' 8" e	25' 4" e	22' 2" e	18' 8" e	24' 3" e	21' 2" e	17' 11" e
	24	29' 5" e	25' 8" e	21' 8" e	26' 9" e	23' 4" e	19' 8" e	24' 10" e	21' 8" e	18' 3" e	23' 4" e	20' 5" e	17' 2" e	21' 8" e	19' 4" e	16' 4" e	20' 3" e	18' 6" e	15' 7" e
800S200-97	12	41' 2" e	36' 0" e	30' 4" e	37' 5" e	32' 8" e	27' 7" e	34' 9" e	30' 4" e	25' 7" e	32' 8" e	28' 7" e	24' 1" e	31' 1" e	27' 2" e	22' 11" e	29' 9" e	25' 11" e	21' 11" e
	16	37' 5" e	32' 8" e	27' 7" e	34' 0" e	29' 9" e	25' 1" e	31' 7" e	27' 7" e	23' 3" e	29' 9" e	25' 11" e	21' 11" e	28' 3" e	24' 8" e	20' 10" e	27' 0" e	23' 7" e	19' 11" e
	24	32' 8" e	28' 7" e	24' 1" e	29' 9" e	25' 11" e	21' 11" e	27' 7" e	24' 1" e	20' 4" e	25' 11" e	22' 8" e	19' 1" e	24' 8" e	21' 6" e	18' 2" e	23' 7" e	20' 7" e	17' 5" e
800S250-43	12	30' 11" e	29' 3" e	24' 8" e	26' 9" e	26' 7" e	22' 5" e	23' 11" e	23' 11" e	20' 10" e	21' 10" e	21' 10" e	19' 7" e	20' 3" e	20' 3" e	18' 7" e	18' 11" e	18' 11" e	17' 10" e
	16	26' 9" e	26' 7" e	22' 5" e	23' 2" e	23' 2" e	20' 4" e	20' 9" e	20' 9" e	18' 11" e	18' 11" e	18' 11" e	17' 10" e	17' 6" e	17' 6" e	16' 11" e	16' 5" e	16' 5" e	16' 2" e
	24	21' 10" e	21' 10" e	19' 7" e	18' 11" e	18' 11" e	17' 10" e	16' 11" e	16' 11" e	16' 6" e	15' 5" e	15' 5" e	15' 5" e	14' 4" e	14' 4" e	14' 4" e	13' 5" e	13' 5" e	13' 5" e
800S250-54	12	35' 10" e	31' 4" e	26' 5" e	32' 7" e	28' 5" e	24' 0" e	30' 3" e	26' 5" e	22' 3" e	28' 5" e	24' 10" e	21' 0" e	26' 11" e	23' 7" e	19' 11" e	25' 2" e	22' 7" e	19' 1" e
	16	32' 7" e	28' 5" e	24' 0" e	29' 7" e	25' 10" e	21' 10" e	27' 6" e	24' 0" e	20' 3" e	25' 2" e	22' 7" e	19' 1" e	23' 3" e	21' 5" e	18' 1" e	21' 9" e	20' 6" e	17' 4" e
	24	28' 5" e	24' 10" e	21' 0" e	25' 2" e	22' 7" e	19' 1" e	22' 6" e	21' 0" e	17' 8" e	20' 6" e	19' 9" e	16' 8" e	19' 0" e	18' 9" e	15' 10" e	17' 9" e	17' 9" e	15' 1" e
800S250-68	12	38' 8" e	33' 9" e	28' 6" e	35' 1" e	30' 8" e	25' 10" e	32' 7" e	28' 6" e	24' 0" e	30' 8" e	26' 10" e	22' 7" e	29' 2" e	25' 5" e	21' 6" e	27' 10" e	24' 4" e	20' 6" e
	16	35' 1" e	30' 8" e	25' 10" e	31' 11" e	27' 10" e	23' 6" e	29' 7" e	25' 10" e	21' 10" e	27' 10" e	24' 4" e	20' 6" e	22' 7" e	19' 1" e	24' 0" e	21' 3" e	17' 11" e	22' 3" e
	24	30' 8" e	26' 10" e	22' 7" e	27' 10" e	24' 4" e	20' 6" e	25' 10" e	22' 7" e	19' 1" e	24' 0" e	21' 3" e	17' 11" e	22' 3" e	20' 2" e	17' 0" e	20' 10" e	19' 4" e	16' 4" e
800S250-97	12	43' 1" e	37' 7" e	31' 9" e	39' 2" e	34' 2" e	28' 10" e	36' 4" e	31' 9" e	26' 9" e	34' 2" e	29' 10" e	25' 2" e	32' 6" e	28' 4" e	23' 11" e	31' 1" e	27' 2" e	22' 11" e
	16	39' 2" e	34' 2" e	28' 10" e	35' 7" e	31' 1" e	26' 2" e	33' 0" e	28' 10" e	24' 4" e	31' 1" e	27' 2" e	22' 11" e	29' 6" e	25' 9" e	21' 9" e	28' 3" e	24' 8" e	20' 9" e
	24	34' 2" e	29' 10" e	25' 2" e	31' 1" e	27' 2" e	22' 11" e	28' 10" e	25' 2" e	21' 3" e	27' 2" e	23' 8" e	20' 0" e	25' 9" e	22' 6" e	19' 0" e	24' 8" e	21' 6" e	18' 2" e
800S300-54	12	36' 7" e	32' 0" e	27' 0" e	33' 3" e	29' 1" e	24' 6" e	30' 11" e	27' 0" e	22' 9" e	29' 1" e	25' 5" e	21' 5" e	27' 3" e	24' 1" e	20' 4" e	25' 6" e	23' 1" e	19' 5" e
	16	33' 3" e	29' 1" e	24' 6" e	30' 3" e	26' 5" e	22' 3" e	27' 11" e	24' 6" e	20' 8" e	25' 6" e	23' 1" e	19' 5" e	23' 7" e	21' 11" e	18' 6" e	22' 1" e	20' 11" e	17' 8" e
	24	29' 1" e	25' 5" e	21' 5" e	25' 6" e	23' 1" e	19' 5" e	22' 10" e	21' 5" e	18' 1" e	20' 10" e	20' 2" e	17' 0" e	19' 3" e	19' 2" e	16' 2" e	18' 0" e	18' 0" e	15' 5" e
800S300-68	12	39' 9" e	34' 9" e	29' 4" e	36' 2" e	31' 7" e	26' 8" e	33' 7" e	29' 4" e	24' 9" e	31' 7" e	27' 7" e	23' 3" e	30' 0" e	26' 2" e	22' 1" e	28' 8" e	25' 1" e	21' 2" e
	16	36' 2" e	31' 7" e	26' 8" e	32' 10" e	28' 8" e	24' 2" e	30' 6" e	26' 8" e	22' 6" e	28' 8" e	25' 1" e	21' 2" e	27' 3" e	23' 10" e	20' 1" e	25' 11" e	22' 9" e	19' 2" e
	24	31' 7" e	27' 7" e	23' 3" e	28' 8" e	25' 1" e	21' 2" e	26' 8" e	23' 3" e	19' 7" e	24' 5" e	21' 11" e	18' 6" e	22' 7" e	20' 10" e	17' 6" e	21' 2" e	19' 11" e	16' 9" e
800S300-97	12	44' 7" e	38' 11" e	32' 10" e	40' 6" e	35' 4" e	29' 10" e	37' 7" e	32' 10" e	27' 8" e	35' 4" e	30' 11" e	26' 1" e	33' 7" e	29' 4" e	24' 9" e	32' 2" e	28' 1" e	23' 8" e
	16	40' 6" e	35' 4" e	29' 10" e	36' 9" e	32' 2" e	27' 1" e	34' 2" e	29' 10" e	25' 2" e	32' 2" e	28' 1" e	23' 8" e	30' 6" e	26' 8" e	22' 6" e	29' 2" e	25' 6" e	21' 6" e
	24	35' 4" e	30' 11" e	26' 1" e	32' 2" e	28' 1" e	23' 8" e	29' 10" e	26' 1" e	22' 0" e	28' 1" e	24' 6" e	20' 8" e	26' 8" e	23' 4" e	19' 8" e	25' 6" e	22' 3" e	18' 10" e

See page 27 for clarification of code developed wind pressures prior to using this table.

- Notes:**
- 1 Studs are checked for simple-span deflection and stress. Stress calculations are made for mid-span fully braced moment, end shear through the unperforated section and shear moment interaction through the perforated section 10" away from the end bearing.
 - 2 A 1/3 stress increase is not used.
 - 3 Limiting heights are based on continuous lateral support of each flange over the full height of the stud.
 - 4 Listed limiting heights are based on steel properties only.
 - 5 For bending, studs are assumed to be adequately braced to develop full allowable moment capacity. Stud distortional buckling based on an assumed $K\phi = 0$.
 - 6 Web crippling check based on 1-inch end bearing. Web stiffeners are required when listed limiting heights are followed by "e".
 - 7 Members marked with an ¹ have h/t > 200, and thus require end stiffeners.
 - 8 Capacities are calculated according to the AISI S100-16 (2020) w/S2-20. A 1-1/2" by 4" knockout spaced no closer than 24" o.c. is assumed. (3/4" for 2-1/2" studs)
 - 9 All values are based on Fy=33ksi for 33mil and 43mil Studs, and Fy=50ksi for 54mil, 68mil and 97mil Studs.
 - 10 For deflection calculations, 15psf and higher wind pressures have been multiplied by 0.7, in accordance with footnote "f" of IBC table 1604.3. The 5 psf pressure has not been reduced for deflection checks.
 - 11 Lateral loads have not been modified for strength checks. Full loads are applied.
 - 12 End reactions must be checked for web crippling separately.

Complies with AISI S100-16 (2020) w/S2-20 • IBC 2024

CURTAIN WALL HEIGHTS

Member	Spacing (in) o.c.	15psf			20psf			25psf			30psf			35psf			40psf		
		L/240	L/360	L/600	L/240	L/360	L/600	L/240	L/360	L/600	L/240	L/360	L/600	L/240	L/360	L/600	L/240	L/360	L/600
1000S162-43 ¹	12	31' 2" e	31' 2" e	26' 7"	27' 0" e	27' 0" e	24' 2" e	24' 1" e	24' 1" e	22' 5" e	22' 0" e	22' 0" e	21' 1" e	20' 5" e	20' 5" e	20' 1" e	19' 1" e	19' 1" e	19' 1" e
	16	27' 0" e	27' 0" e	24' 2" e	23' 4" e	23' 4" e	21' 11" e	20' 11" e	20' 11" e	20' 4" e	19' 1" e	19' 1" e	19' 1" e	17' 8" e	17' 8" e	17' 8" e	16' 6" e	16' 6" e	16' 6" e
	24	22' 0" e	22' 0" e	21' 1" e	19' 1" e	19' 1" e	19' 1" e	17' 1" e	17' 1" e	17' 1" e	15' 7" e	15' 7" e	15' 7" e	14' 5" e	14' 5" e	14' 5" e	13' 6" e	13' 6" e	13' 6" e
1000S162-54	12	38' 10"	33' 11"	28' 7"	35' 4"	30' 10"	26' 0"	32' 3"	28' 7"	24' 2"	29' 5"	26' 11"	22' 9"	27' 3"	25' 7"	21' 7"	25' 6"	24' 6"	20' 8"
	16	35' 4"	30' 10"	26' 0"	31' 2"	28' 0"	23' 8"	27' 11"	26' 0"	21' 11"	25' 6"	24' 6"	20' 8"	23' 7" e	23' 3" e	19' 7"	22' 1" e	22' 1" e	18' 9"
	24	29' 5"	26' 11"	22' 9"	25' 6"	24' 6"	20' 8"	22' 9" e	22' 9" e	19' 2"	20' 10" e	20' 10" e	18' 0" e	19' 3" e	19' 3" e	17' 2" e	18' 0" e	18' 0" e	16' 5" e
1000S162-68	12	42' 2"	36' 10"	31' 1"	38' 3"	33' 5"	28' 2"	35' 6"	31' 1"	26' 2"	33' 5"	29' 3"	24' 8"	31' 9"	27' 9"	23' 5"	30' 1"	26' 6"	22' 5"
	16	38' 3"	33' 5"	28' 2"	34' 9"	30' 5"	25' 8"	32' 3"	28' 2"	23' 9"	30' 1"	26' 6"	22' 5"	27' 10"	25' 3"	21' 3"	26' 0"	24' 1"	20' 4"
	24	33' 5"	29' 3"	24' 8"	30' 1"	26' 6"	22' 5"	26' 11"	24' 8"	20' 9"	24' 6"	23' 2"	19' 7"	22' 9"	22' 0"	18' 7"	21' 3" e	21' 1" e	17' 9"
1000S162-97	12	47' 4"	41' 4"	34' 10"	43' 0"	37' 7"	31' 8"	39' 11"	34' 10"	29' 5"	37' 7"	32' 10"	27' 8"	35' 8"	31' 2"	26' 3"	34' 1"	29' 10"	25' 2"
	16	43' 0"	37' 7"	31' 8"	39' 1"	34' 1"	28' 9"	36' 3"	31' 8"	26' 9"	34' 1"	29' 10"	25' 2"	32' 5"	28' 4"	23' 11"	31' 0"	27' 1"	22' 10"
	24	37' 7"	32' 10"	27' 8"	34' 1"	29' 10"	25' 2"	31' 8"	27' 8"	23' 4"	29' 10"	26' 0"	22' 0"	28' 4"	24' 9"	20' 10"	27' 1"	23' 8"	19' 11"
1000S200-43 ¹	12	33' 8" e	33' 0" e	27' 10"	29' 2" e	29' 2" e	25' 3" e	26' 1" e	26' 1" e	23' 5" e	23' 10" e	23' 10" e	22' 1" e	22' 0" e	22' 0" e	21' 0" e	20' 7" e	20' 7" e	20' 1" e
	16	29' 2" e	29' 2" e	25' 3" e	25' 3" e	25' 3" e	22' 11" e	22' 7" e	22' 7" e	21' 4" e	20' 7" e	20' 7" e	20' 1" e	19' 1" e	19' 1" e	19' 1" e	17' 10" e	17' 10" e	17' 10" e
	24	23' 10" e	23' 10" e	22' 1" e	20' 7" e	20' 7" e	20' 1" e	18' 5" e	18' 5" e	18' 5" e	16' 10" e	16' 10" e	16' 10" e	15' 7" e	15' 7" e	15' 7" e	14' 7" e	14' 7" e	14' 7" e
1000S200-54	12	40' 8"	35' 6"	30' 0"	36' 11"	32' 3"	27' 3"	34' 4"	30' 0"	25' 3"	31' 9"	28' 2"	23' 9"	29' 4"	26' 9"	22' 7"	27' 6" e	25' 7"	21' 7"
	16	36' 11"	32' 3"	27' 3"	33' 7"	29' 4"	24' 9"	30' 1"	27' 3"	23' 0"	27' 6" e	25' 7"	21' 7"	25' 5" e	24' 4" e	20' 6"	23' 9" e	23' 3" e	19' 8" e
	24	31' 9"	28' 2"	23' 9"	27' 6" e	25' 7"	21' 7"	24' 7" e	23' 9" e	20' 1"	22' 5" e	22' 5" e	18' 10" e	20' 9" e	20' 9" e	17' 11" e	19' 5" e	19' 5" e	17' 2" e
1000S200-68	12	44' 0"	38' 5"	32' 5"	40' 0"	34' 11"	29' 6"	37' 2"	32' 5"	27' 4"	34' 11"	30' 6"	25' 9"	33' 2"	29' 0"	24' 5"	31' 9"	27' 9"	23' 5"
	16	40' 0"	34' 11"	29' 6"	36' 4"	31' 9"	26' 9"	33' 9"	29' 6"	24' 10"	31' 9"	27' 9"	23' 5"	29' 11"	26' 4"	22' 3"	27' 11"	25' 2"	21' 3"
	24	34' 11"	30' 6"	25' 9"	31' 9"	27' 9"	23' 5"	28' 10"	25' 9"	21' 9"	26' 4"	24' 3"	20' 5"	24' 5" e	23' 0"	19' 5"	22' 10" e	22' 0" e	18' 7"
1000S200-97	12	49' 5"	43' 2"	36' 5"	44' 11"	39' 3"	33' 1"	41' 8"	36' 5"	30' 9"	39' 3"	34' 3"	28' 11"	37' 3"	32' 7"	27' 5"	35' 8"	31' 2"	26' 3"
	16	44' 11"	39' 3"	33' 1"	40' 10"	35' 8"	30' 1"	37' 10"	33' 1"	27' 11"	35' 8"	31' 2"	26' 3"	33' 10"	29' 7"	24' 11"	32' 5"	28' 3"	23' 10"
	24	39' 3"	34' 3"	28' 11"	35' 8"	31' 2"	26' 3"	33' 1"	28' 11"	24' 5"	31' 2"	27' 2"	22' 11"	29' 7"	25' 10"	21' 9"	28' 3"	24' 9"	20' 10"

See page 27 for clarification of code developed wind pressures prior to using this table.

Notes:

- Studs are checked for simple-span deflection and stress. Stress calculations are made for mid-span fully braced moment, end shear through the unperforated section and shear moment interaction through the perforated section 10' away from the end bearing.
- A 1/3 stress increase is not used.
- Limiting heights are based on continuous lateral support of each flange over the full height of the stud.
- Listed limiting heights are based on steel properties only.
- For bending, studs are assumed to be adequately braced to develop full allowable moment capacity. Stud distortional buckling based on an assumed $K\phi = 0$.
- Web crippling check based on 1-inch end bearing. Web stiffeners are required when listed limiting heights are followed by "e".
- Members marked with an ¹ have $h/t > 200$, and thus require end stiffeners.
- Capacities are calculated according to the AISI S100-16 (2020) w/S2-20. A 1-1/2" by 4" knockout spaced no closer than 24" o.c. is assumed. (3/4" for 2-1/2" studs)
- All values are based on $F_y=33\text{ksi}$ for 33mil and 43mil Studs, and $F_y=50\text{ksi}$ for 54mil, 68mil and 97mil Studs.
- For deflection calculations, 15psf and higher wind pressures have been multiplied by 0.7, in accordance with footnote "f" of IBC table 1604.3. The 5 psf pressure has not been reduced for deflection checks.
- Lateral loads have not been modified for strength checks. Full loads are applied.
- End reactions must be checked for web crippling separately.

Complies with AISI S100-16 (2020) w/S2-20 • IBC 2024

CURTAIN WALL HEIGHTS

Member	Spacing (in) o.c.	15psf			20psf			25psf			30psf			35psf			40psf		
		L/240	L/360	L/600	L/240	L/360	L/600	L/240	L/360	L/600	L/240	L/360	L/600	L/240	L/360	L/600	L/240	L/360	L/600
1000S250-43'	12	34' 8" e	34' 8" e	29' 5"	30' 0" e	30' 0" e	26' 9" e	26' 10" e	26' 10" e	24' 10" e	24' 6" e	24' 6" e	23' 4" e	22' 8" e	22' 8" e	22' 2" e	21' 3" e	21' 3" e	21' 3" e
	16	30' 0" e	30' 0" e	26' 9" e	26' 0" e	26' 0" e	24' 3" e	23' 3" e	23' 3" e	22' 7" e	21' 3" e	21' 3" e	21' 3" e	19' 8" e	19' 8" e	19' 8" e	18' 4" e	18' 4" e	18' 4" e
	24	24' 6" e	24' 6" e	23' 4" e	21' 3" e	21' 3" e	21' 3" e	19' 0" e	19' 0" e	19' 0" e	17' 4" e	17' 4" e	17' 4" e	16' 0" e	16' 0" e	16' 0" e	15' 0" e	15' 0" e	15' 0" e
1000S250-54	12	42' 11"	37' 6"	31' 7"	39' 0"	34' 1"	28' 9"	35' 8"	31' 7"	26' 8"	32' 7"	29' 9"	25' 1"	30' 2" e	28' 3"	23' 10"	28' 3" e	27' 0" e	22' 10"
	16	39' 0"	34' 1"	28' 9"	34' 7"	30' 11"	26' 1"	30' 11"	28' 9"	24' 3"	28' 3" e	27' 0" e	22' 10"	26' 2" e	25' 8" e	21' 8"	24' 5" e	24' 5" e	20' 9" e
	24	32' 7"	29' 9"	25' 1"	28' 3" e	27' 0" e	22' 10"	25' 3" e	25' 1" e	21' 2" e	23' 1" e	23' 1" e	19' 11" e	21' 4" e	21' 4" e	18' 11" e	19' 11" e	19' 11" e	18' 1" e
1000S250-68	12	46' 2"	40' 4"	34' 0"	41' 11"	36' 8"	30' 11"	38' 11"	34' 0"	28' 8"	36' 8"	32' 0"	27' 0"	34' 10"	30' 5"	25' 8"	33' 2"	29' 1"	24' 6"
	16	41' 11"	36' 8"	30' 11"	38' 1"	33' 3"	28' 1"	35' 4"	30' 11"	26' 1"	33' 2"	29' 1"	24' 6"	30' 9"	27' 7"	23' 4"	28' 9"	26' 5"	22' 3"
	24	36' 8"	32' 0"	27' 0"	33' 2"	29' 1"	24' 6"	29' 8"	27' 0"	22' 9"	27' 1" e	25' 5"	21' 5"	25' 1" e	24' 1" e	20' 4"	23' 6" e	23' 1" e	19' 6"
1000S250-97	12	51' 6"	44' 11"	37' 11"	46' 9"	40' 10"	34' 5"	43' 5"	37' 11"	32' 0"	40' 10"	35' 8"	30' 1"	38' 10"	33' 11"	28' 7"	37' 1"	32' 5"	27' 4"
	16	46' 9"	40' 10"	34' 5"	42' 6"	37' 1"	31' 4"	39' 5"	34' 5"	29' 1"	37' 1"	32' 5"	27' 4"	35' 3"	30' 10"	26' 0"	33' 9"	29' 5"	24' 10"
	24	40' 10"	35' 8"	30' 1"	37' 1"	32' 5"	27' 4"	34' 5"	30' 1"	25' 5"	32' 5"	28' 4"	23' 11"	30' 10"	26' 11"	22' 8"	29' 5"	25' 9"	21' 8"
1000S300-54	12	43' 9"	38' 3"	32' 3"	39' 9"	34' 9"	29' 4"	36' 3"	32' 3"	27' 2"	33' 1"	30' 4"	25' 7"	30' 8" e	28' 10"	24' 4"	28' 8" e	27' 7" e	23' 3"
	16	39' 9"	34' 9"	29' 4"	35' 1"	31' 7"	26' 8"	31' 5" e	29' 4"	24' 9"	28' 8" e	27' 7" e	23' 3"	26' 7" e	26' 2" e	22' 1"	24' 10" e	24' 10" e	21' 2" e
	24	33' 1"	30' 4"	25' 7"	28' 8" e	27' 7" e	23' 3"	25' 8" e	25' 7" e	21' 7" e	23' 5" e	23' 5" e	20' 4" e	21' 8" e	21' 8" e	19' 4" e	20' 3" e	20' 3" e	18' 6" e
1000S300-68	12	47' 5"	41' 5"	34' 11"	43' 1"	37' 8"	31' 9"	40' 0"	34' 11"	29' 6"	37' 8"	32' 11"	27' 9"	35' 9"	31' 3"	26' 4"	33' 9"	29' 11"	25' 2"
	16	43' 1"	37' 8"	31' 9"	39' 2"	34' 3"	28' 10"	36' 4"	31' 9"	26' 9"	33' 9"	29' 11"	25' 2"	31' 3"	28' 5"	23' 11"	29' 3"	27' 2"	22' 11"
	24	37' 8"	32' 11"	27' 9"	33' 9"	29' 11"	25' 2"	30' 2"	27' 9"	23' 5"	27' 7" e	26' 1"	22' 0"	25' 6" e	24' 10" e	20' 11"	23' 10" e	23' 9" e	20' 0"
1000S300-97	12	53' 1"	46' 5"	39' 1"	48' 3"	42' 2"	35' 7"	44' 9"	39' 1"	33' 0"	42' 2"	36' 10"	31' 1"	40' 0"	35' 0"	29' 6"	38' 3"	33' 5"	28' 3"
	16	48' 3"	42' 2"	35' 7"	43' 10"	38' 3"	32' 4"	40' 8"	35' 7"	30' 0"	38' 3"	33' 5"	28' 3"	36' 4"	31' 9"	26' 10"	34' 9"	30' 5"	25' 8"
	24	42' 2"	36' 10"	31' 1"	38' 3"	33' 5"	28' 3"	35' 7"	31' 1"	26' 2"	33' 5"	29' 3"	24' 8"	31' 9"	27' 9"	23' 5"	30' 5"	26' 7"	22' 5"

See page 27 for clarification of code developed wind pressures prior to using this table.

Notes:

- Studs are checked for simple-span deflection and stress. Stress calculations are made for mid-span fully braced moment, end shear through the unperforated section and shear moment interaction through the perforated section 10" away from the end bearing.
- A 1/3 stress increase is not used.
- Limiting heights are based on continuous lateral support of each flange over the full height of the stud.
- Listed limiting heights are based on steel properties only.
- For bending, studs are assumed to be adequately braced to develop full allowable moment capacity. Stud distortional buckling based on an assumed $K\phi = 0$.
- Web crippling check based on 1-inch end bearing. Web stiffeners are required when listed limiting heights are followed by "e".
- Members marked with an ¹ have $h/t > 200$, and thus require end stiffeners.
- Capacities are calculated according to the AISI S100-16 (2020) w/S2-20. A 1-1/2" by 4" knockout spaced no closer than 24" o.c. is assumed. (3/4" for 2-1/2" studs)
- All values are based on $F_y=33\text{ksi}$ for 33mil and 43mil Studs, and $F_y=50\text{ksi}$ for 54mil, 68mil and 97mil Studs.
- For deflection calculations, 15psf and higher wind pressures have been multiplied by 0.7, in accordance with footnote "f" of IBC table 1604.3. The 5 psf pressure has not been reduced for deflection checks.
- Lateral loads have not been modified for strength checks. Full loads are applied.
- End reactions must be checked for web crippling separately.

Complies with AISI S100-16 (2020) w/S2-20 • IBC 2024

CURTAIN WALL HEIGHTS

Member	Spacing (in) o.c.	15psf			20psf			25psf			30psf			35psf			40psf		
		L/240	L/360	L/600	L/240	L/360	L/600	L/240	L/360	L/600	L/240	L/360	L/600	L/240	L/360	L/600	L/240	L/360	L/600
1200S162-54 ¹	12	44' 8"	39' 1"	32' 11"	38' 10"	35' 6"	29' 11"	34' 9"	32' 11"	27' 9"	31' 8"	31' 0"	26' 2"	29' 4" e	29' 4" e	24' 10"	27' 5" e	27' 5" e	23' 9"
	16	38' 10"	35' 6"	29' 11"	33' 7"	32' 3"	27' 2"	30' 1"	29' 11"	25' 3"	27' 5" e	27' 5" e	23' 9"	25' 5" e	25' 5" e	22' 7" e	23' 9" e	23' 9" e	21' 7" e
	24	31' 8"	31' 0"	26' 2"	27' 5" e	27' 5" e	27' 5" e	24' 7" e	24' 7" e	22' 1" e	22' 5" e	22' 5" e	20' 9" e	20' 9" e	20' 9" e	19' 8" e	19' 5" e	19' 5" e	18' 10" e
1200S162-68	12	48' 7"	42' 6"	35' 10"	44' 2"	38' 7"	32' 6"	41' 0"	35' 10"	30' 2"	37' 8"	33' 8"	28' 5"	34' 10"	32' 0"	27' 0"	32' 7"	30' 7"	25' 10"
	16	44' 2"	38' 7"	32' 6"	39' 11"	35' 1"	29' 7"	35' 8"	32' 6"	27' 5"	32' 7"	30' 7"	25' 10"	30' 2"	29' 1"	24' 6"	28' 3"	27' 10"	23' 6"
	24	37' 8"	33' 8"	28' 5"	32' 7"	30' 7"	25' 10"	29' 2"	28' 5"	24' 0"	26' 7" e	26' 7" e	22' 7"	24' 8" e	24' 8" e	21' 5"	23' 0" e	23' 0" e	20' 6" e
1200S162-97	12	55' 1"	48' 1"	40' 7"	50' 0"	43' 8"	36' 10"	46' 5"	40' 7"	34' 3"	43' 8"	38' 2"	32' 2"	41' 6"	36' 3"	30' 7"	39' 8"	34' 8"	29' 3"
	16	50' 0"	43' 8"	36' 10"	45' 5"	39' 8"	33' 6"	42' 2"	36' 10"	31' 1"	39' 8"	34' 8"	29' 3"	37' 9"	32' 11"	27' 9"	36' 1"	31' 6"	26' 7"
	24	43' 8"	38' 2"	32' 2"	39' 8"	34' 8"	29' 3"	36' 10"	32' 2"	27' 2"	34' 5"	30' 4"	25' 7"	31' 10"	28' 9"	24' 3"	29' 10"	27' 6"	23' 3"
1200S200-54 ¹	12	46' 9"	40' 10"	34' 5"	42' 2"	37' 1"	31' 3"	37' 8"	34' 5"	29' 0"	34' 5" e	32' 5"	27' 4"	31' 10" e	30' 9" e	25' 11"	29' 10" e	29' 5" e	24' 10"
	16	42' 2"	37' 1"	31' 3"	36' 6"	33' 8"	28' 5"	32' 8" e	31' 3" e	26' 5"	29' 10" e	29' 5" e	24' 10"	27' 7" e	27' 7" e	23' 7" e	25' 10" e	25' 10" e	22' 7" e
	24	34' 5" e	32' 5"	27' 4"	29' 10" e	29' 5" e	24' 10"	26' 8" e	26' 8" e	23' 1" e	24' 4" e	24' 4" e	21' 8" e	22' 6" e	22' 6" e	20' 7" e	21' 1" e	21' 1" e	19' 8" e
1200S200-68	12	50' 8"	44' 3"	37' 4"	46' 1"	40' 3"	33' 11"	42' 9"	37' 4"	31' 6"	40' 3"	35' 2"	28' 7"	37' 8"	33' 5"	28' 2"	35' 2"	31' 11"	26' 11"
	16	46' 1"	40' 3"	33' 11"	41' 10"	36' 7"	30' 10"	38' 7"	33' 11"	28' 7"	35' 2"	31' 11"	26' 11"	32' 7"	30' 4"	25' 7"	30' 6" e	29' 0"	24' 6"
	24	40' 3"	35' 2"	29' 8"	35' 2"	31' 11"	26' 11"	31' 6" e	29' 8"	25' 0"	28' 9" e	27' 11" e	23' 6"	26' 7" e	26' 6" e	22' 4"	24' 11" e	24' 11" e	21' 5" e
1200S200-97	12	57' 4"	50' 1"	42' 3"	52' 1"	45' 6"	38' 5"	48' 4"	42' 3"	35' 8"	45' 6"	39' 9"	33' 6"	43' 3"	37' 9"	31' 10"	41' 4"	36' 1"	30' 6"
	16	52' 1"	45' 6"	38' 5"	47' 4"	41' 4"	34' 10"	43' 11"	38' 5"	32' 4"	41' 4"	36' 1"	30' 6"	39' 3"	34' 4"	28' 11"	37' 7"	32' 10"	27' 8"
	24	45' 6"	39' 9"	33' 6"	41' 4"	36' 1"	30' 6"	38' 5"	33' 6"	28' 3"	36' 1"	31' 7"	26' 7"	34' 2"	30' 0"	25' 3"	32' 0"	28' 8"	24' 2"
1200S250-54 ¹	12	48' 8"	42' 6"	35' 10"	43' 7"	38' 7"	32' 7"	38' 11"	35' 10"	30' 3"	35' 7" e	33' 9" e	28' 5"	32' 11" e	32' 0" e	27' 0"	30' 10" e	30' 8" e	25' 10" e
	16	43' 7"	38' 7"	32' 7"	37' 9"	35' 1"	29' 7"	33' 9" e	32' 7" e	27' 6"	30' 10" e	30' 8" e	25' 10" e	28' 6" e	28' 6" e	24' 7" e	26' 8" e	26' 8" e	23' 6" e
	24	35' 7" e	33' 9" e	28' 5"	30' 10" e	30' 8" e	25' 10" e	27' 7" e	27' 7" e	24' 0" e	25' 2" e	25' 2" e	22' 7" e	23' 3" e	23' 3" e	21' 5" e	21' 9" e	21' 9" e	20' 6" e
1200S250-68	12	52' 10"	46' 1"	38' 11"	48' 0"	41' 11"	35' 4"	44' 6"	38' 11"	32' 10"	41' 11"	36' 7"	30' 11"	38' 10"	34' 9"	29' 4"	36' 4"	33' 3"	28' 1"
	16	48' 0"	41' 11"	35' 4"	43' 7"	38' 1"	32' 1"	39' 10"	35' 4"	29' 10"	36' 4"	33' 3"	28' 1"	33' 8" e	31' 7"	26' 8"	31' 6" e	30' 3" e	25' 6"
	24	41' 11"	36' 7"	30' 11"	36' 4"	33' 3"	28' 1"	32' 6" e	30' 11"	26' 1"	29' 8" e	29' 1" e	24' 6"	27' 6" e	27' 6" e	23' 3" e	25' 9" e	25' 9" e	22' 3" e
1200S250-97	12	59' 7"	52' 0"	43' 11"	54' 1"	47' 3"	39' 10"	50' 3"	43' 11"	37' 0"	47' 3"	41' 4"	34' 10"	44' 11"	39' 3"	33' 1"	42' 11"	37' 6"	31' 8"
	16	54' 1"	47' 3"	39' 10"	49' 2"	42' 11"	36' 3"	45' 8"	39' 10"	33' 8"	42' 11"	37' 6"	30' 1"	40' 10"	35' 8"	30' 1"	39' 0"	34' 1"	28' 9"
	24	47' 3"	41' 4"	34' 10"	42' 11"	37' 6"	31' 8"	39' 10"	34' 10"	29' 5"	37' 6"	32' 9"	27' 8"	35' 4"	31' 2"	26' 3"	33' 1"	29' 9"	25' 1"
1200S300-54 ¹	12	50' 10"	44' 5"	37' 5"	44' 5"	40' 4"	34' 0"	39' 9"	37' 5"	31' 7"	36' 3" e	35' 3" e	29' 9"	33' 7" e	33' 6" e	28' 3"	31' 5" e	31' 5" e	27' 0" e
	16	44' 5"	40' 4"	34' 0"	38' 5" e	36' 8"	30' 11"	34' 5" e	34' 0" e	28' 8"	31' 5" e	31' 5" e	27' 0" e	29' 1" e	29' 1" e	25' 8" e	27' 2" e	27' 2" e	24' 7" e
	24	36' 3" e	35' 3" e	29' 9"	31' 5" e	31' 5" e	27' 0" e	28' 1" e	28' 1" e	25' 1" e	25' 8" e	25' 8" e	23' 7" e	23' 9" e	23' 9" e	22' 5" e	22' 2" e	22' 2" e	21' 5" e
1200S300-68	12	54' 11"	48' 0"	40' 5"	49' 11"	43' 7"	36' 9"	46' 4"	40' 5"	34' 1"	42' 10"	38' 1"	32' 1"	39' 8"	36' 2"	30' 6"	37' 1"	34' 7"	29' 2"
	16	49' 11"	43' 7"	36' 9"	45' 4"	39' 7"	33' 5"	40' 7"	36' 9"	31' 0"	37' 1"	34' 7"	29' 2"	34' 4" e	32' 10"	27' 9"	32' 1" e	31' 5" e	26' 6"
	24	42' 10"	38' 1"	32' 1"	37' 1"	34' 7"	29' 2"	33' 2" e	32' 1" e	27' 1"	30' 3" e	30' 3" e	25' 6"	28' 0" e	28' 0" e	24' 2" e	26' 3" e	26' 3" e	23' 2" e
1200S300-97	12	61' 5"	53' 8"	45' 3"	55' 9"	48' 9"	41' 1"	51' 10"	45' 3"	38' 2"	48' 9"	42' 7"	35' 11"	46' 4"	40' 5"	34' 1"	44' 3"	38' 8"	32' 8"
	16	55' 9"	48' 9"	41' 1"	50' 8"	44' 3"	37' 4"	47' 1"	41' 1"	34' 8"	44' 3"	38' 8"	32' 8"	42' 1"	36' 9"	31' 0"	40' 3"	35' 2"	29' 8"
	24	48' 9"	42' 7"	35' 11"	44' 3"	38' 8"	32' 8"	41' 1"	35' 11"	30' 3"	38' 8"	33' 10"	28' 6"	36' 1"	32' 1"	27' 1"	33' 9"	30' 8"	25' 11"

See page 27 for clarification of code developed wind pressures prior to using this table.

Notes:

- 1 Studs are checked for simple-span deflection and stress. Stress calculations are made for mid-span fully braced moment, end shear through the unperforated section and shear moment interaction through the perforated section 10" away from the end bearing.
- 2 A 1/3 stress increase is not used.
- 3 Limiting heights are based on continuous lateral support of each flange over the full height of the stud.
- 4 Listed limiting heights are based on steel properties only.
- 5 For bending, studs are assumed to be adequately braced to develop full allowable moment capacity. Stud distortional buckling based on an assumed $K\phi = 0$.
- 6 Web crippling check based on 1-inch end bearing. Web stiffeners are required when listed limiting heights are followed by "e".
- 7 Members marked with an ¹ have h/t > 200, and thus require end stiffeners.
- 8 Capacities are calculated according to the AISI S100-16 (2020) w/S2-20. A 1-1/2" by 4" knockout spaced no closer than 24" o.c. is assumed. (3/4" for 2-1/2" studs)
- 9 All values are based on $F_y=33$ ksi for 33mil and 43mil Studs, and $F_y=50$ ksi for 54mil, 68mil and 97mil Studs.
- 10 For deflection calculations, 15psf and higher wind pressures have been multiplied by 0.7, in accordance with footnote "f" of IBC table 1604.3. The 5 psf pressure has not been reduced for deflection checks.
- 11 Lateral loads have not been modified for strength checks. Full loads are applied.
- 12 End reactions must be checked for web crippling separately.

Complies with AISI S100-16 (2020) w/S2-20 • IBC 2024

The technical content of this literature is effective 06/01/24 and supersedes all previous information.

CURTAIN WALL HEIGHTS

Member	Spacing (in) o.c.	15psf			20psf			25psf			30psf			35psf			40psf		
		L/240	L/360	L/600	L/240	L/360	L/600	L/240	L/360	L/600	L/240	L/360	L/600	L/240	L/360	L/600	L/240	L/360	L/600
1400S162-54 ¹	12	47' 5"	43' 11"	37' 1"	41' 0"	39' 11"	33' 8"	36' 8"	36' 8"	31' 3"	33' 6" e	33' 6" e	29' 5"	31' 0" e	31' 0" e	27' 11" e	29' 0" e	29' 0" e	26' 9" e
	16	41' 0"	39' 11"	33' 8"	35' 6"	35' 6"	30' 7"	31' 9" e	31' 9" e	28' 5"	29' 0" e	29' 0" e	26' 9" e	26' 10" e	26' 10" e	25' 5" e	25' 1" e	25' 1" e	24' 3" e
	24	33' 6" e	33' 6" e	29' 5"	29' 0" e	29' 0" e	26' 9" e	25' 11" e	25' 11" e	24' 10" e	23' 8" e	23' 8" e	23' 4" e	21' 11" e	21' 11" e	20' 6" e	20' 6" e	20' 6" e	20' 6" e
1400S162-68	12	54' 10"	47' 11"	40' 5"	48' 11"	43' 6"	36' 8"	43' 9"	40' 5"	34' 1"	40' 0"	38' 0"	32' 1"	37' 0"	36' 1"	30' 5"	34' 7"	34' 6"	29' 1"
	16	48' 11"	43' 6"	36' 8"	42' 5"	39' 6"	33' 4"	37' 11"	36' 8"	30' 11"	34' 7"	34' 6"	29' 1"	32' 1"	32' 1"	27' 8"	30' 0" e	30' 0" e	26' 6"
	24	40' 0"	38' 0"	32' 1"	34' 7"	34' 6"	29' 1"	31' 0" e	31' 0" e	27' 0"	28' 3" e	28' 3" e	25' 5" e	26' 2" e	26' 2" e	24' 2" e	24' 6" e	24' 6" e	23' 1" e
1400S162-97	12	62' 5"	54' 6"	46' 0"	56' 8"	49' 6"	41' 9"	52' 7"	46' 0"	38' 9"	49' 6"	43' 3"	36' 6"	47' 0"	41' 1"	34' 8"	45' 0"	39' 4"	33' 2"
	16	56' 8"	49' 6"	41' 9"	51' 6"	45' 0"	37' 11"	47' 10"	41' 9"	35' 3"	45' 0"	39' 4"	33' 2"	41' 10"	37' 4"	31' 6"	39' 1"	35' 9"	30' 1"
	24	49' 6"	43' 3"	36' 6"	45' 0"	39' 4"	33' 2"	40' 5"	36' 6"	30' 9"	36' 11"	34' 4"	29' 0"	34' 2"	32' 7"	27' 6"	31' 11"	31' 2"	26' 4"
1400S200-54 ¹	12	51' 9"	45' 11"	38' 8"	44' 9"	41' 8"	35' 2"	40' 1" e	38' 8"	32' 8"	36' 7" e	36' 5" e	30' 9"	33' 10" e	33' 10" e	29' 2" e	31' 8" e	31' 8" e	27' 11" e
	16	44' 9"	41' 8"	35' 2"	38' 9" e	37' 10" e	31' 11"	34' 8" e	34' 8" e	29' 8" e	31' 8" e	31' 8" e	27' 11" e	29' 4" e	29' 4" e	26' 6" e	27' 5" e	27' 5" e	25' 4" e
	24	36' 7" e	36' 5" e	30' 9"	31' 8" e	31' 8" e	27' 11" e	28' 4" e	28' 4" e	25' 11" e	25' 10" e	25' 10" e	24' 5" e	23' 11" e	23' 11" e	23' 2" e	22' 5" e	22' 5" e	22' 2" e
1400S200-68	12	57' 1"	49' 10"	42' 1"	51' 10"	45' 4"	38' 3"	47' 7"	42' 1"	35' 6"	43' 5"	39' 7"	33' 5"	40' 2"	37' 7"	31' 9"	37' 7"	36' 0"	30' 4"
	16	51' 10"	45' 4"	38' 3"	46' 0"	41' 2"	34' 9"	41' 2"	38' 3"	32' 3"	37' 7"	36' 0"	30' 4"	34' 10" e	34' 2" e	28' 10"	32' 7" e	32' 7" e	27' 7"
	24	43' 5"	39' 7"	33' 5"	37' 7"	36' 0"	30' 4"	33' 7" e	33' 5" e	28' 2"	30' 8" e	30' 8" e	26' 6" e	28' 5" e	28' 5" e	25' 2" e	26' 7" e	26' 7" e	24' 1" e
1400S200-97	12	64' 10"	56' 7"	47' 9"	58' 11"	51' 5"	43' 5"	47' 9"	40' 3"	51' 5"	44' 11"	37' 11"	48' 10"	42' 8"	36' 0"	46' 9"	40' 10"	34' 5"	31' 3"
	16	58' 11"	51' 5"	43' 5"	53' 6"	46' 9"	39' 5"	49' 8"	43' 5"	36' 7"	46' 9"	40' 10"	34' 5"	44' 5"	38' 9"	32' 9"	42' 2"	37' 1"	31' 3"
	24	51' 5"	44' 11"	37' 11"	46' 9"	40' 10"	34' 5"	43' 5"	37' 11"	32' 0"	39' 9"	35' 8"	30' 1"	36' 10"	33' 11"	28' 7"	34' 5"	32' 5"	27' 4"
1400S250-54 ¹	12	53' 9"	47' 9"	40' 3"	46' 7"	43' 5"	36' 7"	41' 8" e	40' 3" e	34' 0"	38' 0" e	37' 11" e	32' 0"	35' 2" e	35' 2" e	30' 4" e	32' 11" e	32' 11" e	29' 0" e
	16	46' 7"	43' 5"	36' 7"	40' 4" e	39' 5" e	33' 3"	36' 1" e	36' 1" e	30' 10" e	32' 11" e	32' 11" e	29' 0" e	30' 6" e	30' 6" e	27' 7" e	28' 6" e	28' 6" e	26' 5" e
	24	38' 0" e	37' 11" e	32' 0"	32' 11" e	32' 11" e	29' 0" e	29' 5" e	29' 5" e	26' 11" e	26' 11" e	26' 11" e	25' 4" e	24' 11" e	24' 11" e	24' 1" e	23' 3" e	23' 3" e	23' 1" e
1400S250-68	12	59' 5"	51' 11"	43' 9"	54' 0"	47' 2"	39' 9"	49' 4"	43' 9"	36' 11"	45' 1"	41' 2"	34' 9"	41' 9"	39' 1"	33' 0"	39' 0" e	37' 5"	31' 7"
	16	54' 0"	47' 2"	39' 9"	47' 10"	42' 10"	36' 2"	42' 9"	39' 9"	33' 6"	39' 0" e	37' 5"	31' 7"	36' 2" e	35' 7" e	30' 0"	33' 10" e	33' 10" e	28' 8" e
	24	45' 1"	41' 2"	34' 9"	39' 0" e	37' 5"	31' 7"	34' 11" e	34' 9" e	29' 4"	31' 10" e	31' 10" e	27' 7" e	29' 6" e	29' 6" e	26' 2" e	27' 7" e	27' 7" e	25' 1" e
1400S250-97	12	67' 3"	58' 9"	49' 6"	61' 1"	53' 4"	45' 0"	56' 8"	49' 6"	41' 9"	53' 4"	46' 7"	39' 4"	50' 8"	44' 3"	37' 4"	48' 6"	42' 4"	35' 9"
	16	61' 1"	53' 4"	45' 0"	55' 6"	48' 6"	40' 11"	51' 6"	45' 0"	37' 11"	48' 6"	42' 4"	35' 9"	46' 1"	40' 3"	33' 11"	43' 9"	38' 6"	32' 5"
	24	53' 4"	46' 7"	39' 4"	48' 6"	42' 4"	35' 9"	45' 0"	39' 4"	33' 2"	41' 3"	37' 0"	31' 2"	38' 2"	35' 2"	29' 8"	35' 9"	33' 7"	28' 4"
1400S300-54 ¹	12	55' 1"	48' 5"	40' 10"	47' 8"	44' 0"	37' 1"	42' 8" e	40' 10" e	34' 5"	38' 11" e	38' 5" e	32' 5"	36' 1" e	36' 1" e	30' 9" e	33' 9" e	33' 9" e	29' 5" e
	16	47' 8"	44' 0"	37' 1"	41' 4" e	39' 11" e	33' 8"	36' 11" e	36' 11" e	31' 3" e	33' 9" e	33' 9" e	29' 5" e	31' 3" e	31' 3" e	28' 0" e	29' 2" e	29' 2" e	26' 9" e
	24	38' 11" e	38' 5" e	32' 5"	33' 9" e	33' 9" e	29' 5" e	30' 2" e	30' 2" e	27' 4" e	27' 6" e	27' 6" e	25' 9" e	25' 6" e	25' 6" e	24' 5" e	23' 10" e	23' 10" e	23' 4" e
1400S300-68	12	61' 0"	53' 3"	44' 11"	55' 5"	48' 5"	40' 10"	50' 6"	44' 11"	37' 11"	46' 2"	42' 3"	35' 8"	42' 9"	40' 2"	33' 10"	39' 11" e	38' 5" e	32' 5"
	16	55' 5"	48' 5"	40' 10"	48' 11"	44' 0"	37' 1"	43' 9"	40' 10"	34' 5"	39' 11" e	38' 5" e	32' 5"	37' 0" e	36' 6" e	30' 9"	34' 7" e	34' 7" e	29' 5" e
	24	46' 2"	42' 3"	35' 8"	39' 11" e	38' 5" e	32' 5"	35' 9" e	35' 8" e	30' 1"	32' 7" e	32' 7" e	28' 4" e	30' 2" e	30' 2" e	26' 11" e	28' 3" e	28' 3" e	25' 9" e
1400S300-97	12	69' 3"	60' 6"	51' 0"	62' 11"	55' 0"	46' 4"	58' 5"	51' 0"	43' 1"	55' 0"	48' 0"	40' 6"	52' 3"	45' 7"	38' 6"	49' 11"	43' 8"	36' 10"
	16	62' 11"	55' 0"	46' 4"	57' 2"	49' 11"	42' 2"	53' 1"	46' 4"	39' 1"	49' 11"	43' 8"	36' 10"	47' 5"	41' 5"	35' 0"	44' 10"	39' 8"	33' 5"
	24	55' 0"	48' 0"	40' 6"	49' 11"	43' 8"	36' 10"	46' 3"	40' 6"	34' 2"	42' 3"	38' 1"	32' 2"	39' 1"	36' 3"	30' 6"	36' 7"	34' 8"	29' 3"

See page 27 for clarification of code developed wind pressures prior to using this table.

Notes:

- Studs are checked for simple-span deflection and stress. Stress calculations are made for mid-span fully braced moment, end shear through the unperforated section and shear moment interaction through the perforated section 10" away from the end bearing.
- A 1/3 stress increase is not used.
- Limiting heights are based on continuous lateral support of each flange over the full height of the stud.
- Listed limiting heights are based on steel properties only.
- For bending, studs are assumed to be adequately braced to develop full allowable moment capacity. Stud distortional buckling based on an assumed $K\phi = 0$.
- Web crippling check based on 1-inch end bearing. Web stiffeners are required when listed limiting heights are followed by "e".
- Members marked with an ¹ have $h/t > 200$, and thus require end stiffeners.
- Capacities are calculated according to the AISI S100-16 (2020) w/S2-20. A 1-1/2" by 4" knockout spaced no closer than 24" o.c. is assumed. (3/4" for 2-1/2" studs)
- All values are based on $F_y = 33 \text{ksi}$ for 33mil and 43mil Studs, and $F_y = 50 \text{ksi}$ for 54mil, 68mil and 97mil Studs.
- For deflection calculations, 15psf and higher wind pressures have been multiplied by 0.7, in accordance with footnote "f" of IBC table 1604.3. The 5 psf pressure has not been reduced for deflection checks.
- Lateral loads have not been modified for strength checks. Full loads are applied.
- End reactions must be checked for web crippling separately.

Complies with AISI S100-16 (2020) w/S2-20 • IBC 2024



ALLOWABLE AXIAL & LATERAL LOAD TABLES

Allowable combined axial & lateral loads.

Load-bearing walls must be capable of handling vertical loads even when subjected to lateral loads from wind or another force. The following tables identify the axial (vertical) load that can be supported by each member under given lateral load conditions.

General Notes:

- 1 Allowable axial loads listed in kips (1 kip = 1000 pounds).
- 2 Allowable axial loads determined in accordance with AISI S100-16 (2020) w/S2-20 and assuming that all axial loads pass through centroid of effective section.
- 3 Listed lateral pressures and axial loads have not been modified for 1/3 stress increase based on wind/earthquake or multiple transient loads.
- 4 For material thickness of 33mil and 43mil, $F_y = 33\text{ksi}$, for 54mil and thicker, $F_y = 50\text{ksi}$.
- 5 Allowable loads based on weak axis and torsional horizontal mechanical bracing at 48" o.c. maximum for axial load calculations and continuous support for each flange for flexural calculations.
- 6 For deflection calculations, the 15 psf and higher ASD wind pressures have been multiplied by .7, in accordance with footnote "f" of IBC table 1604.3. The 5 psf pressure has not been reduced for deflection checks. (See example on page 27)
- 7 Studs are assumed to be adequately braced at a maximum spacing of L_u to develop full allowable moment, M_a .
- 8 Listed tables are based on simple (single) span.
- 9 Stud distortional buckling based on an assumed $K\phi = 0$.
- 10 The strength increase due to cold work of forming was incorporated for flexural strength as applicable per AISI S100-16 (2020) w/S2-20.
- 11 The allowable axial loads do not include the effects of the gypsum board.
- 12 Cells marked with an a, b, c, d, e, or f meet L/720, L/600, L/480, L/360, L/240, or L/120 respectively. Blank cells do not meet L/120. For deflection calculations, lateral loads are multiplied by 0.7 per AISI S240 except for 5psf load which is considered interior wall load.
- 13 Cells marked with an "*" have $h/t > 200$, and thus require bearing stiffeners. Cells are left blank when $h/t > 260$.

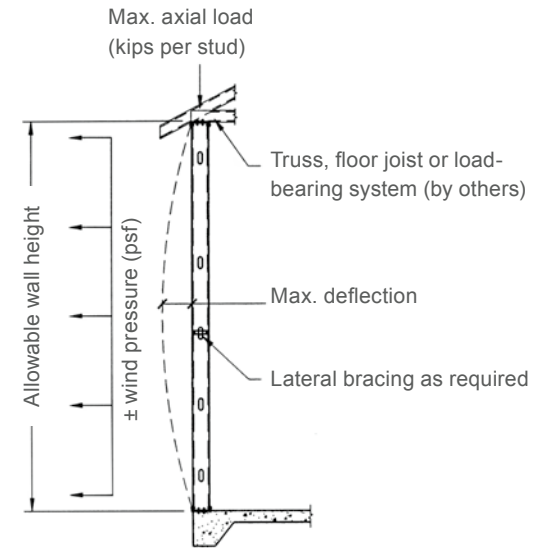

Complies with AISI S100-16 (2020) w/S2-20 • IBC 2024

ALLOWABLE COMBINED AXIAL & LATERAL LOADS (Kips/Stud)

Wind = 5psf		S162 (1-5/8" Flange)					S200 (2" Flange)					S250 (2-1/2" Flange)				
Stud length (ft)	Spacing (in) o.c.	-33	-43	-54	-68	-97	-33	-43	-54	-68	-97	-43	-54	-68	-97	
		(20ga) 33ksi	(18ga) 33ksi	(16ga) 50ksi	(14ga) 50ksi	(12ga) 50ksi	(20ga) 33ksi	(18ga) 33ksi	(16ga) 50ksi	(14ga) 50ksi	(12ga) 50ksi	(18ga) 33ksi	(16ga) 50ksi	(14ga) 50ksi	(12ga) 50ksi	
3-5/8" Stud	8	12	1.87 a	2.64 a	4.15 a	5.38 a	7.86 a	2.25 a	3.28 a	5.18 a	6.68 a	9.53 a	3.71 a	5.82 a	7.76 a	11.03 a
		16	1.79 a	2.57 a	4.07 a	5.31 a	7.78 a	2.17 a	3.20 a	5.10 a	6.60 a	9.45 a	3.62 a	5.73 a	7.67 a	10.95 a
		24	1.64 a	2.42 a	3.93 a	5.16 a	7.62 a	2.01 a	3.03 a	4.94 a	6.44 a	9.29 a	3.45 a	5.56 a	7.50 a	10.80 a
	9	12	1.73 a	2.48 a	3.85 a	4.98 a	7.27 a	2.10 a	3.07 a	4.79 a	6.16 a	8.80 a	3.52 a	5.46 a	7.17 a	10.21 a
		16	1.64 a	2.38 a	3.76 a	4.89 a	7.17 a	2.00 a	2.96 a	4.69 a	6.06 a	8.70 a	3.40 a	5.35 a	7.06 a	10.11 a
		24	1.45 a	2.19 a	3.58 a	4.71 a	6.97 a	1.80 a	2.76 a	4.49 a	5.87 a	8.50 a	3.18 a	5.14 a	6.85 a	9.91 a
	10	12	1.58 a	2.29 a	3.52 a	4.54 a	6.62 a	1.93 a	2.84 a	4.37 a	5.61 a	8.01 a	3.29 a	5.08 a	6.54 a	9.33 a
		16	1.46 a	2.17 a	3.41 a	4.43 a	6.49 a	1.81 a	2.71 a	4.25 a	5.49 a	7.89 a	3.15 a	4.95 a	6.40 a	9.21 a
		24	1.25 a	1.95 a	3.20 a	4.22 a	6.26 a	1.57 a	2.47 a	4.01 a	5.26 a	7.65 a	2.89 a	4.69 a	6.15 a	8.97 a
	12	12	1.25 a	1.86 a	2.78 a	3.59 a	5.22 a	1.56 a	2.32 a	3.45 a	4.44 a	6.36 a	2.74 a	4.06 a	5.21 a	7.49 a
		16	1.11 a	1.71 a	2.65 a	3.46 a	5.07 a	1.40 a	2.16 a	3.30 a	4.29 a	6.20 a	2.55 a	3.90 a	5.05 a	7.34 a
		24	0.85 c	1.44 b	2.40 a	3.21 a	4.79 a	1.11 c	1.86 a	3.03 a	4.02 a	5.91 a	2.22 a	3.59 a	4.74 a	7.04 a
14	12	0.92 b	1.44 a	2.13 a	2.77 a	4.02 a	1.18 a	1.81 a	2.64 a	3.43 a	4.93 a	2.15 a	3.12 a	4.05 a	5.87 a	
	16	0.77 d	1.27 b	1.99 a	2.63 a	3.86 a	1.01 c	1.63 b	2.48 a	3.27 a	4.76 a	1.95 a	2.94 a	3.87 a	5.70 a	
	24	0.51 e	0.98 d	1.73 c	2.37 b	3.56 a	0.70 d	1.31 d	2.19 c	2.98 a	4.45 a	1.59 c	2.62 b	3.54 a	5.37 a	
16	12	0.65 d	1.06 c	1.62 b	2.14 a	3.11 a	0.84 c	1.36 b	2.01 a	2.65 a	3.84 a	1.63 a	2.40 a	3.15 a	4.62 a	
	16	0.50 e	0.90 d	1.48 c	1.99 b	2.94 a	0.67 d	1.18 c	1.86 c	2.49 a	3.67 a	1.42 c	2.22 b	2.96 a	4.44 a	
	24	0.24 f	0.61 e	1.23 e	1.73 d	2.65 c	0.38 e	0.86 e	1.58 d	2.21 c	3.36 b	1.06 d	1.90 d	2.64 c	4.11 a	
4" Stud	8	12	2.03 a	2.87 a	4.61 a	6.18 a	9.08 a	2.42 a	3.55 a	5.77 a	7.63 a	11.03 a	3.97 a	6.28 a	8.68 a	12.76 a
		16	1.96 a	2.80 a	4.54 a	6.11 a	9.00 a	2.34 a	3.47 a	5.70 a	7.55 a	10.95 a	3.89 a	6.20 a	8.60 a	12.69 a
		24	1.81 a	2.65 a	4.41 a	5.97 a	8.85 a	2.19 a	3.32 a	5.54 a	7.40 a	10.79 a	3.73 a	6.05 a	8.44 a	12.53 a
	9	12	1.91 a	2.72 a	4.36 a	5.85 a	8.55 a	2.28 a	3.37 a	5.43 a	7.19 a	10.35 a	3.80 a	6.04 a	8.29 a	12.00 a
		16	1.82 a	2.63 a	4.27 a	5.76 a	8.45 a	2.19 a	3.27 a	5.33 a	7.09 a	10.25 a	3.69 a	5.94 a	8.18 a	11.89 a
		24	1.64 a	2.45 a	4.10 a	5.58 a	8.26 a	2.00 a	3.08 a	5.14 a	6.90 a	10.05 a	3.49 a	5.75 a	7.98 a	11.69 a
	10	12	1.77 a	2.56 a	4.07 a	5.47 a	7.95 a	2.13 a	3.16 a	5.04 a	6.69 a	9.60 a	3.60 a	5.71 a	7.79 a	11.15 a
		16	1.66 a	2.44 a	3.96 a	5.36 a	7.82 a	2.01 a	3.04 a	4.92 a	6.57 a	9.48 a	3.48 a	5.59 a	7.66 a	11.02 a
		24	1.45 a	2.23 a	3.75 a	5.14 a	7.58 a	1.79 a	2.81 a	4.69 a	6.34 a	9.23 a	3.23 a	5.35 a	7.40 a	10.78 a
	12	12	1.46 a	2.17 a	3.40 a	4.54 a	6.57 a	1.79 a	2.69 a	4.19 a	5.56 a	7.96 a	3.15 a	4.93 a	6.51 a	9.32 a
		16	1.32 a	2.02 a	3.25 a	4.39 a	6.41 a	1.63 a	2.53 a	4.03 a	5.40 a	7.79 a	2.97 a	4.76 a	6.34 a	9.15 a
		24	1.05 b	1.74 a	2.99 a	4.11 a	6.10 a	1.35 a	2.22 a	3.74 a	5.09 a	7.47 a	2.64 a	4.44 a	6.00 a	8.82 a
	14	12	1.13 a	1.75 a	2.70 a	3.57 a	5.17 a	1.43 a	2.19 a	3.32 a	4.38 a	6.30 a	2.59 a	3.93 a	5.17 a	7.46 a
		16	0.97 c	1.57 a	2.54 a	3.40 a	4.98 a	1.25 b	1.99 a	3.14 a	4.20 a	6.11 a	2.38 a	3.74 a	4.97 a	7.26 a
		24	0.69 d	1.26 c	2.25 b	3.10 a	4.65 a	0.92 d	1.65 b	2.82 a	3.86 a	5.75 a	2.00 b	3.38 a	4.60 a	6.89 a
	16	12	0.84 c	1.35 b	2.11 a	2.78 a	4.03 a	1.07 b	1.71 a	2.60 a	3.42 a	4.94 a	2.05 a	3.09 a	4.05 a	5.91 a
		16	0.67 d	1.17 c	1.94 b	2.61 a	3.84 a	0.89 d	1.51 b	2.41 a	3.23 a	4.75 a	1.82 b	2.88 a	3.85 a	5.70 a
		24	0.38 e	0.85 e	1.65 d	2.30 c	3.51 b	0.56 e	1.15 d	2.09 c	2.89 b	4.39 a	1.43 d	2.52 c	3.47 b	5.32 a

See page 27 for clarification of code developed wind pressures prior to using this table.

Notes:

- 1 For additional general notes, see page 41.
- 2 Allowable axial loads listed in kips (1 kip = 1000 pounds).
- 3 Allowable axial loads determined in accordance with AISI S100-16 (2020) w/ S2-20 and assuming that all axial loads pass through centroid of effective section.
- 4 Listed tables are based on simple (single)-span.
- 5 Studs are assumed to be adequately braced at a maximum spacing of L_u to develop full allowable moment, M_a .
- 6 Cells marked with an "a," "b," "c," "d," "e," or "f" meet L/720, L/600, L/480, L/360, L/240, or L/120 respectively. Blank cells do not meet L/120.
- 7 For deflection calculations, lateral loads are multiplied by 0.7 per AISI S240 except for 5psf load which is considered interior wall load.
- 8 Cells marked with an "*" have $h/t > 200$, and thus require bearing stiffeners. Cells are left blank when $h/t > 260$.

Complies with AISI S100-16 (2020) w/S2-20 • IBC 2024

ALLOWABLE COMBINED AXIAL & LATERAL LOADS

(Kips/Stud)

Wind = 5psf		S162 (1-5/8" Flange)					S200 (2" Flange)					S250 (2-1/2" Flange)				
Stud length (ft)	Spacing (in) o.c.	-33	-43	-54	-68	-97	-33	-43	-54	-68	-97	-43	-54	-68	-97	
		(20ga) 33ksi	(18ga) 33ksi	(16ga) 50ksi	(14ga) 50ksi	(12ga) 50ksi	(20ga) 33ksi	(18ga) 33ksi	(16ga) 50ksi	(14ga) 50ksi	(12ga) 50ksi	(18ga) 33ksi	(16ga) 50ksi	(14ga) 50ksi	(12ga) 50ksi	
6" Stud	8	12	2.41 a	3.38 a	5.59 a	7.43 a	11.38 a	2.86 a	4.30 a	7.46 a	9.96 a	15.63 a	4.65 a	7.64 a	11.05 a	18.26 a
		16	2.36 a	3.33 a	5.55 a	7.39 a	11.33 a	2.81 a	4.25 a	7.40 a	9.90 a	15.57 a	4.59 a	7.59 a	10.99 a	18.20 a
		24	2.27 a	3.24 a	5.46 a	7.30 a	11.24 a	2.71 a	4.15 a	7.30 a	9.80 a	15.46 a	4.49 a	7.49 a	10.88 a	18.08 a
	9	12	2.37 a	3.34 a	5.55 a	7.39 a	11.34 a	2.79 a	4.22 a	7.31 a	9.77 a	15.36 a	4.56 a	7.50 a	10.84 a	17.89 a
		16	2.31 a	3.28 a	5.50 a	7.33 a	11.28 a	2.73 a	4.15 a	7.24 a	9.71 a	15.29 a	4.49 a	7.44 a	10.77 a	17.82 a
		24	2.18 a	3.16 a	5.38 a	7.22 a	11.16 a	2.61 a	4.02 a	7.10 a	9.57 a	15.15 a	4.36 a	7.31 a	10.63 a	17.66 a
	10	12	2.32 a	3.29 a	5.50 a	7.34 a	11.28 a	2.72 a	4.12 a	7.13 a	9.55 a	15.03 a	4.47 a	7.34 a	10.60 a	17.46 a
		16	2.24 a	3.21 a	5.43 a	7.27 a	11.21 a	2.64 a	4.04 a	7.04 a	9.46 a	14.94 a	4.38 a	7.26 a	10.51 a	17.36 a
		24	2.09 a	3.06 a	5.28 a	7.12 a	11.06 a	2.49 a	3.87 a	6.87 a	9.29 a	14.76 a	4.21 a	7.09 a	10.33 a	17.17 a
	12	12	2.15 a	3.12 a	5.31 a	7.21 a	11.14 a	2.54 a	3.86 a	6.66 a	8.96 a	14.15 a	4.23 a	6.93 a	9.99 a	16.36 a
		16	2.04 a	3.01 a	5.20 a	7.09 a	11.02 a	2.42 a	3.74 a	6.53 a	8.84 a	14.02 a	4.10 a	6.81 a	9.85 a	16.21 a
		24	1.82 a	2.79 a	4.98 a	6.87 a	10.78 a	2.20 a	3.50 a	6.29 a	8.58 a	13.75 a	3.86 a	6.57 a	9.59 a	15.92 a
14	12	1.94 a	2.87 a	4.88 a	6.71 a	10.87 a	2.31 a	3.54 a	6.06 a	8.20 a	13.00 a	3.92 a	6.44 a	9.24 a	15.00 a	
	16	1.79 a	2.72 a	4.73 a	6.55 a	10.68 a	2.15 a	3.38 a	5.89 a	8.03 a	12.81 a	3.75 a	6.27 a	9.06 a	14.79 a	
	24	1.51 a	2.43 a	4.44 a	6.24 a	10.32 a	1.86 a	3.06 a	5.56 a	7.68 a	12.43 a	3.43 a	5.95 a	8.69 a	14.38 a	
16	12	1.69 a	2.56 a	4.35 a	6.02 a	9.77 a	2.04 a	3.16 a	5.36 a	7.31 a	11.64 a	3.57 a	5.93 a	8.41 a	13.44 a	
	16	1.50 a	2.37 a	4.16 a	5.81 a	9.52 a	1.85 a	2.96 a	5.15 a	7.08 a	11.39 a	3.35 a	5.72 a	8.17 a	13.17 a	
	24	1.17 b	2.02 a	3.80 a	5.42 a	9.07 a	1.50 a	2.57 a	4.75 a	6.66 a	10.91 a	2.94 a	5.30 a	7.71 a	12.65 a	
8" Stud	8	12	2.39 a*	3.35 a	5.43 a	7.24 a	11.26 a	2.96 a*	4.47 a	7.74 a	10.28 a	15.97 a	4.89 a	8.17 a	11.80 a	19.76 a
		16	2.36 a*	3.32 a	5.40 a	7.21 a	11.23 a	2.93 a*	4.43 a	7.70 a	10.24 a	15.93 a	4.85 a	8.13 a	11.76 a	19.72 a
		24	2.29 a*	3.25 a	5.34 a	7.16 a	11.18 a	2.85 a*	4.36 a	7.63 a	10.17 a	15.86 a	4.77 a	8.06 a	11.68 a	19.63 a
	9	12	2.36 a*	3.32 a	5.40 a	7.22 a	11.24 a	2.93 a*	4.44 a	7.71 a	10.24 a	15.94 a	4.84 a	8.10 a	11.72 a	19.64 a
		16	2.32 a*	3.28 a	5.37 a	7.18 a	11.20 a	2.89 a*	4.39 a	7.66 a	10.20 a	15.89 a	4.79 a	8.05 a	11.67 a	19.58 a
		24	2.23 a*	3.20 a	5.29 a	7.11 a	11.13 a	2.79 a*	4.29 a	7.56 a	10.10 a	15.80 a	4.69 a	7.96 a	11.57 a	19.47 a
	10	12	2.33 a*	3.29 a	5.38 a	7.19 a	11.21 a	2.90 a*	4.40 a	7.67 a	10.21 a	15.90 a	4.79 a	8.02 a	11.63 a	19.49 a
		16	2.28 a*	3.24 a	5.33 a	7.14 a	11.16 a	2.84 a*	4.34 a	7.61 a	10.15 a	15.84 a	4.73 a	7.96 a	11.56 a	19.42 a
		24	2.17 a*	3.14 a	5.23 a	7.05 a	11.07 a	2.73 a*	4.22 a	7.49 a	10.03 a	15.72 a	4.60 a	7.84 a	11.43 a	19.28 a
	12	12	2.25 a*	3.22 a	5.30 a	7.12 a	11.14 a	2.81 a*	4.31 a	7.58 a	10.11 a	15.81 a	4.65 a	7.80 a	11.38 a	19.09 a
		16	2.17 a*	3.14 a	5.23 a	7.05 a	11.07 a	2.73 a*	4.22 a	7.49 a	10.02 a	15.72 a	4.56 a	7.72 a	11.28 a	18.98 a
		24	2.02 a*	2.99 a	5.09 a	6.91 a	10.93 a	2.56 a*	4.04 a	7.31 a	9.85 a	15.54 a	4.38 a	7.54 a	11.09 a	18.78 a
	14	12	2.16 a*	3.12 a	5.21 a	7.03 a	11.04 a	2.68 a*	4.15 a	7.35 a	9.92 a	15.68 a	4.47 a	7.51 a	10.97 a	18.42 a
		16	2.05 a*	3.02 a	5.11 a	6.93 a	10.94 a	2.56 a*	4.02 a	7.22 a	9.79 a	15.55 a	4.34 a	7.39 a	10.84 a	18.28 a
		24	1.83 a*	2.81 a	4.91 a	6.73 a	10.75 a	2.34 a*	3.78 a	6.97 a	9.54 a	15.28 a	4.10 a	7.15 a	10.57 a	17.98 a
	16	12	2.04 a*	3.01 a	5.10 a	6.91 a	10.92 a	2.51 a*	3.91 a	6.93 a	9.41 a	15.08 a	4.24 a	7.13 a	10.41 a	17.43 a
		16	1.90 a*	2.87 a	4.96 a	6.78 a	10.78 a	2.36 a*	3.75 a	6.76 a	9.23 a	14.90 a	4.08 a	6.97 a	10.23 a	17.23 a
		24	1.62 a*	2.59 a	4.69 a	6.51 a	10.51 a	2.07 a*	3.44 a	6.43 a	8.90 a	14.55 a	3.76 a	6.66 a	9.88 a	16.85 a

See page 27 for clarification of code developed wind pressures prior to using this table.

Notes:

- 1 For additional general notes, see page 41.
- 2 Allowable axial loads listed in kips (1 kip = 1000 pounds).
- 3 Allowable axial loads determined in accordance with AISI S100-16 (2020) w/ S2-20 and assuming that all axial loads pass through centroid of effective section.
- 4 Listed tables are based on simple (single)-span.
- 5 Studs are assumed to be adequately braced at a maximum spacing of Lu to develop full allowable moment, Ma.
- 6 Cells marked with an "a," "b," "c," "d," "e," or "F" meet L/720, L/600, L/480, L/360, L/240, or L/120 respectively. Blank cells do not meet L/120.
- 7 For deflection calculations, lateral loads are multiplied by 0.7 per AISI S240 except for 5psf load which is considered interior wall load.
- 8 Cells marked with an "*" have h/t > 200, and thus require bearing stiffeners. Cells are left blank when h/t > 260.

Complies with AISI S100-16 (2020) w/S2-20 • IBC 2024

The technical content of this literature is effective 06/01/24 and supersedes all previous information.

ALLOWABLE COMBINED AXIAL & LATERAL LOADS (Kips/Stud)

Wind = 15psf		S162 (1-5/8" Flange)					S200 (2" Flange)					S250 (2-1/2" Flange)				
Stud length (ft)	Spacing (in) o.c.	-33	-43	-54	-68	-97	-33	-43	-54	-68	-97	-43	-54	-68	-97	
		(20ga) 33ksi	(18ga) 33ksi	(16ga) 50ksi	(14ga) 50ksi	(12ga) 50ksi	(20ga) 33ksi	(18ga) 33ksi	(16ga) 50ksi	(14ga) 50ksi	(12ga) 50ksi	(18ga) 33ksi	(16ga) 50ksi	(14ga) 50ksi	(12ga) 50ksi	
3-5/8" Stud	8	12	1.43 a	2.20 a	3.73 a	4.96 a	7.39 a	1.77 a	2.79 a	4.71 a	6.22 a	9.06 a	3.19 a	5.32 a	7.25 a	10.56 a
		16	1.22 a	1.98 a	3.53 a	4.75 a	7.17 a	1.55 a	2.56 a	4.49 a	5.99 a	8.83 a	2.95 a	5.08 a	7.01 a	10.34 a
		24	0.84 a	1.58 a	3.14 a	4.36 a	6.73 a	1.13 a	2.13 a	4.06 a	5.57 a	8.38 a	2.48 a	4.62 a	6.53 a	9.89 a
	9	12	1.19 a	1.92 a	3.33 a	4.46 a	6.69 a	1.51 a	2.47 a	4.21 a	5.59 a	8.21 a	2.87 a	4.84 a	6.54 a	9.62 a
		16	0.95 a	1.67 a	3.09 a	4.21 a	6.41 a	1.25 a	2.19 a	3.94 a	5.32 a	7.92 a	2.57 a	4.54 a	6.24 a	9.34 a
		24	0.51 c	1.20 a	2.64 a	3.75 a	5.89 a	0.76 b	1.68 a	3.44 a	4.82 a	7.38 a	2.01 a	4 a	5.68 a	8.8 a
	10	12	0.96 a	1.64 a	2.91 a	3.92 a	5.93 a	1.25 a	2.13 a	3.69 a	4.94 a	7.3 a	2.51 a	4.33 a	5.79 a	8.63 a
		16	0.69 b	1.35 a	2.64 a	3.65 a	5.61 a	0.95 a	1.82 a	3.38 a	4.63 a	6.98 a	2.17 a	3.99 a	5.45 a	8.3 a
		24	0.21 d	0.84 c	2.15 b	3.13 a	5.03 a	0.42 c	1.25 b	2.83 a	4.07 a	6.37 a	1.54 a	3.37 a	4.82 a	7.68 a
	12	12	0.52 d	1.08 b	2.07 a	2.87 a	4.40 a	0.74 c	1.46 a	2.66 a	3.64 a	5.5 a	1.77 a	3.17 a	4.32 a	6.62 a
		16	0.22 e	0.76 d	1.78 c	2.56 b	4.05 a	0.41 d	1.11 c	2.32 b	3.3 a	5.13 a	1.37 b	2.79 a	3.93 a	6.24 a
		24	—	0.20 e	1.25 d	2.01 d	3.42 b	—	0.49 d	1.73 d	2.7 c	4.46 a	0.67 d	2.12 c	3.25 b	5.54 a
14	12	0.17 e	0.61 d	1.40 d	2.02 c	3.17 a	0.32 e	0.9 d	1.82 c	2.6 b	4.03 a	1.12 c	2.19 b	3.11 a	4.94 a	
	16	—	0.28 e	1.11 e	1.71 d	2.82 c	—	0.54 e	1.49 d	2.26 c	3.65 b	0.71 d	1.82 c	2.72 b	4.54 a	
	24	—	—	0.60 f	1.17 e	2.21 d	—	0.92 e	1.67 e	3 d	0.01 e	1.17 e	2.05 d	3.84 c		
16	12	—	0.25 e	0.91 e	1.39 d	2.27 c	0.01 f	0.46 e	1.22 d	1.84 d	2.95 b	0.61 e	1.49 d	2.22 c	3.68 a	
	16	—	—	0.63 f	1.10 e	1.94 d	—	0.12 f	0.91 e	1.51 e	2.59 d	0.22 e	1.13 e	1.85 d	3.29 c	
	24	—	—	0.16 f	0.60 f	1.36 e	—	—	0.38 f	0.96 f	1.96 e	—	0.53 f	1.21 e	2.62 d	
4" Stud	8	12	1.61 a	2.45 a	4.21 a	5.77 a	8.63 a	1.97 a	3.10 a	5.32 a	7.18 a	10.56 a	3.49 a	5.83 a	8.20 a	12.30 a
		16	1.41 a	2.24 a	4.02 a	5.56 a	8.40 a	1.76 a	2.88 a	5.10 a	6.96 a	10.33 a	3.27 a	5.61 a	7.97 a	12.07 a
		24	1.04 a	1.86 a	3.64 a	5.17 a	7.97 a	1.35 a	2.46 a	4.68 a	6.53 a	9.89 a	2.83 a	5.19 a	7.52 a	11.62 a
	9	12	1.39 a	2.20 a	3.85 a	5.32 a	7.97 a	1.73 a	2.80 a	4.86 a	6.61 a	9.76 a	3.20 a	5.46 a	7.68 a	11.40 a
		16	1.15 a	1.95 a	3.61 a	5.07 a	7.70 a	1.47 a	2.53 a	4.59 a	6.34 a	9.47 a	2.92 a	5.19 a	7.38 a	11.11 a
		24	0.71 b	1.49 a	3.16 a	4.59 a	7.17 a	0.99 a	2.03 a	4.09 a	5.82 a	8.92 a	2.39 a	4.67 a	6.82 a	10.56 a
	10	12	1.16 a	1.93 a	3.46 a	4.82 a	7.24 a	1.47 a	2.47 a	4.36 a	6.00 a	8.88 a	2.88 a	5.00 a	7.04 a	10.42 a
		16	0.89 a	1.64 a	3.18 a	4.53 a	6.91 a	1.18 a	2.16 a	4.05 a	5.67 a	8.54 a	2.55 a	4.68 a	6.69 a	10.08 a
		24	0.40 c	1.12 b	2.66 a	3.98 a	6.30 a	0.64 b	1.59 a	3.47 a	5.07 a	7.90 a	1.93 a	4.07 a	6.03 a	9.42 a
	12	12	0.71 b	1.36 a	2.63 a	3.72 a	5.67 a	0.96 b	1.81 a	3.33 a	4.67 a	7.02 a	2.19 a	3.99 a	5.54 a	8.36 a
		16	0.39 d	1.03 c	2.30 b	3.37 a	5.28 a	0.61 c	1.44 b	2.96 a	4.28 a	6.61 a	1.78 a	3.58 a	5.11 a	7.93 a
		24	—	0.43 d	1.71 d	2.74 c	4.56 a	—	0.78 d	2.31 c	3.59 b	5.85 a	1.05 c	2.86 b	4.34 a	7.14 a
	14	12	0.31 d	0.85 c	1.86 c	2.70 a	4.19 a	0.50 d	1.20 c	2.39 b	3.42 a	5.27 a	1.50 b	2.90 a	4.11 a	6.38 a
		16	—	0.50 d	1.53 d	2.34 c	3.79 a	0.14 e	0.81 d	2.02 c	3.03 b	4.84 a	1.06 c	2.48 b	3.67 a	5.93 a
		24	—	—	0.94 e	1.71 d	3.08 c	—	0.13 e	1.36 e	2.33 d	4.08 c	0.30 e	1.75 d	2.89 c	5.11 b
	16	12	0.01 e	0.44 e	1.27 d	1.91 c	3.06 b	0.14 e	0.70 d	1.67 d	2.46 c	3.91 a	0.92 d	2.05 c	2.99 b	4.81 a
		16	—	0.09 e	0.94 e	1.56 d	2.67 c	—	0.32 e	1.30 e	2.08 d	3.49 c	0.48 e	1.64 d	2.56 c	4.36 b
		24	—	—	0.38 f	0.97 e	2.00 e	—	—	0.68 f	1.43 e	2.77 d	—	0.94 e	1.82 e	3.57 d

See page 27 for clarification of code developed wind pressures prior to using this table.

Notes:

- 1 For additional general notes, see page 41.
- 2 Allowable axial loads listed in kips (1 kip = 1000 pounds).
- 3 Allowable axial loads determined in accordance with AISI S100-16 (2020) w/ S2-20 and assuming that all axial loads pass through centroid of effective section.
- 4 Listed tables are based on simple (single)-span.
- 5 Studs are assumed to be adequately braced at a maximum spacing of Lu to develop full allowable moment, Ma.
- 6 Cells marked with an "a," "b," "c," "d," "e," or "f" meet L/720, L/600, L/480, L/360, L/240, or L/120 respectively. Blank cells do not meet L/120.
- 7 For deflection calculations, lateral loads are multiplied by 0.7 per AISI S240 except for 5psf load which is considered interior wall load.
- 8 Cells marked with an "*" have h/t > 200, and thus require bearing stiffeners. Cells are left blank when h/t > 260.

Complies with AISI S100-16 (2020) w/S2-20 • IBC 2024

ALLOWABLE COMBINED AXIAL & LATERAL LOADS (Kips/Stud)

Wind = 15psf		S162 (1-5/8" Flange)					S200 (2" Flange)					S250 (2-1/2" Flange)				
Stud length (ft)	Spacing (in) o.c.	-33	-43	-54	-68	-97	-33	-43	-54	-68	-97	-43	-54	-68	-97	
		(20ga) 33ksi	(18ga) 33ksi	(16ga) 50ksi	(14ga) 50ksi	(12ga) 50ksi	(20ga) 33ksi	(18ga) 33ksi	(16ga) 50ksi	(14ga) 50ksi	(12ga) 50ksi	(18ga) 33ksi	(16ga) 50ksi	(14ga) 50ksi	(12ga) 50ksi	
6" Stud	8	12	2.12 a	3.10 a	5.33 a	7.17 a	11.11 a	2.56 a	3.99 a	7.14 a	9.64 a	15.30 a	4.33 a	7.34 a	10.72 a	17.90 a
		16	1.98 a	2.96 a	5.20 a	7.04 a	10.98 a	2.42 a	3.84 a	6.99 a	9.49 a	15.14 a	4.17 a	7.19 a	10.56 a	17.73 a
		24	1.70 a	2.69 a	4.94 a	6.78 a	10.71 a	2.13 a	3.53 a	6.68 a	9.18 a	14.82 a	3.86 a	6.89 a	10.24 a	17.38 a
	9	12	2.00 a	2.98 a	5.21 a	7.05 a	10.99 a	2.42 a	3.82 a	6.90 a	9.37 a	14.94 a	4.16 a	7.11 a	10.42 a	17.44 a
		16	1.82 a	2.80 a	5.04 a	6.88 a	10.81 a	2.23 a	3.63 a	6.70 a	9.17 a	14.73 a	3.96 a	6.92 a	10.21 a	17.21 a
		24	1.47 a	2.46 a	4.71 a	6.55 a	10.47 a	1.87 a	3.24 a	6.31 a	8.77 a	14.31 a	3.56 a	6.54 a	9.80 a	16.76 a
	10	12	1.86 a	2.84 a	5.07 a	6.90 a	10.83 a	2.26 a	3.62 a	6.62 a	9.04 a	14.49 a	3.96 a	6.85 a	10.07 a	16.88 a
		16	1.64 a	2.62 a	4.85 a	6.69 a	10.61 a	2.03 a	3.38 a	6.37 a	8.79 a	14.23 a	3.72 a	6.62 a	9.80 a	16.59 a
		24	1.22 a	2.20 a	4.44 a	6.27 a	10.17 a	1.59 a	2.91 a	5.89 a	8.30 a	13.71 a	3.23 a	6.15 a	9.29 a	16.03 a
	12	12	1.51 a	2.47 a	4.66 a	6.54 a	10.43 a	1.88 a	3.16 a	5.93 a	8.21 a	13.35 a	3.50 a	6.22 a	9.20 a	15.49 a
		16	1.21 a	2.16 a	4.35 a	6.21 a	10.08 a	1.57 a	2.82 a	5.58 a	7.86 a	12.96 a	3.15 a	5.88 a	8.83 a	15.07 a
		24	0.64 a	1.58 a	3.75 a	5.60 a	9.42 a	0.98 a	2.19 a	4.91 a	7.17 a	12.21 a	2.49 a	5.23 a	8.10 a	14.26 a
14	12	1.11 a	2.02 a	4.02 a	5.79 a	9.80 a	1.45 a	2.61 a	5.09 a	7.20 a	11.89 a	2.96 a	5.49 a	8.18 a	13.80 a	
	16	0.74 a	1.63 a	3.62 a	5.37 a	9.31 a	1.07 a	2.19 a	4.65 a	6.73 a	11.37 a	2.52 a	5.04 a	7.68 a	13.24 a	
	24	0.07 c	0.92 b	2.89 a	4.58 a	8.40 a	0.36 c	1.42 a	3.84 a	5.87 a	10.40 a	1.70 a	4.22 a	6.76 a	12.19 a	
16	12	0.71 b	1.53 a	3.30 a	4.89 a	8.43 a	1.01 a	2.05 a	4.20 a	6.08 a	10.24 a	2.38 a	4.73 a	7.07 a	11.93 a	
	16	0.29 c	1.09 b	2.85 a	4.40 a	7.85 a	0.58 c	1.56 a	3.70 a	5.54 a	9.62 a	1.86 a	4.19 a	6.48 a	11.26 a	
	24	—	0.29 d	2.03 c	3.50 b	6.79 a	—	0.69 c	2.79 b	4.56 a	8.50 a	0.92 c	3.23 b	5.40 a	10.03 a	
8" Stud	8	12	2.19 a*	3.16 a	5.25 a	7.07 a	11.09 a	2.75 a*	4.24 a	7.52 a	10.06 a	15.75 a	4.66 a	7.95 a	11.56 a	19.51 a
		16	2.09 a*	3.06 a	5.16 a	6.99 a	11.01 a	2.64 a*	4.13 a	7.41 a	9.95 a	15.65 a	4.54 a	7.83 a	11.44 a	19.38 a
		24	1.89 a*	2.87 a	4.99 a	6.81 a	10.84 a	2.42 a*	3.91 a	7.19 a	9.73 a	15.43 a	4.31 a	7.61 a	11.21 a	19.13 a
	9	12	2.10 a*	3.07 a	5.18 a	7.00 a	11.02 a	2.66 a*	4.15 a	7.42 a	9.96 a	15.66 a	4.55 a	7.82 a	11.42 a	19.31 a
		16	1.98 a*	2.95 a	5.06 a	6.89 a	10.91 a	2.52 a*	4.01 a	7.28 a	9.82 a	15.52 a	4.40 a	7.67 a	11.26 a	19.15 a
		24	1.72 a*	2.71 a	4.84 a	6.67 a	10.69 a	2.25 a*	3.72 a	7.00 a	9.55 a	15.25 a	4.10 a	7.39 a	10.96 a	18.83 a
	10	12	2.01 a*	2.98 a	5.09 a	6.91 a	10.93 a	2.55 a*	4.04 a	7.31 a	9.85 a	15.55 a	4.42 a	7.66 a	11.24 a	19.08 a
		16	1.85 a*	2.83 a	4.95 a	6.77 a	10.80 a	2.38 a*	3.86 a	7.13 a	9.68 a	15.37 a	4.23 a	7.49 a	11.05 a	18.87 a
		24	1.54 a*	2.53 a	4.67 a	6.5 a	10.53 a	2.05 a*	3.51 a	6.78 a	9.33 a	15.03 a	3.87 a	7.13 a	10.68 a	18.47 a
	12	12	1.79 a*	2.76 a	4.88 a	6.71 a	10.72 a	2.31 a*	3.78 a	7.04 a	9.58 a	15.27 a	4.11 a	7.28 a	10.81 a	18.47 a
		16	1.56 a*	2.54 a	4.67 a	6.50 a	10.52 a	2.07 a*	3.52 a	6.77 a	9.32 a	15.01 a	3.85 a	7.02 a	10.53 a	18.17 a
		24	1.12 a*	2.11 a	4.26 a	6.10 a	10.11 a	1.59 a*	3.01 a	6.25 a	8.80 a	14.48 a	3.33 a	6.52 a	9.98 a	17.57 a
	14	12	1.52 a*	2.50 a	4.62 a	6.44 a	10.45 a	2.00 a*	3.42 a	6.60 a	9.17 a	14.90 a	3.73 a	6.79 a	10.18 a	17.55 a
		16	1.22 a*	2.20 a	4.33 a	6.16 a	10.16 a	1.68 a*	3.07 a	6.23 a	8.80 a	14.52 a	3.38 a	6.44 a	9.80 a	17.13 a
		24	0.64 a*	1.62 a	3.77 a	5.60 a	9.59 a	1.06 a*	2.40 a	5.53 a	8.08 a	13.77 a	2.69 a	5.76 a	9.05 a	16.30 a
	16	12	1.22 a*	2.19 a	4.30 a	6.11 a	10.1 a	1.64 a*	2.98 a	5.95 a	8.41 a	14.03 a	3.29 a	6.20 a	9.37 a	16.28 a
		16	0.84 a*	1.81 a	3.93 a	5.73 a	9.71 a	1.24 a*	2.55 a	5.50 a	7.94 a	13.52 a	2.85 a	5.75 a	8.88 a	15.73 a
		24	0.12 b*	1.08 a	3.21 a	5.00 a	8.95 a	0.49 a*	1.72 a	4.62 a	7.04 a	12.55 a	1.99 a	4.90 a	7.94 a	14.66 a

See page 27 for clarification of code developed wind pressures prior to using this table.

Notes:

- 1 For additional general notes, see page 41.
- 2 Allowable axial loads listed in kips (1 kip = 1000 pounds).
- 3 Allowable axial loads determined in accordance with AISI S100-16 (2020) w/ S2-20 and assuming that all axial loads pass through centroid of effective section.
- 4 Listed tables are based on simple (single)-span.
- 5 Studs are assumed to be adequately braced at a maximum spacing of Lu to develop full allowable moment, Ma.
- 6 Cells marked with an "a," "b," "c," "d," "e," or "F" meet L/720, L/600, L/480, L/360, L/240, or L/120 respectively. Blank cells do not meet L/120.
- 7 For deflection calculations, lateral loads are multiplied by 0.7 per AISI S240 except for 5psf load which is considered interior wall load.
- 8 Cells marked with an "*" have h/t > 200, and thus require bearing stiffeners. Cells are left blank when h/t > 260.

Complies with AISI S100-16 (2020) w/S2-20 • IBC 2024

The technical content of this literature is effective 06/01/24 and supersedes all previous information.

ALLOWABLE COMBINED AXIAL & LATERAL LOADS (Kips/Stud)

Wind = 20psf		S162 (1-5/8" Flange)					S200 (2" Flange)					S250 (2-1/2" Flange)				
Stud length (ft)	Spacing (in) o.c.	-33	-43	-54	-68	-97	-33	-43	-54	-68	-97	-43	-54	-68	-97	
		(20ga) 33ksi	(18ga) 33ksi	(16ga) 50ksi	(14ga) 50ksi	(12ga) 50ksi	(20ga) 33ksi	(18ga) 33ksi	(16ga) 50ksi	(14ga) 50ksi	(12ga) 50ksi	(18ga) 33ksi	(16ga) 50ksi	(14ga) 50ksi	(12ga) 50ksi	
3-5/8" Stud	8	12	1.22 a	1.98 a	3.53 a	4.75 a	7.17 a	1.55 a	2.56 a	4.49 a	5.99 a	8.83 a	2.95 a	5.08 a	7.01 a	10.34 a
		16	0.96 a	1.71 a	3.27 a	4.49 a	6.88 a	1.27 a	2.27 a	4.20 a	5.71 a	8.52 a	2.63 a	4.77 a	6.69 a	10.04 a
		24	0.48 b	1.21 a	2.78 a	3.99 a	6.32 a	0.74 b	1.71 a	3.65 a	5.16 a	7.95 a	2.03 a	4.19 a	6.08 a	9.46 a
	9	12	0.95 a	1.67 a	3.09 a	4.21 a	6.41 a	1.25 a	2.19 a	3.94 a	5.32 a	7.92 a	2.57 a	4.54 a	6.24 a	9.34 a
		16	0.65 b	1.36 a	2.79 a	3.90 a	6.06 a	0.92 a	1.85 a	3.60 a	4.98 a	7.56 a	2.19 a	4.18 a	5.86 a	8.98 a
		24	0.11 d	0.78 c	2.23 b	3.32 a	5.41 a	0.32 c	1.21 b	2.97 a	4.35 a	6.88 a	1.49 a	3.49 a	5.15 a	8.29 a
	10	12	0.69 b	1.35 a	2.64 a	3.65 a	5.61 a	0.95 a	1.82 a	3.38 a	4.63 a	6.98 a	2.17 a	3.99 a	5.45 a	8.30 a
		16	0.36 d	1.00 c	2.31 a	3.30 a	5.22 a	0.59 c	1.43 b	3.00 a	4.25 a	6.57 a	1.74 a	3.57 a	5.02 a	7.88 a
		24	—	0.37 d	1.70 c	2.66 b	4.49 a	—	0.74 d	2.32 c	3.55 b	5.80 a	0.97 c	2.81 b	4.24 a	7.10 a
	12	12	0.22 e	0.76 d	1.78 c	2.56 b	4.05 a	0.41 d	1.11 c	2.32 b	3.30 a	5.13 a	1.37 b	2.79 a	3.93 a	6.24 a
		16	—	0.37 e	1.42 d	2.18 c	3.62 b	0.01 e	0.69 d	1.92 c	2.89 b	4.68 a	0.90 d	2.33 c	3.47 a	5.76 a
		24	—	—	0.79 e	1.52 e	2.86 d	—	—	1.21 e	2.16 d	3.86 c	0.06 e	1.53 d	2.64 c	4.91 b
14	12	—	0.28 e	1.11 e	1.71 d	2.82 c	—	0.54 e	1.49 d	2.26 c	3.65 b	0.71 d	1.82 c	2.72 b	4.54 a	
	16	—	—	0.76 e	1.34 e	2.40 d	—	0.12 e	1.10 e	1.86 d	3.20 c	0.23 e	1.38 d	2.26 d	4.06 b	
	24	—	—	0.16 f	1.01 f	1.67 e	—	—	0.43 f	1.16 e	2.42 e	—	0.61 e	1.46 e	3.22 d	
16	12	—	—	0.63 f	1.10 e	1.94 d	—	0.12 f	0.91 e	1.51 e	2.59 d	0.22 e	1.13 e	1.85 d	3.29 c	
	16	—	—	0.31 f	0.75 f	1.54 e	—	—	0.54 f	1.13 e	2.16 e	—	0.72 e	1.41 e	2.83 d	
	24	—	—	—	0.16 f	0.87 f	—	—	—	0.48 f	1.42 f	—	—	0.66 f	2.04 e	
4" Stud	8	12	1.41 a	2.24 a	4.02 a	5.56 a	8.40 a	1.76 a	2.88 a	5.10 a	6.96 a	10.33 a	3.27 a	5.61 a	7.97 a	12.07 a
		16	1.16 a	1.99 a	3.76 a	5.30 a	8.12 a	1.48 a	2.59 a	4.82 a	6.67 a	10.03 a	2.97 a	5.33 a	7.67 a	11.77 a
		24	0.68 a	1.49 a	3.28 a	4.80 a	7.56 a	0.97 a	2.05 a	4.28 a	6.12 a	9.45 a	2.41 a	4.79 a	7.09 a	11.19 a
	9	12	1.15 a	1.95 a	3.61 a	5.07 a	7.70 a	1.47 a	2.53 a	4.59 a	6.34 a	9.47 a	2.92 a	5.19 a	7.38 a	11.11 a
		16	0.86 a	1.64 a	3.31 a	4.75 a	7.34 a	1.15 a	2.19 a	4.25 a	5.99 a	9.10 a	2.56 a	4.84 a	7.01 a	10.74 a
		24	0.31 c	1.06 b	2.74 a	4.14 a	6.67 a	0.55 b	1.55 a	3.61 a	5.33 a	8.40 a	1.89 a	4.18 a	6.29 a	10.02 a
	10	12	0.89 a	1.64 a	3.18 a	4.53 a	6.91 a	1.18 a	2.16 a	4.05 a	5.67 a	8.54 a	2.55 a	4.68 a	6.69 a	10.08 a
		16	0.55 c	1.29 a	2.83 a	4.16 a	6.50 a	0.81 b	1.77 a	3.66 a	5.27 a	8.10 a	2.13 a	4.27 a	6.24 a	9.64 a
		24	—	0.64 c	2.19 b	3.47 a	5.73 a	0.15 d	1.07 c	2.94 a	4.51 a	7.30 a	1.36 b	3.50 a	5.42 a	8.81 a
	12	12	0.39 d	1.03 c	2.30 b	3.37 a	5.28 a	0.61 c	1.44 b	2.96 a	4.28 a	6.61 a	1.78 a	3.58 a	5.11 a	7.93 a
		16	0.02 e	0.62 d	1.90 c	2.94 b	4.79 a	0.20 d	0.99 c	2.52 b	3.81 a	6.09 a	1.28 c	3.09 a	4.59 a	7.39 a
		24	—	—	1.20 e	2.18 d	3.93 c	—	0.20 e	1.73 d	2.97 c	5.17 b	0.40 d	2.21 c	3.66 b	6.43 a
	14	12	—	0.50 d	1.53 d	2.34 c	3.79 a	0.14 e	0.81 d	2.02 c	3.03 b	4.84 a	1.06 c	2.48 b	3.67 a	5.93 a
		16	—	0.07 e	1.12 e	1.91 d	3.30 c	—	0.34 e	1.57 d	2.55 c	4.32 b	0.54 d	1.98 d	3.14 c	5.37 a
		24	—	—	0.43 f	1.17 e	2.46 d	—	—	0.79 e	1.73 e	3.41 d	—	1.11 e	2.22 d	4.39 c
	16	12	—	0.09 e	0.94 e	1.56 d	2.67 c	—	0.32 e	1.30 e	2.08 d	3.49 c	0.48 e	1.64 d	2.56 c	4.36 b
		16	—	—	0.56 f	1.16 e	2.21 d	—	—	0.87 e	1.63 e	3.00 d	—	1.16 e	2.05 d	3.82 c
		24	—	—	—	0.46 f	1.42 e	—	—	0.14 f	0.86 f	2.13 e	—	0.34 f	1.19 e	2.89 e

See page 27 for clarification of code developed wind pressures prior to using this table.

Notes:

- 1 For additional general notes, see page 41.
- 2 Allowable axial loads listed in kips (1 kip = 1000 pounds).
- 3 Allowable axial loads determined in accordance with AISI S100-16 (2020) w/ S2-20 and assuming that all axial loads pass through centroid of effective section.
- 4 Listed tables are based on simple (single)-span.
- 5 Studs are assumed to be adequately braced at a maximum spacing of L_u to develop full allowable moment, M_a .
- 6 Cells marked with an "a," "b," "c," "d," "e," or "f" meet L/720, L/600, L/480, L/360, L/240, or L/120 respectively. Blank cells do not meet L/120.
- 7 For deflection calculations, lateral loads are multiplied by 0.7 per AISI S240 except for 5psf load which is considered interior wall load.
- 8 Cells marked with an "*" have $h/t > 200$, and thus require bearing stiffeners. Cells are left blank when $h/t > 260$.

Complies with AISI S100-16 (2020) w/S2-20 • IBC 2024

ALLOWABLE COMBINED AXIAL & LATERAL LOADS (Kips/Stud)

Wind = 20psf		S162 (1-5/8" Flange)					S200 (2" Flange)					S250 (2-1/2" Flange)				
Stud length (ft)	Spacing (in) o.c.	-33	-43	-54	-68	-97	-33	-43	-54	-68	-97	-43	-54	-68	-97	
		(20ga) 33ksi	(18ga) 33ksi	(16ga) 50ksi	(14ga) 50ksi	(12ga) 50ksi	(20ga) 33ksi	(18ga) 33ksi	(16ga) 50ksi	(14ga) 50ksi	(12ga) 50ksi	(18ga) 33ksi	(16ga) 50ksi	(14ga) 50ksi	(12ga) 50ksi	
6" Stud	8	12	1.98 a	2.96 a	5.20 a	7.04 a	10.98 a	2.42 a	3.84 a	6.99 a	9.49 a	15.14 a	4.17 a	7.19 a	10.56 a	17.73 a
		16	1.80 a	2.78 a	5.02 a	6.87 a	10.80 a	2.22 a	3.63 a	6.78 a	9.28 a	14.93 a	3.96 a	6.99 a	10.34 a	17.50 a
		24	1.43 a	2.42 a	4.68 a	6.52 a	10.45 a	1.84 a	3.23 a	6.37 a	8.87 a	14.50 a	3.55 a	6.59 a	9.92 a	17.03 a
	9	12	1.82 a	2.80 a	5.04 a	6.88 a	10.81 a	2.23 a	3.63 a	6.70 a	9.17 a	14.73 a	3.96 a	6.92 a	10.21 a	17.21 a
		16	1.59 a	2.57 a	4.82 a	6.66 a	10.58 a	1.99 a	3.37 a	6.44 a	8.90 a	14.45 a	3.69 a	6.67 a	9.93 a	16.91 a
		24	1.13 a	2.12 a	4.38 a	6.22 a	10.13 a	1.52 a	2.86 a	5.93 a	8.38 a	13.91 a	3.18 a	6.17 a	9.39 a	16.31 a
	10	12	1.64 a	2.62 a	4.85 a	6.69 a	10.61 a	2.03 a	3.38 a	6.37 a	8.79 a	14.23 a	3.72 a	6.62 a	9.80 a	16.59 a
		16	1.36 a	2.34 a	4.57 a	6.41 a	10.32 a	1.74 a	3.07 a	6.05 a	8.46 a	13.88 a	3.39 a	6.30 a	9.46 a	16.22 a
		24	0.81 a	1.79 a	4.03 a	5.86 a	9.74 a	1.17 a	2.46 a	5.42 a	7.82 a	13.20 a	2.77 a	5.69 a	8.79 a	15.48 a
	12	12	1.21 a	2.16 a	4.35 a	6.21 a	10.08 a	1.57 a	2.82 a	5.58 a	7.86 a	12.96 a	3.15 a	5.88 a	8.83 a	15.07 a
		16	0.83 a	1.77 a	3.95 a	5.80 a	9.64 a	1.17 a	2.39 a	5.13 a	7.39 a	12.45 a	2.71 a	5.44 a	8.34 a	14.53 a
		24	0.12 c	1.03 a	3.20 a	5.01 a	8.78 a	0.44 b	1.59 a	4.29 a	6.51 a	11.49 a	1.87 a	4.61 a	7.41 a	13.48 a
14	12	0.74 a	1.63 a	3.62 a	5.37 a	9.31 a	1.07 a	2.19 a	4.65 a	6.73 a	11.37 a	2.52 a	5.04 a	7.68 a	13.24 a	
	16	0.28 c	1.15 b	3.13 a	4.84 a	8.69 a	0.59 b	1.67 a	4.10 a	6.15 a	10.71 a	1.96 a	4.49 a	7.06 a	12.53 a	
	24	—	0.27 d	2.22 c	3.86 a	7.55 a	—	0.71 c	3.09 b	5.07 a	9.50 a	0.94 b	3.46 a	5.90 a	11.21 a	
16	12	0.29 c	1.09 b	2.85 a	4.40 a	7.85 a	0.58 c	1.56 a	3.70 a	5.54 a	9.62 a	1.86 a	4.19 a	6.48 a	11.26 a	
	16	—	0.55 d	2.29 c	3.79 a	7.13 a	0.04 d	0.97 c	3.08 b	4.87 a	8.86 a	1.22 b	3.54 a	5.75 a	10.42 a	
	24	—	—	1.30 d	2.71 c	5.84 b	—	—	1.98 d	3.68 c	7.49 a	0.08 d	2.36 c	4.43 b	8.92 a	
8" Stud	8	12	2.09 a*	3.06 a	5.16 a	6.99 a	11.01 a	2.64 a*	4.13 a	7.41 a	9.95 a	15.65 a	4.54 a	7.83 a	11.44 a	19.38 a
		16	1.95 a*	2.93 a	5.05 a	6.87 a	10.90 a	2.50 a*	3.98 a	7.26 a	9.81 a	15.51 a	4.39 a	7.69 a	11.29 a	19.21 a
		24	1.69 a*	2.67 a	4.81 a	6.64 a	10.67 a	2.21 a*	3.68 a	6.97 a	9.52 a	15.22 a	4.08 a	7.39 a	10.97 a	18.88 a
	9	12	1.98 a*	2.95 a	5.06 a	6.89 a	10.91 a	2.52 a*	4.01 a	7.28 a	9.82 a	15.52 a	4.40 a	7.67 a	11.26 a	19.15 a
		16	1.81 a*	2.79 a	4.91 a	6.74 a	10.77 a	2.34 a*	3.81 a	7.09 a	9.64 a	15.34 a	4.20 a	7.48 a	11.06 a	18.94 a
		24	1.47 a*	2.46 a	4.62 a	6.45 a	10.48 a	1.98 a*	3.44 a	6.71 a	9.27 a	14.97 a	3.81 a	7.11 a	10.66 a	18.51 a
	10	12	1.85 a*	2.83 a	4.95 a	6.77 a	10.80 a	2.38 a*	3.86 a	7.13 a	9.68 a	15.37 a	4.23 a	7.49 a	11.05 a	18.87 a
		16	1.64 a*	2.63 a	4.76 a	6.59 a	10.62 a	2.16 a*	3.63 a	6.89 a	9.45 a	15.14 a	3.99 a	7.25 a	10.80 a	18.60 a
		24	1.23 a*	2.23 a	4.39 a	6.23 a	10.26 a	1.72 a*	3.16 a	6.43 a	8.99 a	14.68 a	3.51 a	6.79 a	10.30 a	18.07 a
	12	12	1.56 a*	2.54 a	4.67 a	6.50 a	10.52 a	2.07 a*	3.52 a	6.77 a	9.32 a	15.01 a	3.85 a	7.02 a	10.53 a	18.17 a
		16	1.26 a*	2.25 a	4.40 a	6.23 a	10.25 a	1.75 a*	3.18 a	6.42 a	8.97 a	14.66 a	3.50 a	6.68 a	10.16 a	17.77 a
		24	0.69 a*	1.68 a	3.86 a	5.70 a	9.71 a	1.13 a*	2.52 a	5.74 a	8.29 a	13.97 a	2.82 a	6.02 a	9.43 a	16.97 a
	14	12	1.22 a*	2.20 a	4.33 a	6.16 a	10.16 a	1.68 a*	3.07 a	6.23 a	8.80 a	14.52 a	3.38 a	6.44 a	9.80 a	17.13 a
		16	0.83 a*	1.81 a	3.96 a	5.78 a	9.78 a	1.26 a*	2.62 a	5.76 a	8.32 a	14.02 a	2.92 a	5.99 a	9.30 a	16.57 a
		24	0.08 b*	1.06 a	3.24 a	5.05 a	9.03 a	0.46 a*	1.76 a	4.85 a	7.39 a	13.05 a	2.03 a	5.11 a	8.33 a	15.49 a
	16	12	0.84 a*	1.81 a	3.93 a	5.73 a	9.71 a	1.24 a*	2.55 a	5.50 a	7.94 a	13.52 a	2.85 a	5.75 a	8.88 a	15.73 a
		16	0.36 b*	1.32 a	3.44 a	5.24 a	9.20 a	0.73 a*	1.99 a	4.91 a	7.34 a	12.87 a	2.27 a	5.18 a	8.25 a	15.01 a
		24	—	0.40 b	2.53 a	4.31 a	8.21 a	—	0.95 a	3.81 a	6.19 a	11.62 a	1.19 a	4.10 a	7.04 a	13.64 a

See page 27 for clarification of code developed wind pressures prior to using this table.

Notes:

- For additional general notes, see page 41.
- Allowable axial loads listed in kips (1 kip = 1000 pounds).
- Allowable axial loads determined in accordance with AISI S100-16 (2020) w/ S2-20 and assuming that all axial loads pass through centroid of effective section.
- Listed tables are based on simple (single)-span.
- Studs are assumed to be adequately braced at a maximum spacing of L_u to develop full allowable moment, M_a .
- Cells marked with an "a," "b," "c," "d," "e," or "F" meet L/720, L/600, L/480, L/360, L/240, or L/120 respectively. Blank cells do not meet L/120.
- For deflection calculations, lateral loads are multiplied by 0.7 per AISI S240 except for 5psf load which is considered interior wall load.
- Cells marked with an "*" have $h/t > 200$, and thus require bearing stiffeners. Cells are left blank when $h/t > 260$.

Complies with AISI S100-16 (2020) w/S2-20 • IBC 2024

The technical content of this literature is effective 06/01/24 and supersedes all previous information.

ALLOWABLE COMBINED AXIAL & LATERAL LOADS (Kips/Stud)

Wind = 25psf		S162 (1-5/8" Flange)					S200 (2" Flange)					S250 (2-1/2" Flange)				
Stud length (ft)	Spacing (in) o.c.	-33	-43	-54	-68	-97	-33	-43	-54	-68	-97	-43	-54	-68	-97	
		(20ga) 33ksi	(18ga) 33ksi	(16ga) 50ksi	(14ga) 50ksi	(12ga) 50ksi	(20ga) 33ksi	(18ga) 33ksi	(16ga) 50ksi	(14ga) 50ksi	(12ga) 50ksi	(18ga) 33ksi	(16ga) 50ksi	(14ga) 50ksi	(12ga) 50ksi	
3-5/8" Stud	8	12	1.02 a	1.78 a	3.33 a	4.55 a	6.95 a	1.34 a	2.34 a	4.27 a	5.78 a	8.60 a	2.71 a	4.85 a	6.77 a	10.11 a
		16	0.71 a	1.46 a	3.02 a	4.24 a	6.59 a	1.00 a	1.99 a	3.92 a	5.43 a	8.23 a	2.33 a	4.48 a	6.38 a	9.74 a
		24	0.14 c	0.85 b	2.44 a	3.63 a	5.92 a	0.37 c	1.32 a	3.26 a	4.77 a	7.53 a	1.61 a	3.77 a	5.65 a	9.04 a
	9	12	0.73 b	1.43 a	2.86 a	3.98 a	6.15 a	1.00 a	1.93 a	3.68 a	5.07 a	7.65 a	2.28 a	4.27 a	5.96 a	9.07 a
		16	0.37 c	1.06 b	2.50 a	3.60 a	5.73 a	0.61 c	1.52 a	3.28 a	4.66 a	7.21 a	1.83 a	3.82 a	5.50 a	8.63 a
		24	—	0.38 d	1.84 c	2.92 b	4.94 a	—	0.77 c	2.54 b	3.91 a	6.39 a	1.01 b	3.01 a	4.66 a	7.80 a
	10	12	0.44 c	1.09 b	2.39 a	3.38 a	5.31 a	0.68 c	1.52 a	3.10 a	4.34 a	6.67 a	1.84 a	3.67 a	5.13 a	7.99 a
		16	0.06 d	0.68 d	1.99 c	2.97 a	4.85 a	0.25 d	1.07 c	2.65 b	3.89 a	6.18 a	1.34 b	3.18 a	4.62 a	7.49 a
		24	—	—	1.29 d	2.23 c	4.00 b	—	0.27 d	1.86 d	3.08 c	5.28 a	0.45 d	2.28 c	3.71 b	6.56 a
	12	12	—	0.47 d	1.50 d	2.27 c	3.73 a	0.11 e	0.79 d	2.01 c	2.99 b	4.79 a	1.01 c	2.44 b	3.58 a	5.88 a
		16	—	0.03 e	1.09 e	1.84 d	3.23 c	—	0.30 e	1.55 d	2.51 c	4.26 b	0.46 d	1.92 d	3.04 c	5.32 a
		24	—	—	0.38 f	1.08 e	2.35 d	—	—	0.74 e	1.68 e	3.32 d	—	1.00 e	2.09 d	4.33 c
14	12	—	—	0.84 e	1.43 e	2.50 d	—	0.22 e	1.20 e	1.95 d	3.31 c	0.35 e	1.48 d	2.37 c	4.18 b	
	16	—	—	0.45 f	1.01 e	2.02 e	—	—	0.75 e	1.49 e	2.80 d	—	0.98 e	1.85 d	3.63 c	
	24	—	—	—	0.29 f	1.19 f	—	—	—	0.70 f	1.90 e	—	0.11 f	0.94 e	2.66 e	
16	12	—	—	0.38 f	0.84 f	1.64 e	—	—	0.63 f	1.22 e	2.26 d	—	0.82 e	1.51 e	2.94 d	
	16	—	—	0.01 f	0.45 f	1.19 f	—	—	0.22 f	0.79 f	1.78 e	—	0.34 f	1.02 e	2.42 e	
	24	—	—	—	—	0.42 f	—	—	—	0.05 f	0.94 f	—	—	0.17 f	1.51 f	
4" Stud	8	12	1.22 a	2.05 a	3.83 a	5.37 a	8.19 a	1.55 a	2.66 a	4.89 a	6.74 a	10.11 a	3.05 a	5.40 a	7.75 a	11.84 a
		16	0.91 a	1.73 a	3.52 a	5.05 a	7.83 a	1.22 a	2.32 a	4.55 a	6.39 a	9.74 a	2.69 a	5.06 a	7.38 a	11.47 a
		24	0.34 b	1.14 a	2.94 a	4.43 a	7.16 a	0.60 b	1.67 a	3.89 a	5.72 a	9.04 a	2.00 a	4.40 a	6.67 a	10.76 a
	9	12	0.93 a	1.72 a	3.38 a	4.83 a	7.43 a	1.23 a	2.27 a	4.34 a	6.08 a	9.19 a	2.65 a	4.93 a	7.10 a	10.83 a
		16	0.57 b	1.34 a	3.02 a	4.44 a	7.00 a	0.84 a	1.87 a	3.92 a	5.65 a	8.75 a	2.22 a	4.50 a	6.64 a	10.38 a
		24	—	0.66 c	2.34 b	3.72 a	6.19 a	0.14 c	1.11 b	3.16 a	4.86 a	7.90 a	1.41 a	3.71 a	5.78 a	9.51 a
	10	12	0.64 b	1.37 a	2.92 a	4.25 a	6.60 a	0.90 a	1.87 a	3.75 a	5.37 a	8.21 a	2.23 a	4.37 a	6.35 a	9.75 a
		16	0.24 d	0.95 b	2.50 a	3.80 a	6.10 a	0.47 c	1.41 b	3.29 a	4.88 a	7.69 a	1.74 a	3.87 a	5.82 a	9.21 a
		24	—	0.20 d	1.75 c	3.00 b	5.19 a	—	0.58 d	2.45 c	3.99 b	6.73 a	0.84 c	2.98 b	4.84 a	8.22 a
	12	12	0.11 d	0.72 d	2.00 c	3.05 b	4.91 a	0.30 d	1.10 c	2.62 b	3.93 a	6.22 a	1.40 b	3.21 a	4.72 a	7.52 a
		16	—	0.24 e	1.53 d	2.55 c	4.34 b	—	0.58 d	2.11 c	3.38 b	5.62 a	0.82 d	2.63 c	4.11 a	6.90 a
		24	—	—	0.73 e	1.68 e	3.35 d	—	—	1.20 e	2.41 d	4.55 c	—	1.62 d	3.03 c	5.77 b
	14	12	—	0.18 e	1.22 e	2.01 d	3.42 c	—	0.45 e	1.67 d	2.67 c	4.45 b	0.66 d	2.10 c	3.26 b	5.51 a
		16	—	—	0.76 e	1.52 e	2.86 d	—	—	1.16 e	2.12 d	3.85 c	0.07 e	1.53 d	2.66 d	4.86 b
		24	—	—	—	0.68 f	1.90 e	—	—	0.28 f	1.19 e	2.80 e	—	0.54 e	1.61 e	3.74 d
	16	12	—	—	0.65 e	1.26 e	2.32 d	—	—	0.97 e	1.74 e	3.12 d	0.09 e	1.28 e	2.18 d	3.95 c
		16	—	—	0.21 f	0.79 f	1.80 e	—	—	0.49 f	1.23 e	2.55 e	—	0.73 e	1.60 e	3.33 d
		24	—	—	—	0.01 f	0.90 f	—	—	—	0.36 f	1.57 f	—	—	0.62 f	2.27 e

See page 27 for clarification of code developed wind pressures prior to using this table.

Notes:

- 1 For additional general notes, see page 41.
- 2 Allowable axial loads listed in kips (1 kip = 1000 pounds).
- 3 Allowable axial loads determined in accordance with AISI S100-16 (2020) w/ S2-20 and assuming that all axial loads pass through centroid of effective section.
- 4 Listed tables are based on simple (single)-span.
- 5 Studs are assumed to be adequately braced at a maximum spacing of Lu to develop full allowable moment, Ma.
- 6 Cells marked with an "a," "b," "c," "d," "e," or "f" meet L/720, L/600, L/480, L/360, L/240, or L/120 respectively. Blank cells do not meet L/120.
- 7 For deflection calculations, lateral loads are multiplied by 0.7 per AISI S240 except for 5psf load which is considered interior wall load.
- 8 Cells marked with an "*" have h/t > 200, and thus require bearing stiffeners. Cells are left blank when h/t > 260.

Complies with AISI S100-16 (2020) w/S2-20 • IBC 2024

ALLOWABLE COMBINED AXIAL & LATERAL LOADS

(Kips/Stud)

Wind = 25psf		S162 (1-5/8" Flange)					S200 (2" Flange)					S250 (2-1/2" Flange)				
Stud length (ft)	Spacing (in) o.c.	-33	-43	-54	-68	-97	-33	-43	-54	-68	-97	-43	-54	-68	-97	
		(20ga) 33ksi	(18ga) 33ksi	(16ga) 50ksi	(14ga) 50ksi	(12ga) 50ksi	(20ga) 33ksi	(18ga) 33ksi	(16ga) 50ksi	(14ga) 50ksi	(12ga) 50ksi	(18ga) 33ksi	(16ga) 50ksi	(14ga) 50ksi	(12ga) 50ksi	
6" Stud	8	12	1.84 a	2.83 a	5.07 a	6.91 a	10.85 a	2.27 a	3.68 a	6.83 a	9.33 a	14.98 a	4.01 a	7.04 a	10.4 a	17.55 a
		16	1.61 a	2.60 a	4.85 a	6.70 a	10.63 a	2.03 a	3.43 a	6.58 a	9.08 a	14.71 a	3.76 a	6.79 a	10.13 a	17.26 a
		24	1.16 a	2.16 a	4.43 a	6.27 a	10.19 a	1.57 a	2.93 a	6.07 a	8.57 a	14.19 a	3.25 a	6.30 a	9.60 a	16.69 a
	9	12	1.65 a	2.63 a	4.87 a	6.71 a	10.64 a	2.05 a	3.43 a	6.51 a	8.97 a	14.52 a	3.76 a	6.73 a	10.00 a	16.98 a
		16	1.36 a	2.34 a	4.60 a	6.44 a	10.35 a	1.76 a	3.11 a	6.18 a	8.64 a	14.18 a	3.44 a	6.42 a	9.66 a	16.61 a
		24	0.80 a	1.79 a	4.06 a	5.89 a	9.79 a	1.18 a	2.49 a	5.55 a	8.00 a	13.50 a	2.80 a	5.81 a	8.99 a	15.87 a
	10	12	1.43 a	2.41 a	4.64 a	6.48 a	10.39 a	1.81 a	3.15 a	6.13 a	8.54 a	13.97 a	3.47 a	6.38 a	9.55 a	16.31 a
		16	1.08 a	2.06 a	4.30 a	6.13 a	10.03 a	1.45 a	2.76 a	5.73 a	8.14 a	13.54 a	3.08 a	6.00 a	9.12 a	15.84 a
		24	0.41 a	1.39 a	3.64 a	5.46 a	9.32 a	0.77 a	2.02 a	4.97 a	7.35 a	12.70 a	2.31 a	5.25 a	8.30 a	14.93 a
	12	12	0.92 a	1.87 a	4.05 a	5.90 a	9.75 a	1.27 a	2.50 a	5.24 a	7.51 a	12.58 a	2.82 a	5.55 a	8.46 a	14.66 a
		16	0.46 b	1.40 a	3.56 a	5.40 a	9.20 a	0.80 a	1.98 a	4.70 a	6.94 a	11.96 a	2.28 a	5.02 a	7.87 a	14.00 a
		24	—	0.52 b	2.66 a	4.45 a	8.17 a	—	1.02 b	3.69 a	5.88 a	10.80 a	1.27 a	4.02 a	6.75 a	12.73 a
14	12	0.39 c	1.27 a	3.25 a	4.97 a	8.85 a	0.71 b	1.80 a	4.23 a	6.29 a	10.88 a	2.10 a	4.62 a	7.21 a	12.71 a	
	16	—	0.70 c	2.66 b	4.34 a	8.11 a	0.14 c	1.17 b	3.58 a	5.60 a	10.09 a	1.44 a	3.96 a	6.47 a	11.86 a	
	24	—	—	1.60 d	3.19 c	6.76 a	—	0.05 d	2.40 c	4.33 b	8.66 a	0.24 c	2.75 b	5.10 a	10.29 a	
16	12	—	0.68 c	2.42 b	3.94 a	7.30 a	0.17 d	1.11 c	3.23 a	5.03 a	9.04 a	1.37 b	3.70 a	5.92 a	10.63 a	
	16	—	0.05 d	1.78 d	3.23 c	6.46 a	—	0.42 d	2.51 c	4.26 b	8.15 a	0.63 c	2.93 b	5.07 a	9.65 a	
	24	—	—	0.63 e	1.98 d	4.98 c	—	—	1.24 d	2.88 d	6.56 b	—	1.57 d	3.55 c	7.91 b	
8" Stud	8	12	1.99 a*	2.96 a	5.08 a	6.90 a	10.92 a	2.53 a*	4.02 a	7.30 a	9.84 a	15.54 a	4.42 a	7.72 a	11.32 a	19.26 a
		16	1.82 a*	2.80 a	4.93 a	6.76 a	10.78 a	2.35 a*	3.83 a	7.11 a	9.66 a	15.36 a	4.23 a	7.54 a	11.13 a	19.05 a
		24	1.49 a*	2.48 a	4.64 a	6.47 a	10.50 a	2.00 a*	3.46 a	6.75 a	9.30 a	15.01 a	3.85 a	7.17 a	10.74 a	18.63 a
	9	12	1.85 a*	2.83 a	4.95 a	6.78 a	10.80 a	2.38 a*	3.86 a	7.14 a	9.69 a	15.38 a	4.25 a	7.53 a	11.11 a	18.99 a
		16	1.64 a*	2.63 a	4.76 a	6.59 a	10.62 a	2.16 a*	3.63 a	6.90 a	9.45 a	15.16 a	4.00 a	7.30 a	10.86 a	18.72 a
		24	1.22 a*	2.22 a	4.39 a	6.23 a	10.26 a	1.71 a*	3.16 a	6.43 a	9.00 a	14.70 a	3.52 a	6.83 a	10.36 a	18.19 a
	10	12	1.69 a*	2.68 a	4.81 a	6.64 a	10.66 a	2.22 a*	3.68 a	6.95 a	9.50 a	15.20 a	4.05 a	7.31 a	10.87 a	18.67 a
		16	1.43 a*	2.43 a	4.58 a	6.41 a	10.44 a	1.94 a*	3.39 a	6.66 a	9.21 a	14.91 a	3.75 a	7.02 a	10.55 a	18.34 a
		24	0.93 a*	1.93 a	4.12 a	5.96 a	9.99 a	1.39 a*	2.81 a	6.08 a	8.64 a	14.34 a	3.15 a	6.44 a	9.93 a	17.67 a
	12	12	1.33 a*	2.32 a	4.47 a	6.30 a	10.32 a	1.83 a*	3.27 a	6.51 a	9.06 a	14.74 a	3.58 a	6.77 a	10.25 a	17.87 a
		16	0.97 a*	1.97 a	4.13 a	5.96 a	9.98 a	1.44 a*	2.85 a	6.08 a	8.63 a	14.31 a	3.15 a	6.35 a	9.80 a	17.37 a
		24	0.27 a*	1.27 a	3.47 a	5.30 a	9.32 a	0.68 a*	2.03 a	5.24 a	7.80 a	13.46 a	2.32 a	5.53 a	8.90 a	16.39 a
	14	12	0.92 a*	1.91 a	4.05 a	5.87 a	9.87 a	1.36 a*	2.73 a	5.88 a	8.44 a	14.14 a	3.03 a	6.10 a	9.42 a	16.71 a
		16	0.45 a*	1.43 a	3.59 a	5.41 a	9.40 a	0.85 a*	2.18 a	5.30 a	7.85 a	13.53 a	2.47 a	5.54 a	8.81 a	16.03 a
		24	—	0.53 a	2.71 a	4.53 a	8.49 a	—	1.14 a	4.20 a	6.73 a	12.34 a	1.39 a	4.47 a	7.62 a	14.70 a
	16	12	0.47 a*	1.44 a	3.56 a	5.36 a	9.32 a	0.86 a*	2.13 a	5.05 a	7.49 a	13.03 a	2.41 a	5.32 a	8.40 a	15.19 a
		16	—	0.85 a	2.98 a	4.77 a	8.70 a	0.25 b*	1.46 a	4.35 a	6.76 a	12.24 a	1.72 a	4.63 a	7.63 a	14.32 a
		24	—	—	1.89 b	3.64 a	7.51 a	—	0.22 c	3.03 a	5.38 a	10.74 a	0.43 b	3.33 a	6.18 a	12.67 a

See page 27 for clarification of code developed wind pressures prior to using this table.

Notes:

- 1 For additional general notes, see page 41.
- 2 Allowable axial loads listed in kips (1 kip = 1000 pounds).
- 3 Allowable axial loads determined in accordance with AISI S100-16 (2020) w/ S2-20 and assuming that all axial loads pass through centroid of effective section.
- 4 Listed tables are based on simple (single)-span.
- 5 Studs are assumed to be adequately braced at a maximum spacing of Lu to develop full allowable moment, Ma.
- 6 Cells marked with an "a," "b," "c," "d," "e," or "F" meet L/720, L/600, L/480, L/360, L/240, or L/120 respectively. Blank cells do not meet L/120.
- 7 For deflection calculations, lateral loads are multiplied by 0.7 per AISI S240 except for 5psf load which is considered interior wall load.
- 8 Cells marked with an "*" have h/t > 200, and thus require bearing stiffeners. Cells are left blank when h/t > 260.

Complies with AISI S100-16 (2020) w/S2-20 • IBC 2024

The technical content of this literature is effective 06/01/24 and supersedes all previous information.

ALLOWABLE COMBINED AXIAL & LATERAL LOADS (Kips/Stud)

Wind = 30psf		S162 (1-5/8" Flange)					S200 (2" Flange)					S250 (2-1/2" Flange)				
Stud length (ft)	Spacing (in) o.c.	-33	-43	-54	-68	-97	-33	-43	-54	-68	-97	-43	-54	-68	-97	
		(20ga) 33ksi	(18ga) 33ksi	(16ga) 50ksi	(14ga) 50ksi	(12ga) 50ksi	(20ga) 33ksi	(18ga) 33ksi	(16ga) 50ksi	(14ga) 50ksi	(12ga) 50ksi	(18ga) 33ksi	(16ga) 50ksi	(14ga) 50ksi	(12ga) 50ksi	
3-5/8" Stud	8	12	0.84 a	1.58 a	3.14 a	4.36 a	6.73 a	1.13 a	2.13 a	4.06 a	5.57 a	8.38 a	2.48 a	4.62 a	6.53 a	9.89 a
		16	0.48 b	1.21 a	2.78 a	3.99 a	6.32 a	0.74 b	1.71 a	3.65 a	5.16 a	7.95 a	2.03 a	4.19 a	6.08 a	9.46 a
		24	—	0.52 c	2.11 b	3.29 a	5.53 a	0.02 d	0.95 b	2.89 a	4.40 a	7.13 a	1.21 b	3.37 a	5.23 a	8.63 a
	9	12	0.51 c	1.20 a	2.64 a	3.75 a	5.89 a	0.76 b	1.68 a	3.44 a	4.82 a	7.38 a	2.01 a	4.00 a	5.68 a	8.80 a
		16	0.11 d	0.78 c	2.23 b	3.32 a	5.41 a	0.32 c	1.21 b	2.97 a	4.35 a	6.88 a	1.49 a	3.49 a	5.15 a	8.29 a
		24	—	0.01 d	1.48 d	2.53 c	4.51 a	—	0.36 d	2.13 c	3.49 b	5.93 a	0.56 c	2.56 b	4.18 a	7.33 a
	10	12	0.21 d	0.84 c	2.15 b	3.13 a	5.03 a	0.42 c	1.25 b	2.83 a	4.07 a	6.37 a	1.54 a	3.37 a	4.82 a	7.68 a
		16	—	0.37 d	1.70 c	2.66 b	4.49 a	—	0.74 d	2.32 c	3.55 b	5.80 a	0.97 c	2.81 b	4.24 a	7.10 a
		24	—	—	0.90 e	1.83 d	3.53 c	—	—	1.43 d	2.63 d	4.78 b	—	1.80 d	3.20 c	6.05 a
	12	12	—	0.20 e	1.25 d	2.01 d	3.42 b	—	0.49 d	1.73 d	2.70 c	4.46 a	0.67 d	2.12 c	3.25 b	5.54 a
		16	—	—	0.79 e	1.52 e	2.86 d	—	—	1.21 e	2.16 d	3.86 c	0.06 e	1.53 d	2.64 c	4.91 b
		24	—	—	—	0.68 f	1.88 e	—	—	0.32 f	1.23 e	2.81 d	—	0.51 e	1.58 e	3.80 d
14	12	—	—	0.60 f	1.17 e	2.21 d	—	—	0.92 e	1.67 e	3.00 d	0.01 e	1.17 e	2.05 d	3.84 c	
	16	—	—	0.16 f	0.71 f	1.67 e	—	—	0.43 f	1.16 e	2.42 e	—	0.61 e	1.46 e	3.22 d	
	24	—	—	—	—	0.75 f	—	—	—	0.28 f	1.42 f	—	—	0.45 f	2.15 e	
16	12	—	—	0.16 f	0.60 f	1.36 e	—	—	0.38 f	0.96 f	1.96 e	—	0.53 f	1.21 e	2.62 d	
	16	—	—	—	0.16 f	0.87 f	—	—	—	0.48 f	1.42 f	—	—	0.66 f	2.04 e	
	24	—	—	—	—	0.02 f	—	—	—	0.50 f	—	—	—	—	1.04 f	
4" Stud	8	12	1.04 a	1.86 a	3.64 a	5.17 a	7.97 a	1.35 a	2.46 a	4.68 a	6.53 a	9.89 a	2.83 a	5.19 a	7.52 a	11.62 a
		16	0.68 a	1.49 a	3.28 a	4.80 a	7.56 a	0.97 a	2.05 a	4.28 a	6.12 a	9.45 a	2.41 a	4.79 a	7.09 a	11.19 a
		24	0.02 c	0.80 b	2.61 a	4.08 a	6.76 a	0.26 c	1.30 a	3.52 a	5.34 a	8.63 a	1.61 a	4.02 a	6.26 a	10.34 a
	9	12	0.71 b	1.49 a	3.16 a	4.59 a	7.17 a	0.99 a	2.03 a	4.09 a	5.82 a	8.92 a	2.39 a	4.67 a	6.82 a	10.56 a
		16	0.31 c	1.06 b	2.74 a	4.14 a	6.67 a	0.55 b	1.55 a	3.61 a	5.33 a	8.40 a	1.89 a	4.18 a	6.29 a	10.02 a
		24	—	0.28 d	1.96 c	3.31 b	5.73 a	—	0.69 c	2.73 b	4.41 a	7.42 a	0.96 b	3.26 a	5.30 a	9.02 a
	10	12	0.40 c	1.12 b	2.66 a	3.98 a	6.30 a	0.64 b	1.59 a	3.47 a	5.07 a	7.90 a	1.93 a	4.07 a	6.03 a	9.42 a
		16	—	0.64 c	2.19 b	3.47 a	5.73 a	0.15 d	1.07 c	2.94 a	4.51 a	7.30 a	1.36 b	3.50 a	5.42 a	8.81 a
		24	—	—	1.34 d	2.55 c	4.69 b	—	0.13 d	1.98 c	3.50 c	6.20 a	0.34 d	2.48 c	4.30 b	7.66 a
	12	12	—	0.43 d	1.71 d	2.74 c	4.56 a	—	0.78 d	2.31 c	3.59 b	5.85 a	1.05 c	2.86 b	4.34 a	7.14 a
		16	—	—	1.20 e	2.18 d	3.93 c	—	0.20 e	1.73 d	2.97 c	5.17 b	0.40 d	2.21 c	3.66 b	6.43 a
		24	—	—	0.29 f	1.21 e	2.81 d	—	—	0.71 e	1.89 e	3.97 d	—	1.08 e	2.45 d	5.15 c
	14	12	—	—	0.94 e	1.71 d	3.08 c	—	0.13 e	1.36 e	2.33 d	4.08 c	0.30 e	1.75 d	2.89 c	5.11 b
		16	—	—	0.43 f	1.17 e	2.46 d	—	—	0.79 e	1.73 e	3.41 d	—	1.11 e	2.22 d	4.39 c
		24	—	—	—	0.23 f	1.38 e	—	—	—	0.69 f	2.25 e	—	0.02 f	1.05 e	3.14 e
	16	12	—	—	0.38 f	0.97 e	2.00 e	—	—	0.68 f	1.43 e	2.77 d	—	0.94 e	1.82 e	3.57 d
		16	—	—	—	0.46 f	1.42 e	—	—	0.14 f	0.86 f	2.13 e	—	0.34 f	1.19 e	2.89 e
		24	—	—	—	—	0.42 f	—	—	—	—	1.05 f	—	—	0.10 f	1.71 f

See page 27 for clarification of code developed wind pressures prior to using this table.

Notes:

- 1 For additional general notes, see page 41.
- 2 Allowable axial loads listed in kips (1 kip = 1000 pounds).
- 3 Allowable axial loads determined in accordance with AISI S100-16 (2020) w/ S2-20 and assuming that all axial loads pass through centroid of effective section.
- 4 Listed tables are based on simple (single)-span.
- 5 Studs are assumed to be adequately braced at a maximum spacing of Lu to develop full allowable moment, Ma.
- 6 Cells marked with an "a," "b," "c," "d," "e," or "f" meet L/720, L/600, L/480, L/360, L/240, or L/120 respectively. Blank cells do not meet L/120.
- 7 For deflection calculations, lateral loads are multiplied by 0.7 per AISI S240 except for 5psf load which is considered interior wall load.
- 8 Cells marked with an "*" have h/t > 200, and thus require bearing stiffeners. Cells are left blank when h/t > 260.

Complies with AISI S100-16 (2020) w/S2-20 • IBC 2024

ALLOWABLE COMBINED AXIAL & LATERAL LOADS (Kips/Stud)

Wind = 30psf		S162 (1-5/8" Flange)					S200 (2" Flange)					S250 (2-1/2" Flange)					
Stud length (ft)	Spacing (in) o.c.	-33	-43	-54	-68	-97	-33	-43	-54	-68	-97	-43	-54	-68	-97		
		(20ga) 33ksi	(18ga) 33ksi	(16ga) 50ksi	(14ga) 50ksi	(12ga) 50ksi	(20ga) 33ksi	(18ga) 33ksi	(16ga) 50ksi	(14ga) 50ksi	(12ga) 50ksi	(18ga) 33ksi	(16ga) 50ksi	(14ga) 50ksi	(12ga) 50ksi		
6" Stud	8	12	1.70 a	2.69 a	4.94 a	6.78 a	10.71 a	2.13 a	3.53 a	6.68 a	9.18 a	14.82 a	3.86 a	6.89 a	10.24 a	17.38 a	
		16	1.43 a	2.42 a	4.68 a	6.52 a	10.45 a	1.84 a	3.23 a	6.37 a	8.87 a	14.50 a	3.55 a	6.59 a	9.92 a	17.03 a	
		24	0.90 a	1.89 a	4.17 a	6.02 a	9.93 a	1.29 a	2.64 a	5.77 a	8.27 a	13.87 a	2.95 a	6.01 a	9.28 a	16.35 a	
	9	12	1.47 a	2.46 a	4.71 a	6.55 a	10.47 a	1.87 a	3.24 a	6.31 a	8.77 a	14.31 a	3.56 a	6.54 a	9.80 a	16.76 a	
		16	1.13 a	2.12 a	4.38 a	6.22 a	10.13 a	1.52 a	2.86 a	5.93 a	8.38 a	13.91 a	3.18 a	6.17 a	9.39 a	16.31 a	
		24	0.48 a	1.46 a	3.74 a	5.57 a	9.46 a	0.84 a	2.13 a	5.18 a	7.62 a	13.10 a	2.43 a	5.44 a	8.59 a	15.44 a	
	10	12	1.22 a	2.20 a	4.44 a	6.27 a	10.17 a	1.59 a	2.91 a	5.89 a	8.30 a	13.71 a	3.23 a	6.15 a	9.29 a	16.03 a	
		16	0.81 a	1.79 a	4.03 a	5.86 a	9.74 a	1.17 a	2.46 a	5.42 a	7.82 a	13.20 a	2.77 a	5.69 a	8.79 a	15.48 a	
		24	0.03 b	1.00 a	3.25 a	5.07 a	8.91 a	0.37 a	1.59 a	4.52 a	6.90 a	12.21 a	1.87 a	4.81 a	7.82 a	14.40 a	
	12	12	0.64 a	1.58 a	3.75 a	5.60 a	9.42 a	0.98 a	2.19 a	4.91 a	7.17 a	12.21 a	2.49 a	5.23 a	8.10 a	14.26 a	
		16	0.12 c	1.03 a	3.20 a	5.01 a	8.78 a	0.44 b	1.59 a	4.29 a	6.51 a	11.49 a	1.87 a	4.61 a	7.41 a	13.48 a	
		24	—	0.02 c	2.15 b	3.91 a	7.58 a	—	0.47 c	3.12 b	5.28 a	10.13 a	0.70 b	3.44 a	6.11 a	12.00 a	
	14	12	0.07 c	0.92 b	2.89 a	4.58 a	8.40 a	0.36 c	1.42 a	3.84 a	5.87 a	10.40 a	1.70 a	4.22 a	6.76 a	12.19 a	
		16	—	0.27 d	2.22 c	3.86 a	7.55 a	—	0.71 c	3.09 b	5.07 a	9.50 a	0.94 b	3.46 a	5.90 a	11.21 a	
		24	—	—	1.01 d	2.56 c	6.02 b	—	—	1.75 d	3.63 c	7.86 a	—	2.07 c	4.35 b	9.42 a	
	16	12	—	0.29 d	2.03 c	3.50 b	6.79 a	—	0.69 c	2.79 b	4.56 a	8.50 a	0.92 c	3.23 b	5.40 a	10.03 a	
		16	—	—	1.30 d	2.71 c	5.84 b	—	—	1.98 d	3.68 c	7.49 a	0.08 d	2.36 c	4.43 b	8.92 a	
		24	—	—	0.02 e	1.31 e	4.18 d	—	—	0.56 e	2.14 d	5.70 c	—	0.84 e	2.73 d	6.96 c	
	8" Stud	8	12	1.89 a*	2.87 a	4.99 a	6.81 a	10.84 a	2.42 a*	3.91 a	7.19 a	9.73 a	15.43 a	4.31 a	7.61 a	11.21 a	19.13 a
			16	1.69 a*	2.67 a	4.81 a	6.64 a	10.67 a	2.21 a*	3.68 a	6.97 a	9.52 a	15.22 a	4.08 a	7.39 a	10.97 a	18.88 a
			24	1.29 a*	2.29 a	4.46 a	6.30 a	10.34 a	1.79 a*	3.24 a	6.53 a	9.09 a	14.80 a	3.62 a	6.95 a	10.50 a	18.39 a
		9	12	1.72 a*	2.71 a	4.84 a	6.67 a	10.69 a	2.25 a*	3.72 a	7.00 a	9.55 a	15.25 a	4.10 a	7.39 a	10.96 a	18.83 a
			16	1.47 a*	2.46 a	4.62 a	6.45 a	10.48 a	1.98 a*	3.44 a	6.71 a	9.27 a	14.97 a	3.81 a	7.11 a	10.66 a	18.51 a
			24	0.98 a*	1.98 a	4.17 a	6.01 a	10.05 a	1.45 a*	2.88 a	6.16 a	8.72 a	14.43 a	3.23 a	6.55 a	10.07 a	17.87 a
10		12	1.54 a*	2.53 a	4.67 a	6.50 a	10.53 a	2.05 a*	3.51 a	6.78 a	9.33 a	15.03 a	3.87 a	7.13 a	10.68 a	18.47 a	
		16	1.23 a*	2.23 a	4.39 a	6.23 a	10.26 a	1.72 a*	3.16 a	6.43 a	8.99 a	14.68 a	3.51 a	6.79 a	10.30 a	18.07 a	
		24	0.63 a*	1.64 a	3.84 a	5.69 a	9.72 a	1.07 a*	2.47 a	5.73 a	8.30 a	14.00 a	2.80 a	6.10 a	9.57 a	17.27 a	
12		12	1.12 a*	2.11 a	4.26 a	6.10 a	10.11 a	1.59 a*	3.01 a	6.25 a	8.80 a	14.48 a	3.33 a	6.52 a	9.98 a	17.57 a	
		16	0.69 a*	1.68 a	3.86 a	5.70 a	9.71 a	1.13 a*	2.52 a	5.74 a	8.29 a	13.97 a	2.82 a	6.02 a	9.43 a	16.97 a	
		24	—	0.86 a	3.08 a	4.92 a	8.93 a	0.24 a*	1.56 a	4.75 a	7.31 a	12.95 a	1.83 a	5.05 a	8.38 a	15.81 a	
14		12	0.64 a*	1.62 a	3.77 a	5.60 a	9.59 a	1.06 a*	2.40 a	5.53 a	8.08 a	13.77 a	2.69 a	5.76 a	9.05 a	16.30 a	
		16	0.08 b*	1.06 a	3.24 a	5.05 a	9.03 a	0.46 a*	1.76 a	4.85 a	7.39 a	13.05 a	2.03 a	5.11 a	8.33 a	15.49 a	
		24	—	0.01 b	2.21 a	4.01 a	7.96 a	—	0.54 a	3.57 a	6.08 a	11.65 a	0.77 a	3.85 a	6.94 a	13.94 a	
16		12	0.12 b*	1.08 a	3.21 a	5.00 a	8.95 a	0.49 a*	1.72 a	4.62 a	7.04 a	12.55 a	1.99 a	4.90 a	7.94 a	14.66 a	
		16	—	0.40 b	2.53 a	4.31 a	8.21 a	—	0.95 a	3.81 a	6.19 a	11.62 a	1.19 a	4.10 a	7.04 a	13.64 a	
		24	—	—	1.27 c	3.01 b	6.83 a	—	—	2.29 b	4.61 a	9.88 a	—	2.60 b	5.36 a	11.73 a	

See page 27 for clarification of code developed wind pressures prior to using this table.

Notes:

- 1 For additional general notes, see page 41.
- 2 Allowable axial loads listed in kips (1 kip = 1000 pounds).
- 3 Allowable axial loads determined in accordance with AISI S100-16 (2020) w/ S2-20 and assuming that all axial loads pass through centroid of effective section.
- 4 Listed tables are based on simple (single)-span.
- 5 Studs are assumed to be adequately braced at a maximum spacing of L_u to develop full allowable moment, M_a .
- 6 Cells marked with an "a," "b," "c," "d," "e," or "F" meet L/720, L/600, L/480, L/360, L/240, or L/120 respectively. Blank cells do not meet L/120.
- 7 For deflection calculations, lateral loads are multiplied by 0.7 per AISI S240 except for 5psf load which is considered interior wall load.
- 8 Cells marked with an "*" have $h/t > 200$, and thus require bearing stiffeners. Cells are left blank when $h/t > 260$.

Complies with AISI S100-16 (2020) w/S2-20 • IBC 2024

The technical content of this literature is effective 06/01/24 and supersedes all previous information.

ALLOWABLE COMBINED AXIAL & LATERAL LOADS (Kips/Stud)

Wind = 35psf		S162 (1-5/8" Flange)					S200 (2" Flange)					S250 (2-1/2" Flange)				
Stud length (ft)	Spacing (in) o.c.	-33	-43	-54	-68	-97	-33	-43	-54	-68	-97	-43	-54	-68	-97	
		(20ga) 33ksi	(18ga) 33ksi	(16ga) 50ksi	(14ga) 50ksi	(12ga) 50ksi	(20ga) 33ksi	(18ga) 33ksi	(16ga) 50ksi	(14ga) 50ksi	(12ga) 50ksi	(18ga) 33ksi	(16ga) 50ksi	(14ga) 50ksi	(12ga) 50ksi	
3-5/8" Stud	8	12	0.65 b	1.39 a	2.96 a	4.17 a	6.52 a	0.93 a	1.92 a	3.85 a	5.36 a	8.16 a	2.25 a	4.40 a	6.31 a	9.67 a
		16	0.25 c	0.97 b	2.55 a	3.75 a	6.05 a	0.49 b	1.45 a	3.39 a	4.90 a	7.67 a	1.75 a	3.91 a	5.79 a	9.18 a
		24	—	0.19 d	1.80 c	2.96 b	5.16 a	—	0.60 c	2.54 b	4.04 a	6.73 a	0.82 b	2.99 a	4.82 a	8.24 a
	9	12	0.31 c	0.99 b	2.43 a	3.53 a	5.65 a	0.54 c	1.44 a	3.20 a	4.58 a	7.13 a	1.74 a	3.74 a	5.41 a	8.54 a
		16	—	0.51 d	1.97 c	3.05 b	5.10 a	0.05 d	0.92 c	2.68 b	4.05 a	6.55 a	1.17 b	3.17 a	4.82 a	7.96 a
		24	—	—	1.14 d	2.17 d	4.09 b	—	—	1.74 d	3.08 c	5.49 a	0.13 d	2.13 c	3.73 b	6.87 a
	10	12	—	0.60 d	1.92 c	2.89 b	4.76 a	0.17 d	0.99 c	2.57 b	3.81 a	6.08 a	1.25 b	3.08 a	4.53 a	7.39 a
		16	—	0.09 e	1.42 d	2.37 c	4.16 b	—	0.42 d	2.01 c	3.23 b	5.45 a	0.62 d	2.45 c	3.88 b	6.74 a
		24	—	—	0.54 e	1.44 e	3.09 d	—	—	1.02 e	2.21 d	4.31 c	—	1.34 d	2.73 d	5.56 b
	12	12	—	—	1.01 e	1.76 d	3.13 c	—	0.21 e	1.46 d	2.42 d	4.16 b	0.36 d	1.82 d	2.94 c	5.22 a
		16	—	—	0.51 e	1.22 e	2.52 d	—	—	0.90 e	1.83 e	3.49 d	—	1.17 e	2.26 d	4.52 c
		24	—	—	—	0.30 f	1.45 e	—	—	—	0.81 f	2.34 e	—	0.06 f	1.10 e	3.29 d
14	12	—	—	0.37 f	0.93 e	1.93 e	—	—	0.67 e	1.41 e	2.70 d	—	0.88 e	1.75 e	3.52 d	
	16	—	—	—	0.43 f	1.35 e	—	—	0.14 f	0.85 f	2.07 e	—	0.27 f	1.11 e	2.85 e	
	24	—	—	—	—	0.35 f	—	—	—	—	0.98 f	—	—	0.01 f	1.67 f	
16	12	—	—	—	0.37 f	1.11 f	—	—	0.14 f	0.71 f	1.69 e	—	0.26 f	0.93 f	2.32 e	
	16	—	—	—	—	0.57 f	—	—	—	0.19 f	1.10 f	—	—	0.33 f	1.68 f	
	24	—	—	—	—	—	—	—	—	0.09 f	—	—	—	—	0.59 f	
4" Stud	8	12	0.86 a	1.67 a	3.46 a	4.98 a	7.76 a	1.16 a	2.25 a	4.48 a	6.32 a	9.67 a	2.62 a	4.99 a	7.30 a	11.40 a
		16	0.45 b	1.26 a	3.05 a	4.55 a	7.29 a	0.72 a	1.80 a	4.02 a	5.85 a	9.17 a	2.14 a	4.53 a	6.81 a	10.90 a
		24	—	0.48 c	2.29 b	3.74 a	6.38 a	—	0.94 b	3.15 a	4.96 a	8.23 a	1.24 a	3.65 a	5.86 a	9.94 a
	9	12	0.50 b	1.27 a	2.95 a	4.37 a	6.91 a	0.77 b	1.79 a	3.84 a	5.57 a	8.66 a	2.13 a	4.42 a	6.55 a	10.29 a
		16	0.05 d	0.79 c	2.47 a	3.86 a	6.34 a	0.27 c	1.26 b	3.31 a	5.01 a	8.06 a	1.57 a	3.86 a	5.95 a	9.68 a
		24	—	—	1.60 c	2.92 c	5.29 a	—	0.29 d	2.32 c	3.98 b	6.95 a	0.53 c	2.83 b	4.83 a	8.54 a
	10	12	0.17 d	0.87 c	2.42 b	3.72 a	6.01 a	0.39 c	1.32 b	3.20 a	4.79 a	7.59 a	1.64 a	3.78 a	5.72 a	9.11 a
		16	—	0.34 d	1.90 c	3.15 b	5.37 a	—	0.74 c	2.61 b	4.16 a	6.92 a	1.01 c	3.15 a	5.03 a	8.41 a
		24	—	—	0.95 e	2.13 d	4.20 c	—	—	1.54 d	3.04 c	5.69 b	—	2.01 c	3.79 c	7.13 a
	12	12	—	0.16 e	1.45 d	2.46 c	4.24 b	—	0.48 d	2.01 c	3.27 c	5.50 a	0.71 d	2.52 c	3.99 b	6.78 a
		16	—	—	0.88 e	1.84 d	3.53 c	—	—	1.37 d	2.59 d	4.75 b	—	1.81 d	3.23 c	5.98 b
		24	—	—	—	0.77 e	2.30 e	—	—	0.26 e	1.41 e	3.43 d	—	0.58 e	1.91 e	4.58 d
	14	12	—	—	0.68 e	1.43 e	2.76 d	—	—	1.06 e	2.02 d	3.73 c	—	1.42 e	2.54 d	4.74 c
		16	—	—	0.12 f	0.84 f	2.08 e	—	—	0.44 f	1.36 e	3.00 d	—	0.73 e	1.80 e	3.95 d
		24	—	—	—	—	0.91 f	—	—	—	0.23 f	1.73 e	—	—	0.53 f	2.58 e
	16	12	—	—	0.13 f	0.71 f	1.70 e	—	—	0.40 f	1.13 e	2.44 e	—	0.63 f	1.49 e	3.22 d
		16	—	—	—	0.15 f	1.06 f	—	—	—	0.52 f	1.75 e	—	—	0.80 f	2.47 e
		24	—	—	—	—	0.03 f	—	—	—	—	0.57 f	—	—	—	1.19 f

See page 27 for clarification of code developed wind pressures prior to using this table.

Notes:

- 1 For additional general notes, see page 41.
- 2 Allowable axial loads listed in kips (1 kip = 1000 pounds).
- 3 Allowable axial loads determined in accordance with AISI S100-16 (2020) w/ S2-20 and assuming that all axial loads pass through centroid of effective section.
- 4 Listed tables are based on simple (single)-span.
- 5 Studs are assumed to be adequately braced at a maximum spacing of Lu to develop full allowable moment, Ma.
- 6 Cells marked with an "a," "b," "c," "d," "e," or "f" meet L/720, L/600, L/480, L/360, L/240, or L/120 respectively. Blank cells do not meet L/120.
- 7 For deflection calculations, lateral loads are multiplied by 0.7 per AISI S240 except for 5psf load which is considered interior wall load.
- 8 Cells marked with an "*" have h/t > 200, and thus require bearing stiffeners. Cells are left blank when h/t > 260.

Complies with AISI S100-16 (2020) w/S2-20 • IBC 2024

ALLOWABLE COMBINED AXIAL & LATERAL LOADS (Kips/Stud)

Wind = 35psf		S162 (1-5/8" Flange)					S200 (2" Flange)					S250 (2-1/2" Flange)				
Stud length (ft)	Spacing (in) o.c.	-33	-43	-54	-68	-97	-33	-43	-54	-68	-97	-43	-54	-68	-97	
		(20ga) 33ksi	(18ga) 33ksi	(16ga) 50ksi	(14ga) 50ksi	(12ga) 50ksi	(20ga) 33ksi	(18ga) 33ksi	(16ga) 50ksi	(14ga) 50ksi	(12ga) 50ksi	(18ga) 33ksi	(16ga) 50ksi	(14ga) 50ksi	(12ga) 50ksi	
6" Stud	8	12	1.57 a	2.56 a	4.81 a	6.65 a	10.58 a	1.99 a	3.38 a	6.52 a	9.02 a	14.66 a	3.70 a	6.74 a	10.08 a	17.21 a
		16	1.25 a	2.24 a	4.51 a	6.36 a	10.28 a	1.66 a	3.03 a	6.17 a	8.67 a	14.29 a	3.35 a	6.40 a	9.70 a	16.80 a
		24	0.64 a	1.63 a	3.93 a	5.77 a	9.68 a	1.02 a	2.35 a	5.48 a	7.97 a	13.56 a	2.65 a	5.73 a	8.97 a	16.01 a
	9	12	1.30 a	2.29 a	4.54 a	6.38 a	10.30 a	1.70 a	3.05 a	6.12 a	8.58 a	14.11 a	3.37 a	6.36 a	9.59 a	16.54 a
		16	0.91 a	1.90 a	4.16 a	6.00 a	9.90 a	1.29 a	2.62 a	5.67 a	8.13 a	13.64 a	2.93 a	5.93 a	9.12 a	16.02 a
		24	0.16 a	1.14 a	3.43 a	5.26 a	9.13 a	0.51 a	1.78 a	4.81 a	7.25 a	12.71 a	2.06 a	5.09 a	8.20 a	15.01 a
	10	12	1.01 a	1.99 a	4.23 a	6.06 a	9.96 a	1.38 a	2.69 a	5.66 a	8.06 a	13.45 a	3.00 a	5.92 a	9.04 a	15.75 a
		16	0.54 a	1.52 a	3.77 a	5.59 a	9.46 a	0.90 a	2.16 a	5.12 a	7.51 a	12.87 a	2.46 a	5.40 a	8.46 a	15.11 a
		24	—	0.62 a	2.88 a	4.68 a	8.50 a	—	1.17 a	4.09 a	6.45 a	11.73 a	1.44 a	4.39 a	7.35 a	13.88 a
	12	12	0.37 b	1.30 a	3.47 a	5.30 a	9.10 a	0.71 a	1.88 a	4.60 a	6.83 a	11.84 a	2.18 a	4.92 a	7.75 a	13.87 a
		16	—	0.69 b	2.84 a	4.63 a	8.37 a	0.09 c	1.20 a	3.88 a	6.09 a	11.02 a	1.47 a	4.21 a	6.97 a	12.98 a
		24	—	—	1.67 c	3.39 b	7.01 a	—	—	2.57 b	4.71 a	9.49 a	0.15 c	2.89 b	5.49 a	11.30 a
14	12	—	0.59 c	2.55 b	4.22 a	7.97 a	0.04 c	1.06 b	3.46 a	5.46 a	9.94 a	1.31 a	3.83 a	6.32 a	11.69 a	
	16	—	—	1.80 c	3.41 b	7.02 a	—	0.26 d	2.62 c	4.57 b	8.93 a	0.47 c	2.98 b	5.36 a	10.59 a	
	24	—	—	0.46 e	1.96 d	5.32 c	—	—	1.13 d	2.97 d	7.11 b	—	1.44 d	3.63 c	8.59 a	
16	12	—	—	1.65 d	3.10 c	6.31 a	—	0.29 d	2.37 c	4.11 b	7.98 a	0.49 c	2.79 c	4.91 a	9.46 a	
	16	—	—	0.85 e	2.22 d	5.26 c	—	—	1.48 d	3.14 c	6.86 b	—	1.83 d	3.84 c	8.24 a	
	24	—	—	—	0.68 e	3.44 d	—	—	—	1.45 e	4.90 d	—	0.15 e	1.96 d	6.08 c	
8" Stud	8	12	1.79 a*	2.77 a	4.90 a	6.73 a	10.76 a	2.32 a*	3.80 a	7.08 a	9.63 a	15.33 a	4.19 a	7.50 a	11.09 a	19.01 a
		16	1.55 a*	2.55 a	4.70 a	6.53 a	10.56 a	2.07 a*	3.54 a	6.82 a	9.38 a	15.08 a	3.92 a	7.24 a	10.82 a	18.72 a
		24	1.10 a*	2.10 a	4.29 a	6.13 a	10.17 a	1.58 a*	3.02 a	6.31 a	8.88 a	14.59 a	3.39 a	6.73 a	10.27 a	18.14 a
	9	12	1.60 a*	2.58 a	4.73 a	6.56 a	10.59 a	2.11 a*	3.58 a	6.85 a	9.41 a	15.11 a	3.96 a	7.25 a	10.81 a	18.67 a
		16	1.30 a*	2.30 a	4.47 a	6.30 a	10.33 a	1.80 a*	3.25 a	6.53 a	9.09 a	14.79 a	3.62 a	6.92 a	10.46 a	18.30 a
		24	0.73 a*	1.75 a	3.95 a	5.80 a	9.83 a	1.19 a*	2.60 a	5.88 a	8.45 a	14.16 a	2.94 a	6.28 a	9.77 a	17.56 a
	10	12	1.38 a*	2.38 a	4.53 a	6.36 a	10.39 a	1.88 a*	3.33 a	6.60 a	9.16 a	14.85 a	3.69 a	6.96 a	10.49 a	18.27 a
		16	1.03 a*	2.03 a	4.21 a	6.05 a	10.08 a	1.50 a*	2.93 a	6.19 a	8.76 a	14.45 a	3.27 a	6.56 a	10.06 a	17.8 a
		24	0.33 a*	1.35 a	3.57 a	5.42 a	9.45 a	0.75 a*	2.14 a	5.39 a	7.97 a	13.66 a	2.45 a	5.76 a	9.20 a	16.88 a
	12	12	0.90 a*	1.89 a	4.06 a	5.90 a	9.91 a	1.36 a*	2.76 a	5.99 a	8.55 a	14.22 a	3.07 a	6.27 a	9.70 a	17.27 a
		16	0.41 a*	1.41 a	3.60 a	5.43 a	9.45 a	0.83 a*	2.19 a	5.41 a	7.96 a	13.63 a	2.48 a	5.69 a	9.08 a	16.58 a
		24	—	0.47 a	2.70 a	4.54 a	8.54 a	—	1.10 a	4.27 a	6.82 a	12.46 a	1.35 a	4.58 a	7.86 a	15.24 a
	14	12	0.36 a*	1.34 a	3.50 a	5.32 a	9.31 a	0.76 a*	2.08 a	5.19 a	7.74 a	13.41 a	2.36 a	5.43 a	8.69 a	15.89 a
		16	—	0.70 a	2.89 a	4.70 a	8.67 a	0.08 b*	1.34 a	4.41 a	6.95 a	12.58 a	1.60 a	4.68 a	7.85 a	14.96 a
		24	—	—	1.72 b	3.51 a	7.43 a	—	—	2.96 a	5.45 a	10.98 a	0.18 b	3.25 a	6.27 a	13.19 a
	16	12	—	0.73 b	2.86 a	4.65 a	8.58 a	0.13 b*	1.33 a	4.21 a	6.61 a	12.08 a	1.59 a	4.49 a	7.48 a	14.15 a
		16	—	—	2.10 b	3.86 a	7.74 a	—	0.46 b	3.29 a	5.65 a	11.03 a	0.68 b	3.58 a	6.46 a	12.99 a
		24	—	—	0.68 d	2.39 c	6.17 a	—	—	1.59 c	3.87 b	9.06 a	—	1.89 c	4.57 a	10.83 a

See page 27 for clarification of code developed wind pressures prior to using this table.

Notes:

- 1 For additional general notes, see page 41.
- 2 Allowable axial loads listed in kips (1 kip = 1000 pounds).
- 3 Allowable axial loads determined in accordance with AISI S100-16 (2020) w/ S2-20 and assuming that all axial loads pass through centroid of effective section.
- 4 Listed tables are based on simple (single)-span.
- 5 Studs are assumed to be adequately braced at a maximum spacing of Lu to develop full allowable moment, Ma.
- 6 Cells marked with an "a," "b," "c," "d," "e," or "F" meet L/720, L/600, L/480, L/360, L/240, or L/120 respectively. Blank cells do not meet L/120.
- 7 For deflection calculations, lateral loads are multiplied by 0.7 per AISI S240 except for 5psf load which is considered interior wall load.
- 8 Cells marked with an "*" have h/t > 200, and thus require bearing stiffeners. Cells are left blank when h/t > 260.

Complies with AISI S100-16 (2020) w/S2-20 • IBC 2024

The technical content of this literature is effective 06/01/24 and supersedes all previous information.

ALLOWABLE COMBINED AXIAL & LATERAL LOADS (Kips/Stud)

Wind = 40psf		S162 (1-5/8" Flange)					S200 (2" Flange)					S250 (2-1/2" Flange)				
Stud length (ft)	Spacing (in) o.c.	-33	-43	-54	-68	-97	-33	-43	-54	-68	-97	-43	-54	-68	-97	
		(20ga) 33ksi	(18ga) 33ksi	(16ga) 50ksi	(14ga) 50ksi	(12ga) 50ksi	(20ga) 33ksi	(18ga) 33ksi	(16ga) 50ksi	(14ga) 50ksi	(12ga) 50ksi	(18ga) 33ksi	(16ga) 50ksi	(14ga) 50ksi	(12ga) 50ksi	
3-5/8" Stud	8	12	0.48 b	1.21 a	2.78 a	3.99 a	6.32 a	0.74 b	1.71 a	3.65 a	5.16 a	7.95 a	2.03 a	4.19 a	6.08 a	9.46 a
		16	0.03 d	0.74 c	2.33 b	3.52 a	5.79 a	0.25 c	1.20 b	3.14 a	4.65 a	7.39 a	1.47 a	3.64 a	5.50 a	8.90 a
		24	—	—	1.49 d	2.65 c	4.80 a	—	0.26 d	2.19 c	3.69 b	6.36 a	0.45 c	2.62 b	4.43 a	7.85 a
	9	12	0.11 d	0.78 c	2.23 b	3.32 a	5.41 a	0.32 c	1.21 b	2.97 a	4.35 a	6.88 a	1.49 a	3.49 a	5.15 a	8.29 a
		16	—	0.25 d	1.72 c	2.79 b	4.80 a	—	0.63 c	2.40 c	3.76 a	6.24 a	0.86 c	2.86 b	4.50 a	7.64 a
		24	—	—	0.81 e	1.82 d	3.69 c	—	—	1.36 d	2.70 c	5.07 b	—	1.72 d	3.30 c	6.44 a
	10	12	—	0.37 d	1.70 c	2.66 b	4.49 a	—	0.74 d	2.32 c	3.55 b	5.80 a	0.97 c	2.81 b	4.24 a	7.10 a
		16	—	—	1.16 d	2.09 d	3.84 b	—	0.12 e	1.71 d	2.93 c	5.11 a	0.28 d	2.12 c	3.53 b	6.39 a
		24	—	—	0.20 e	1.08 e	2.67 d	—	—	0.64 e	1.81 e	3.86 c	—	0.91 e	2.27 d	5.09 c
	12	12	—	—	0.79 e	1.52 e	2.86 d	—	—	1.21 e	2.16 d	3.86 c	0.06 e	1.53 d	2.64 c	4.91 b
		16	—	—	0.25 f	0.94 e	2.19 e	—	—	0.60 e	1.52 e	3.15 d	—	0.83 e	1.91 d	4.15 c
		24	—	—	—	—	1.03 f	—	—	—	0.42 f	1.89 e	—	—	0.65 e	2.82 e
14	12	—	—	0.16 f	0.71 f	1.67 e	—	—	0.43 f	1.16 e	2.42 e	—	0.61 e	1.46 e	3.22 d	
	16	—	—	—	0.16 f	1.04 f	—	—	—	0.55 f	1.74 e	—	—	0.77 f	2.49 e	
	24	—	—	—	—	—	—	—	—	0.56 f	—	—	—	—	1.23 f	
16	12	—	—	—	0.16 f	0.87 f	—	—	—	0.48 f	1.42 f	—	—	0.66 f	2.04 e	
	16	—	—	—	—	0.29 f	—	—	—	—	0.79 f	—	—	0.02 f	1.35 f	
	24	—	—	—	—	—	—	—	—	—	—	—	—	—	0.18 f	
4" Stud	8	12	0.68 a	1.49 a	3.28 a	4.80 a	7.56 a	0.97 a	2.05 a	4.28 a	6.12 a	9.45 a	2.41 a	4.79 a	7.09 a	11.19 a
		16	0.24 c	1.03 a	2.83 a	4.32 a	7.02 a	0.49 b	1.54 a	3.76 a	5.59 a	8.90 a	1.87 a	4.27 a	6.53 a	10.62 a
		24	—	0.17 c	1.98 b	3.42 a	6.01 a	—	0.60 c	2.80 b	4.60 a	7.84 a	0.87 b	3.29 a	5.47 a	9.54 a
	9	12	0.31 c	1.06 b	2.74 a	4.14 a	6.67 a	0.55 b	1.55 a	3.61 a	5.33 a	8.40 a	1.89 a	4.18 a	6.29 a	10.02 a
		16	—	0.53 c	2.21 b	3.58 a	6.03 a	—	0.97 b	3.01 a	4.71 a	7.74 a	1.26 b	3.56 a	5.62 a	9.34 a
		24	—	—	1.25 d	2.55 c	4.86 b	—	—	1.93 c	3.57 b	6.50 a	0.12 d	2.42 c	4.38 b	8.07 a
	10	12	—	0.64 c	2.19 b	3.47 a	5.73 a	0.15 d	1.07 c	2.94 a	4.51 a	7.30 a	1.36 b	3.50 a	5.42 a	8.81 a
		16	—	0.06 d	1.61 d	2.84 c	5.02 a	—	0.42 d	2.29 c	3.83 b	6.55 a	0.67 c	2.81 b	4.66 a	8.03 a
		24	—	—	0.58 e	1.73 d	3.75 c	—	—	1.13 d	2.59 d	5.20 b	—	1.56 d	3.30 c	6.62 b
	12	12	—	—	1.20 e	2.18 d	3.93 c	—	0.20 e	1.73 d	2.97 c	5.17 b	0.40 d	2.21 c	3.66 b	6.43 a
		16	—	—	0.58 e	1.52 e	3.16 d	—	—	1.03 e	2.23 d	4.35 c	—	1.44 d	2.83 d	5.56 b
		24	—	—	—	0.36 f	1.83 e	—	—	—	0.95 e	2.92 e	—	0.10 e	1.40 e	4.03 d
	14	12	—	—	0.43 f	1.17 e	2.46 d	—	—	0.79 e	1.73 e	3.41 d	—	1.11 e	2.22 d	4.39 c
		16	—	—	—	0.53 f	1.72 e	—	—	0.12 f	1.02 e	2.61 e	—	0.36 f	1.42 e	3.54 d
		24	—	—	—	—	0.46 f	—	—	—	—	1.24 f	—	—	0.05 f	2.06 e
	16	12	—	—	—	0.46 f	1.42 e	—	—	0.14 f	0.86 f	2.13 e	—	0.34 f	1.19 e	2.89 e
		16	—	—	—	—	0.73 f	—	—	—	0.20 f	1.39 f	—	—	0.44 f	2.08 e
		24	—	—	—	—	—	—	—	—	—	0.13 f	—	—	—	0.70 f

See page 27 for clarification of code developed wind pressures prior to using this table.

Notes:

- 1 For additional general notes, see page 41.
- 2 Allowable axial loads listed in kips (1 kip = 1000 pounds).
- 3 Allowable axial loads determined in accordance with AISI S100-16 (2020) w/ S2-20 and assuming that all axial loads pass through centroid of effective section.
- 4 Listed tables are based on simple (single)-span.
- 5 Studs are assumed to be adequately braced at a maximum spacing of L_u to develop full allowable moment, M_a .
- 6 Cells marked with an "a," "b," "c," "d," "e," or "f" meet L/720, L/600, L/480, L/360, L/240, or L/120 respectively. Blank cells do not meet L/120.
- 7 For deflection calculations, lateral loads are multiplied by 0.7 per AISI S240 except for 5psf load which is considered interior wall load.
- 8 Cells marked with an "*" have $h/t > 200$, and thus require bearing stiffeners. Cells are left blank when $h/t > 260$.

Complies with AISI S100-16 (2020) w/S2-20 • IBC 2024

ALLOWABLE COMBINED AXIAL & LATERAL LOADS

(Kips/Stud)

Wind = 40psf		S162 (1-5/8" Flange)					S200 (2" Flange)					S250 (2-1/2" Flange)				
Stud length (ft)	Spacing (in) o.c.	-33	-43	-54	-68	-97	-33	-43	-54	-68	-97	-43	-54	-68	-97	
		(20ga) 33ksi	(18ga) 33ksi	(16ga) 50ksi	(14ga) 50ksi	(12ga) 50ksi	(20ga) 33ksi	(18ga) 33ksi	(16ga) 50ksi	(14ga) 50ksi	(12ga) 50ksi	(18ga) 33ksi	(16ga) 50ksi	(14ga) 50ksi	(12ga) 50ksi	
6" Stud	8	12	1.43 a	2.42 a	4.68 a	6.52 a	10.45 a	1.84 a	3.23 a	6.37 a	8.87 a	14.50 a	3.55 a	6.59 a	9.92 a	17.03 a
		16	1.07 a	2.07 a	4.34 a	6.19 a	10.11 a	1.47 a	2.83 a	5.97 a	8.47 a	14.08 a	3.15 a	6.21 a	9.49 a	16.57 a
		24	0.38 a	1.38 a	3.68 a	5.52 a	9.42 a	0.75 a	2.06 a	5.19 a	7.68 a	13.25 a	2.35 a	5.44 a	8.66 a	15.67 a
	9	12	1.13 a	2.12 a	4.38 a	6.22 a	10.13 a	1.52 a	2.86 a	5.93 a	8.38 a	13.91 a	3.18 a	6.17 a	9.39 a	16.31 a
		16	0.69 a	1.68 a	3.95 a	5.79 a	9.68 a	1.07 a	2.37 a	5.42 a	7.87 a	13.37 a	2.68 a	5.68 a	8.86 a	15.73 a
		24	—	0.83 a	3.12 a	4.95 a	8.80 a	0.19 a	1.43 a	4.45 a	6.88 a	12.32 a	1.70 a	4.74 a	7.82 a	14.58 a
	10	12	0.81 a	1.79 a	4.03 a	5.86 a	9.74 a	1.17 a	2.46 a	5.42 a	7.82 a	13.20 a	2.77 a	5.69 a	8.79 a	15.48 a
		16	0.29 a	1.26 a	3.51 a	5.33 a	9.18 a	0.63 a	1.87 a	4.82 a	7.20 a	12.54 a	2.16 a	5.10 a	8.14 a	14.75 a
		24	—	0.25 b	2.51 a	4.31 a	8.10 a	—	0.77 a	3.67 a	6.01 a	11.26 a	1.01 a	3.97 a	6.89 a	13.36 a
	12	12	0.12 c	1.03 a	3.20 a	5.01 a	8.78 a	0.44 b	1.59 a	4.29 a	6.51 a	11.49 a	1.87 a	4.61 a	7.41 a	13.48 a
		16	—	0.35 c	2.49 b	4.27 a	7.97 a	—	0.83 b	3.50 a	5.68 a	10.57 a	1.08 a	3.82 a	6.53 a	12.48 a
		24	—	—	1.20 d	2.89 c	6.46 a	—	—	2.04 c	4.15 b	8.86 a	—	2.36 b	4.90 a	10.62 a
14	12	—	0.27 d	2.22 c	3.86 a	7.55 a	—	0.71 c	3.09 b	5.07 a	9.50 a	0.94 b	3.46 a	5.90 a	11.21 a	
	16	—	—	1.40 d	2.98 c	6.51 a	—	—	2.18 c	4.09 b	8.39 a	0.01 d	2.52 c	4.85 a	10.00 a	
	24	—	—	—	1.39 d	4.64 c	—	—	0.55 e	2.34 d	6.39 c	—	0.83 d	2.95 c	7.80 b	
16	12	—	—	1.30 d	2.71 c	5.84 b	—	—	1.98 d	3.68 c	7.49 a	0.08 d	2.36 c	4.43 b	8.92 a	
	16	—	—	0.42 e	1.75 d	4.71 c	—	—	1.01 e	2.63 d	6.27 c	—	1.32 d	3.27 c	7.59 b	
	24	—	—	—	0.08 e	2.73 e	—	—	—	0.79 e	4.14 d	—	—	1.23 e	5.24 d	
8" Stud	8	12	1.69 a*	2.67 a	4.81 a	6.64 a	10.67 a	2.21 a*	3.68 a	6.97 a	9.52 a	15.22 a	4.08 a	7.39 a	10.97 a	18.88 a
		16	1.42 a*	2.42 a	4.58 a	6.41 a	10.45 a	1.93 a*	3.39 a	6.67 a	9.23 a	14.94 a	3.77 a	7.10 a	10.66 a	18.55 a
		24	0.90 a*	1.92 a	4.12 a	5.96 a	10.00 a	1.37 a*	2.80 a	6.09 a	8.67 a	14.38 a	3.16 a	6.52 a	10.04 a	17.89 a
	9	12	1.47 a*	2.46 a	4.62 a	6.45 a	10.48 a	1.98 a*	3.44 a	6.71 a	9.27 a	14.97 a	3.81 a	7.11 a	10.66 a	18.51 a
		16	1.14 a*	2.14 a	4.32 a	6.16 a	10.19 a	1.62 a*	3.06 a	6.34 a	8.90 a	14.61 a	3.42 a	6.74 a	10.26 a	18.08 a
		24	0.49 a*	1.51 a	3.73 a	5.58 a	9.62 a	0.93 a*	2.33 a	5.60 a	8.18 a	13.89 a	2.66 a	6.00 a	9.48 a	17.24 a
	10	12	1.23 a*	2.23 a	4.39 a	6.23 a	10.26 a	1.72 a*	3.16 a	6.43 a	8.99 a	14.68 a	3.51 a	6.79 a	10.30 a	18.07 a
		16	0.83 a*	1.83 a	4.02 a	5.87 a	9.90 a	1.29 a*	2.70 a	5.96 a	8.53 a	14.23 a	3.04 a	6.33 a	9.81 a	17.54 a
		24	0.04 a*	1.06 a	3.30 a	5.15 a	9.19 a	0.44 a*	1.80 a	5.06 a	7.63 a	13.32 a	2.11 a	5.42 a	8.84 a	16.49 a
	12	12	0.69 a*	1.68 a	3.86 a	5.70 a	9.71 a	1.13 a*	2.52 a	5.74 a	8.29 a	13.97 a	2.82 a	6.02 a	9.43 a	16.97 a
		16	0.13 a*	1.13 a	3.34 a	5.18 a	9.19 a	0.53 a*	1.87 a	5.08 a	7.63 a	13.29 a	2.16 a	5.37 a	8.72 a	16.20 a
		24	—	0.08 a	2.33 a	4.16 a	8.16 a	—	0.64 a	3.80 a	6.35 a	11.97 a	0.89 a	4.11 a	7.35 a	14.68 a
	14	12	0.08 b*	1.06 a	3.24 a	5.05 a	9.03 a	0.46 a*	1.76 a	4.85 a	7.39 a	13.05 a	2.03 a	5.11 a	8.33 a	15.49 a
		16	—	0.35 b	2.54 a	4.35 a	8.31 a	—	0.94 a	3.99 a	6.51 a	12.11 a	1.18 a	4.26 a	7.39 a	14.45 a
		24	—	—	1.24 c	3.02 a	6.92 a	—	—	2.37 b	4.83 a	10.33 a	—	2.67 a	5.62 a	12.45 a
	16	12	—	0.40 b	2.53 a	4.31 a	8.21 a	—	0.95 a	3.81 a	6.19 a	11.62 a	1.19 a	4.10 a	7.04 a	13.64 a
		16	—	—	1.68 c	3.43 a	7.28 a	—	—	2.78 b	5.12 a	10.45 a	0.19 b	3.08 a	5.90 a	12.35 a
		24	—	—	0.12 d	1.80 c	5.53 b	—	—	0.92 d	3.16 c	8.27 a	—	1.21 c	3.81 b	9.95 a

See page 27 for clarification of code developed wind pressures prior to using this table.

Notes:

- For additional general notes, see page 41.
- Allowable axial loads listed in kips (1 kip = 1000 pounds).
- Allowable axial loads determined in accordance with AISI S100-16 (2020) w/ S2-20 and assuming that all axial loads pass through centroid of effective section.
- Listed tables are based on simple (single)-span.
- Studs are assumed to be adequately braced at a maximum spacing of L_u to develop full allowable moment, M_n .
- Cells marked with an "a," "b," "c," "d," "e," or "F" meet L/720, L/600, L/480, L/360, L/240, or L/120 respectively. Blank cells do not meet L/120.
- For deflection calculations, lateral loads are multiplied by 0.7 per AISI S240 except for 5psf load which is considered interior wall load.
- Cells marked with an "*" have $h/t > 200$, and thus require bearing stiffeners. Cells are left blank when $h/t > 260$.

Complies with AISI S100-16 (2020) w/S2-20 • IBC 2024

The technical content of this literature is effective 06/01/24 and supersedes all previous information.

Allowable Unbraced Axial Loads

General Notes:

- 1 Allowable axial loads listed in kips (1 kip=1000 pounds).
- 2 Allowable axial loads do not include a 1/3 allowable stress increase.
- 3 Allowable axial loads are based on punched webs. Punchout is a 4" long by 1-1/2" high oval.
- 4 Allowable axial loads are based on concentric axial loading condition only.
- 5 The lengths indicated are for unbraced lengths. The addition of intermediate bracing may increase the allowable axial loads.
- 6 Listed axial loads marked with " * " indicates the $KL/r > 300$.
- 7 Listed axial loads marked with " ws " indicates that $h/t > 200$. This indicates that web stiffeners are required to prevent web crippling at points of concentrated loads.
- 8 Listed capacities are calculated per AISI S100-16 (2020) w/S2-20.

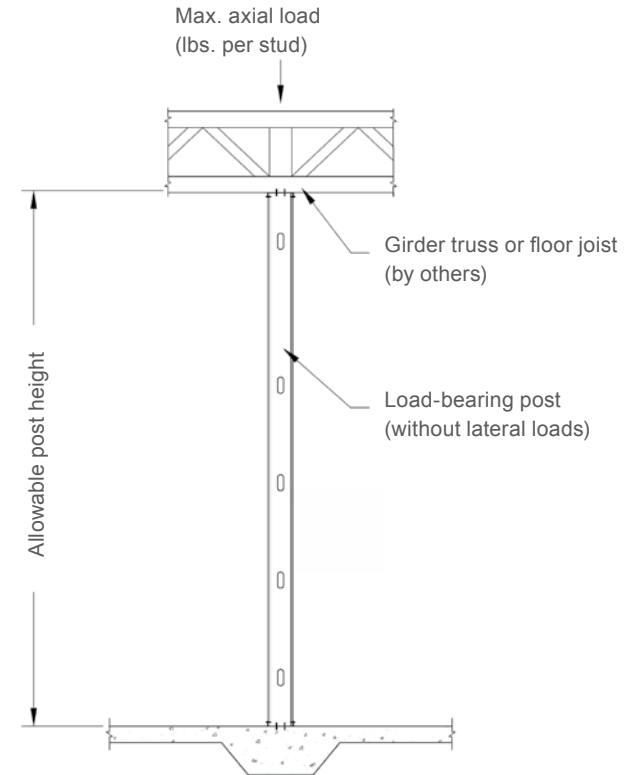
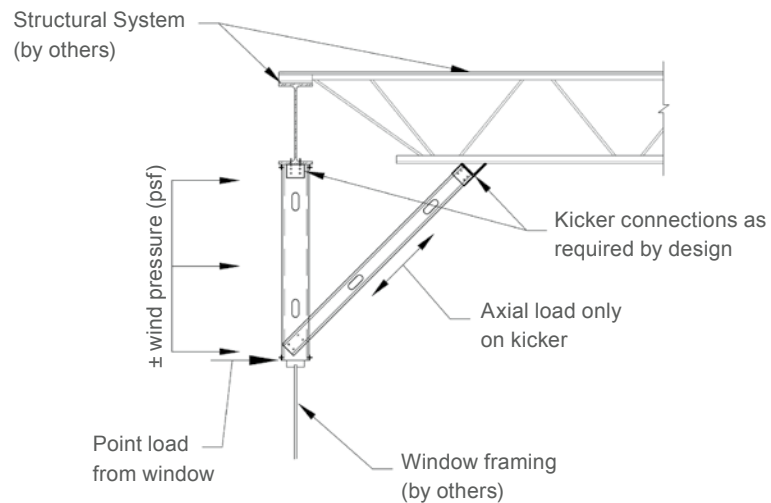

Complies with AISI S100-16 (2020) w/S2-20 • IBC 2024

ALLOWABLE UNBRACED AXIAL LOADS

Based on length (Kips)

Member	Fy (ksi)	Unbraced Length (ft)																							
		1	1.5	2	2.5	3	3.5	4	5	6	7	8	9	10	11	12	13	14	15	16	17	18	19	20	
3-5/8" Stud	362S137-33	33	2.66	2.59	2.49	2.38	2.21	2.02	1.82	1.44	1.09	0.86	0.70	0.56	0.46	0.38	0.32	0.27 *	0.23 *	0.2 *	0.18 *	0.16 *	0.14 *	0.13 *	0.11 *
	362S137-43	33	3.81	3.67	3.49	3.27	3.03	2.78	2.52	2.02	1.57	1.18	0.90	0.71	0.58	0.48	0.40	0.34 *	0.3 *	0.26 *	0.23 *	0.2 *	0.18 *	0.16 *	0.14 *
	362S137-54	50	6.88	6.62	6.22	5.66	5.06	4.46	3.89	2.79	1.93	1.42	1.09	0.86	0.70	0.58	0.48	0.41 *	0.36 *	0.31 *	0.27 *	0.24 *	0.21 *	0.19 *	0.17 *
	362S137-68	50	9.28	8.78	8.14	7.43	6.67	5.83	4.93	3.31	2.30	1.69	1.29	1.02	0.83	0.68	0.57	0.49 *	0.42 *	0.37 *	0.32 *	0.29 *	0.26 *	0.23 *	0.21 *
	362S137-97	50	13.07	12.32	11.32	10.14	8.87	7.57	6.31	4.15	2.88	2.12	1.62	1.28	1.04	0.86	0.72 *	0.61 *	0.53 *	0.46 *	0.4 *	0.36 *	0.32 *	0.29 *	0.26 *
	362S162-33	33	3.12	3.05	2.96	2.84	2.69	2.50	2.29	1.87	1.47	1.14	0.91	0.75	0.63	0.53	0.46	0.41	0.37	0.33	0.3 *	0.27 *	0.24 *	0.22 *	0.2 *
	362S162-43	33	4.43	4.30	4.12	3.91	3.67	3.40	3.13	2.58	2.06	1.60	1.28	1.05	0.89	0.77	0.68	0.59	0.51	0.44	0.39 *	0.35 *	0.31 *	0.28 *	0.25 *
	362S162-54	50	7.99	7.74	7.44	6.87	6.24	5.60	4.96	3.76	2.75	2.13	1.73	1.45	1.21	1.00	0.84	0.72	0.62	0.54	0.47 *	0.42 *	0.37 *	0.34 *	0.3 *
	362S162-68	50	10.79	10.31	9.68	8.95	8.16	7.31	6.46	4.92	3.70	2.94	2.28	1.80	1.46	1.20	1.01	0.86	0.74	0.65 *	0.57 *	0.5 *	0.45 *	0.4 *	0.36 *
	362S162-97	50	15.24	14.50	13.58	12.55	11.48	10.43	9.43	7.30	5.21	3.83	2.93	2.32	1.88	1.55	1.30	1.11	0.96	0.83 *	0.73 *	0.65 *	0.58 *	0.52 *	0.47 *
	362S200-33	33	3.41	3.35	3.26	3.15	3.02	2.88	2.72	2.35	1.96	1.53	1.21	0.99	0.82	0.69	0.59	0.52	0.46	0.41	0.37	0.33	0.30	0.28	0.26 *
	362S200-43	33	5.12	5.03	4.88	4.70	4.47	4.20	3.90	3.28	2.68	2.12	1.66	1.35	1.13	0.96	0.83	0.73	0.66	0.59	0.54	0.50	0.46	0.43	0.4 *
	362S200-54	50	8.79	8.62	8.41	8.12	7.70	7.02	6.30	4.90	3.62	2.75	2.18	1.79	1.51	1.31	1.15	1.03	0.93	0.85	0.78	0.72	0.68	0.62	0.56 *
	362S200-68	50	12.43	12.11	11.64	10.87	10.02	9.12	8.15	6.30	4.72	3.64	2.94	2.46	2.11	1.85	1.65	1.50	1.37	1.21	1.06	0.94	0.84	0.75 *	0.68 *
	362S200-97	50	18.07	17.33	16.37	15.26	14.06	12.82	11.61	9.35	7.44	5.96	4.98	4.30	3.58	2.96	2.49	2.12	1.83	1.59	1.40	1.24	1.11	0.99 *	0.9 *
	362S250-43	33	5.25	5.16	5.04	4.89	4.71	4.51	4.29	3.80	3.15	2.49	1.95	1.57	1.30	1.09	0.94	0.82	0.73	0.65	0.59	0.53	0.49	0.45	0.42
	362S250-54	50	9.00	8.77	8.46	8.08	7.63	7.13	6.64	5.67	4.25	3.20	2.51	2.04	1.70	1.45	1.26	1.11	0.99	0.90	0.82	0.75	0.70	0.65	0.61
	362S250-68	50	12.44	12.16	11.78	11.32	10.80	10.00	9.13	7.36	5.46	4.15	3.30	2.72	2.30	1.99	1.75	1.57	1.42	1.30	1.19	1.11	1.04	0.98	0.92
	362S250-97	50	19.64	18.98	18.14	17.19	16.24	14.88	13.43	10.69	8.30	6.50	5.32	4.50	3.91	3.47	3.12	2.84	2.62	2.43	2.27	2.13	1.96	1.76	1.59
	4" Stud	400S137-33	33	2.69	2.62	2.53	2.42	2.27	2.09	1.90	1.52	1.18	0.91	0.72	0.58	0.48	0.39	0.33	0.28 *	0.24 *	0.21 *	0.19 *	0.17 *	0.15 *	0.13 *
400S137-43		33	3.86	3.73	3.56	3.36	3.13	2.88	2.63	2.13	1.62	1.23	0.95	0.75	0.61	0.50	0.42	0.36 *	0.31 *	0.27 *	0.24 *	0.21 *	0.19 *	0.17 *	0.15 *
400S137-54		50	6.99	6.74	6.39	5.85	5.28	4.68	4.04	2.85	2.03	1.49	1.14	0.90	0.73	0.60	0.51	0.43 *	0.37 *	0.32 *	0.28 *	0.25 *	0.23 *	0.2 *	0.18 *
400S137-68		50	9.51	9.04	8.44	7.70	6.89	6.04	5.18	3.47	2.41	1.77	1.35	1.07	0.87	0.72	0.6 *	0.51 *	0.44 *	0.39 *	0.34 *	0.3 *	0.27 *	0.24 *	0.22 *
400S137-97		50	14.09	13.24	12.13	10.84	9.45	8.03	6.66	4.35	3.02	2.22	1.70	1.34	1.09	0.90	0.76 *	0.64 *	0.56 *	0.48 *	0.42 *	0.38 *	0.34 *	0.3 *	0.27 *
400S162-33		33	3.15	3.08	3.00	2.89	2.75	2.58	2.39	1.99	1.60	1.25	1.01	0.83	0.70	0.61	0.53	0.46	0.41	0.36	0.32 *	0.28 *	0.25 *	0.23 *	0.21 *
400S162-43		33	4.49	4.37	4.20	4.01	3.78	3.54	3.28	2.75	2.24	1.78	1.45	1.20	1.01	0.86	0.73	0.62	0.53	0.47	0.41 *	0.36 *	0.32 *	0.29 *	0.26 *
400S162-54		50	8.10	7.88	7.59	7.10	6.51	5.90	5.28	4.10	3.10	2.43	1.96	1.57	1.27	1.05	0.88	0.75	0.65	0.56 *	0.5 *	0.44 *	0.39 *	0.35 *	0.32 *
400S162-68		50	11.03	10.58	10.00	9.32	8.58	7.80	7.03	5.56	4.21	3.11	2.38	1.88	1.53	1.26	1.06	0.90	0.78	0.68 *	0.6 *	0.53 *	0.47 *	0.42 *	0.38 *
400S162-97		50	16.31	15.59	14.68	13.64	12.55	11.45	10.21	7.69	5.47	4.02	3.07	2.43	1.97	1.63	1.37	1.16	1.00	0.87 *	0.77 *	0.68 *	0.61 *	0.55 *	0.49 *
400S200-33		33	3.44	3.38	3.30	3.20	3.09	2.96	2.81	2.48	2.12	1.71	1.36	1.11	0.93	0.80	0.69	0.60	0.53	0.47	0.42	0.38	0.35	0.32	0.3 *
400S200-43		33	5.17	5.09	4.96	4.80	4.60	4.35	4.08	3.50	2.92	2.38	1.91	1.57	1.31	1.11	0.96	0.84	0.75	0.68	0.62	0.56	0.52	0.48	0.45 *
400S200-54		50	8.89	8.75	8.55	8.32	7.93	7.40	6.72	5.37	4.13	3.20	2.53	2.07	1.75	1.50	1.32	1.17	1.06	0.96	0.88	0.81	0.72	0.65 *	0.59 *
400S200-68		50	12.66	12.37	12.00	11.30	10.52	9.68	8.82	7.12	5.50	4.22	3.39	2.83	2.42	2.11	1.88	1.69	1.45	1.27	1.11	0.99	0.88	0.79 *	0.71 *
400S200-97		50	19.17	18.46	17.55	16.47	15.29	14.07	12.84	10.51	8.49	6.83	5.68	4.63	3.75	3.10	2.61	2.22	1.91	1.67	1.47	1.30	1.16	1.04 *	0.94 *
400S250-43		33	5.30	5.22	5.12	4.99	4.83	4.66	4.46	4.01	3.47	2.84	2.27	1.85	1.54	1.29	1.11	0.97	0.85	0.76	0.69	0.62	0.57	0.53	0.49
400S250-54		50	9.12	8.92	8.65	8.31	7.91	7.47	6.98	6.15	4.94	3.78	2.98	2.41	2.01	1.71	1.48	1.30	1.16	1.04	0.95	0.87	0.80	0.75	0.70
400S250-68	50	12.67	12.42	12.09	11.69	11.22	10.59	9.82	8.37	6.49	4.92	3.90	3.20	2.69	2.32	2.03	1.81	1.63	1.49	1.37	1.27	1.19	1.11	1.05	
400S250-97	50	20.74	20.13	19.33	18.41	17.45	16.34	14.92	12.15	9.68	7.61	6.20	5.22	4.51	3.98	3.58	3.25	2.99	2.77	2.59	2.30	2.05	1.84	1.66	

Notes:

- For additional general notes, see page 56.
- Listed axial loads marked with "*" indicate the KL/r > 300.
- Listed axial loads marked with "ws" indicate that h/t > 200.
This indicates that web stiffeners are required to prevent web crippling at points of concentrated loads.
- Listed capacities are calculated per AISI S100-16 (2020) w/S2-20.

Complies with AISI S100-16 (2020) w/S2-20 • IBC 2024

ALLOWABLE UNBRACED AXIAL LOADS

Based on length (Kips)

Member	Fy (ksi)	Unbraced Length (ft)																							
		1	1.5	2	2.5	3	3.5	4	5	6	7	8	9	10	11	12	13	14	15	16	17	18	19	20	
5-1/2" Stud	550S137-33	33	2.73	2.66	2.56	2.46	2.30	2.11	1.91	1.50	1.13	0.87	0.70	0.57	0.48	0.41	0.35 *	0.31 *	0.27 *	0.24 *	0.21 *	0.19 *	0.17 *	0.15 *	0.14 *
	550S137-43	33	3.95	3.82	3.64	3.43	3.19	2.92	2.64	2.09	1.57	1.21	0.97	0.80	0.67	0.57	0.48 *	0.41 *	0.35 *	0.31 *	0.27 *	0.24 *	0.21 *	0.19 *	0.17 *
	550S137-54	50	7.17	6.91	6.52	5.93	5.29	4.63	3.97	2.79	2.06	1.59	1.27	1.03	0.84	0.69	0.58 *	0.49 *	0.43 *	0.37 *	0.33 *	0.29 *	0.26 *	0.23 *	0.21 *
	550S137-68	50	9.87	9.36	8.68	7.88	7.01	6.10	5.20	3.64	2.67	2.03	1.55	1.23	0.99	0.82	0.69 *	0.59 *	0.51 *	0.44 *	0.39 *	0.34 *	0.31 *	0.28 *	0.25 *
	550S137-97	50	15.46	14.59	13.45	12.10	10.64	9.13	7.65	5.02	3.48	2.56	1.96	1.55	1.25	1.04 *	0.87 *	0.74 *	0.64 *	0.56 *	0.49 *	0.43 *	0.39 *	0.35 *	0.31 *
	550S162-33	33	3.20	3.15	3.07	2.99	2.87	2.74	2.57	2.20	1.81	1.45	1.15	0.94	0.78	0.67	0.58	0.50	0.44	0.39 *	0.35 *	0.32 *	0.29 *	0.26 *	0.23 *
	550S162-43	33	4.60	4.50	4.36	4.19	3.99	3.77	3.53	3.02	2.50	1.99	1.59	1.30	1.09	0.92	0.80	0.69	0.61	0.53 *	0.47 *	0.41 *	0.37 *	0.33 *	0.3 *
	550S162-54	50	8.32	8.13	7.87	7.50	6.96	6.38	5.76	4.53	3.39	2.61	2.08	1.70	1.42	1.20	1.01	0.86	0.74	0.65 *	0.57 *	0.5 *	0.45 *	0.4 *	0.36 *
	550S162-68	50	11.47	11.08	10.56	9.92	9.20	8.41	7.59	5.93	4.43	3.40	2.70	2.16	1.75	1.45	1.22	1.04	0.89	0.78 *	0.68 *	0.61 *	0.54 *	0.49 *	0.44 *
	550S162-97	50	17.79	17.15	16.29	15.26	14.07	12.80	11.46	8.78	6.30	4.63	3.54	2.80	2.27	1.87	1.57	1.34	1.16 *	1.01 *	0.89 *	0.78 *	0.7 *	0.63 *	0.57 *
	550S200-33	33	3.49	3.45	3.39	3.32	3.23	3.13	3.02	2.76	2.46	2.15	1.80	1.48	1.24	1.06	0.92	0.81	0.72	0.65	0.59	0.54	0.49	0.45 *	0.41 *
	550S200-43	33	5.28	5.22	5.13	5.01	4.86	4.69	4.48	4.00	3.50	3.00	2.53	2.09	1.77	1.52	1.33	1.18	1.05	0.94	0.84	0.75	0.68	0.61 *	0.55 *
	550S200-54	50	9.11	9.00	8.85	8.67	8.46	8.12	7.67	6.50	5.34	4.27	3.45	2.87	2.45	2.09	1.80	1.56	1.37	1.20	1.05	0.93	0.83	0.75 *	0.67 *
	550S200-68	50	13.11	12.90	12.62	12.20	11.58	10.90	10.18	8.68	7.22	5.87	4.74	3.86	3.21	2.70	2.27	1.94	1.67	1.45	1.28	1.13	1.01	0.91 *	0.82 *
	550S200-97	50	20.73	20.24	19.57	18.77	17.85	16.86	15.82	13.54	11.12	8.78	6.75	5.33	4.32	3.57	3.00	2.56	2.20	1.92	1.69	1.49	1.33 *	1.2 *	1.08 *
	550S250-43	33	5.41	5.36	5.29	5.20	5.09	4.96	4.82	4.50	4.14	3.72	3.19	2.69	2.25	1.92	1.67	1.47	1.30	1.17	1.06	0.97	0.89	0.82	0.76
	550S250-54	50	9.36	9.22	9.03	8.80	8.52	8.20	7.85	7.06	6.41	5.46	4.39	3.61	3.05	2.62	2.29	2.02	1.81	1.63	1.49	1.35	1.24	1.14	1.06
550S250-68	50	13.13	12.96	12.73	12.44	12.11	11.73	11.31	10.04	8.87	7.35	5.97	4.96	4.21	3.65	3.21	2.84	2.53	2.28	2.08	1.91	1.76	1.58	1.43	
550S250-97	50	22.32	21.92	21.39	20.75	20.04	19.28	18.54	16.26	13.97	11.82	9.86	8.20	6.98	6.07	5.30	4.52	3.89	3.39	2.98	2.64	2.36	2.11	1.91	
6" Stud	600S137-33	33	2.73	2.66	2.56	2.45	2.29	2.09	1.89	1.48	1.11	0.86	0.69	0.57	0.48	0.41	0.35 *	0.31 *	0.27 *	0.24 *	0.22 *	0.2 *	0.17 *	0.16 *	0.14 *
	600S137-43	33	3.96	3.83	3.65	3.43	3.18	2.91	2.62	2.05	1.54	1.20	0.96	0.79	0.67	0.57	0.49 *	0.42 *	0.37 *	0.32 *	0.28 *	0.25 *	0.22 *	0.2 *	0.18 *
	600S137-54	50	7.20	6.93	6.51	5.91	5.26	4.58	3.91	2.75	2.03	1.58	1.27	1.04	0.86	0.71	0.6 *	0.51 *	0.44 *	0.38 *	0.34 *	0.3 *	0.27 *	0.24 *	0.22 *
	600S137-68	50	9.92	9.39	8.69	7.87	6.98	6.06	5.15	3.60	2.66	2.06	1.61	1.27	1.03	0.85	0.71 *	0.61 *	0.53 *	0.46 *	0.4 *	0.36 *	0.32 *	0.29 *	0.26 *
	600S137-97	50	15.65	14.74	13.56	12.19	10.69	9.15	7.64	5.19	3.61	2.65	2.03	1.60	1.30	1.07 *	0.9 *	0.77 *	0.66 *	0.58 *	0.51 *	0.45 *	0.4 *	0.36 *	0.32 *
	600S162-33	33	3.20	3.15	3.08	2.99	2.87	2.73	2.56	2.18	1.79	1.42	1.13	0.93	0.77	0.66	0.57	0.50	0.44	0.39 *	0.35 *	0.32 *	0.29 *	0.26 *	0.24 *
	600S162-43	33	4.61	4.51	4.37	4.19	3.99	3.77	3.52	3.00	2.47	1.97	1.57	1.29	1.08	0.92	0.79	0.69	0.61	0.54 *	0.48 *	0.43 *	0.38 *	0.34 *	0.31 *
	600S162-54	50	8.35	8.15	7.89	7.49	6.95	6.35	5.73	4.48	3.35	2.58	2.06	1.69	1.42	1.20	1.04	0.89	0.77	0.67 *	0.59 *	0.52 *	0.47 *	0.42 *	0.38 *
	600S162-68	50	11.53	11.13	10.59	9.94	9.20	8.40	7.56	5.89	4.39	3.39	2.70	2.21	1.81	1.50	1.26	1.07	0.93	0.81 *	0.71 *	0.63 *	0.56 *	0.5 *	0.45 *
	600S162-97	50	17.99	17.33	16.45	15.38	14.18	12.87	11.51	8.80	6.47	4.79	3.67	2.90	2.35	1.94	1.63	1.39	1.2 *	1.04 *	0.92 *	0.81 *	0.73 *	0.65 *	0.59 *
	600S200-33	33	3.50	3.46	3.41	3.34	3.25	3.16	3.05	2.81	2.53	2.23	1.90	1.57	1.31	1.12	0.97	0.86	0.76	0.68	0.60	0.54	0.49	0.45 *	0.41 *
	600S200-43	33	5.30	5.24	5.16	5.04	4.90	4.75	4.55	4.09	3.61	3.12	2.65	2.21	1.87	1.59	1.37	1.20	1.05	0.94	0.84	0.75	0.68	0.62 *	0.57 *
	600S200-54	50	9.15	9.05	8.91	8.74	8.54	8.22	7.84	6.71	5.57	4.51	3.61	2.95	2.46	2.09	1.80	1.57	1.38	1.22	1.09	0.96	0.86	0.77 *	0.7 *
	600S200-68	50	13.19	12.99	12.72	12.35	11.76	11.11	10.42	8.96	7.44	5.95	4.73	3.86	3.22	2.73	2.34	2.01	1.73	1.51	1.32	1.17	1.05	0.94 *	0.85 *
	600S200-97	50	20.97	20.50	19.87	19.08	18.16	17.13	16.02	13.63	11.18	8.82	6.98	5.53	4.48	3.70	3.11	2.65	2.28	1.99	1.75	1.55	1.38 *	1.24 *	1.12 *
	600S250-43	33	5.43	5.38	5.32	5.23	5.14	5.02	4.89	4.59	4.25	3.88	3.39	2.89	2.44	2.08	1.80	1.59	1.41	1.27	1.15	1.05	0.96	0.89	0.82
	600S250-54	50	9.40	9.27	9.10	8.89	8.63	8.33	8.00	7.27	6.62	5.82	4.75	3.91	3.30	2.83	2.47	2.19	1.96	1.77	1.61	1.48	1.36	1.27	1.18
600S250-68	50	13.21	13.05	12.84	12.58	12.27	11.91	11.53	10.38	9.22	7.86	6.46	5.36	4.55	3.94	3.47	3.09	2.78	2.53	2.30	2.05	1.83	1.64	1.48	
600S250-97	50	22.56	22.19	21.70	21.11	20.44	19.72	19.00	16.96	14.74	12.62	10.67	9.00	7.76	6.54	5.49	4.68	4.04	3.52	3.09	2.74	2.44	2.19	1.98	
600S300-54	50	9.56	9.45	9.30	9.11	8.88	8.62	8.33	7.67	6.93	6.14	5.40	4.68	3.98	3.39	2.94	2.59	2.30	2.06	1.87	1.70	1.56	1.44	1.34	
600S300-68	50	13.52	13.36	13.14	12.86	12.52	12.13	11.71	10.76	9.85	8.83	7.56	6.41	5.40	4.64	4.05	3.58	3.20	2.88	2.61	2.38	2.18	2.01	1.86	
600S300-97	50	23.94	23.66	23.29	22.82	22.26	21.47	20.51	18.45	16.38	14.49	12.46	10.44	8.90	7.67	6.69	5.93	5.32	4.82	4.42	4.08	3.80	3.49	3.15	

Notes:

- 1 For additional general notes, see page 56.
- 2 Listed axial loads marked with " * " indicate the KL/r > 300.
- 3 Listed axial loads marked with "ws" indicate that h/t > 200. This indicates that web stiffeners are required to prevent web crippling at points of concentrated loads.
- 4 Listed capacities are calculated per AISI S100-16 (2020) w/S2-20.

Complies with AISI S100-16 (2020) w/S2-20 • IBC 2024

ALLOWABLE UNBRACED AXIAL LOADS

Based on length (Kips)

Member	Fy (ksi)	Unbraced Length (ft)																							
		1	1.5	2	2.5	3	3.5	4	5	6	7	8	9	10	11	12	13	14	15	16	17	18	19	20	
8" Stud	800S137-33	33	2.74 ws	2.66 ws	2.55 ws	2.43 ws	2.23 ws	2.01 ws	1.79 ws	1.36 ws	1.01 ws	0.79 ws	0.63 ws	0.52 ws	0.44 ws	0.38 * ws	0.33 * ws	0.29 * ws	0.26 * ws	0.23 * ws	0.21 * ws	0.19 * ws	0.18 * ws	0.16 * ws	0.15 * ws
	800S137-43	33	3.98	3.83	3.63	3.38	3.11	2.81	2.51	1.91	1.42	1.11	0.90	0.75	0.63	0.55 *	0.48 *	0.42 *	0.37 *	0.33 *	0.3 *	0.27 *	0.24 *	0.22 *	0.2 *
	800S137-54	50	7.24	6.94	6.43	5.77	5.06	4.33	3.63	2.54	1.90	1.49	1.21	1.01	0.85	0.73 *	0.64 *	0.56 *	0.49 *	0.43 *	0.37 *	0.33 *	0.3 *	0.26 *	0.24 *
	800S137-68	50	10.02	9.42	8.63	7.73	6.75	5.77	4.81	3.38	2.54	1.99	1.61	1.33	1.12	0.94 *	0.79 *	0.67 *	0.58 *	0.51 *	0.45 *	0.39 *	0.35 *	0.32 *	0.28 *
	800S137-97	50	16.03	15.00	13.67	12.14	10.51	8.87	7.29	5.13	3.83	2.94	2.25	1.78	1.44 *	1.19 *	1 *	0.85 *	0.73 *	0.64 *	0.56 *	0.5 *	0.44 *	0.4 *	0.36 *
	800S162-33	33	3.21 ws	3.16 ws	3.08 ws	2.98 ws	2.84 ws	2.68 ws	2.49 ws	2.09 ws	1.68 ws	1.31 ws	1.05 ws	0.86 ws	0.72 ws	0.62 ws	0.54 ws	0.47 ws	0.42 * ws	0.37 * ws	0.34 * ws	0.31 * ws	0.28 * ws	0.26 * ws	0.24 * ws
	800S162-43	33	4.64	4.52	4.37	4.18	3.96	3.71	3.45	2.89	2.34	1.83	1.47	1.21	1.02	0.88	0.76	0.67	0.59 *	0.53 *	0.48 *	0.43 *	0.4 *	0.36 *	0.33 *
	800S162-54	50	8.41	8.19	7.90	7.42	6.82	6.18	5.52	4.22	3.13	2.43	1.96	1.62	1.37	1.17	1.02	0.90	0.79 *	0.71 *	0.64 *	0.58 *	0.52 *	0.46 *	0.42 *
	800S162-68	50	11.65	11.20	10.61	9.89	9.09	8.22	7.33	5.58	4.15	3.24	2.61	2.16	1.82	1.56	1.35	1.18	1.03 *	0.9 *	0.79 *	0.7 *	0.62 *	0.56 *	0.5 *
	800S162-97	50	18.41	17.68	16.70	15.53	14.21	12.80	11.35	8.50	6.33	4.93	3.96	3.23	2.61	2.16	1.81	1.55 *	1.33 *	1.16 *	1.02 *	0.9 *	0.81 *	0.72 *	0.65 *
	800S200-33	33	3.52 ws	3.48 ws	3.42 ws	3.35 ws	3.27 ws	3.18 ws	3.07 ws	2.83 ws	2.54 ws	2.23 ws	1.88 ws	1.54 ws	1.29 ws	1.09 ws	0.94 ws	0.82 ws	0.72 ws	0.65 ws	0.58 ws	0.52 ws	0.48 * ws	0.44 * ws	0.4 * ws
	800S200-43	33	5.34	5.28	5.20	5.08	4.94	4.78	4.58	4.11	3.61	3.09	2.59	2.13	1.78	1.52	1.31	1.15	1.02	0.91	0.82	0.74	0.67 *	0.61 *	0.56 *
	800S200-54	50	9.23	9.12	8.98	8.81	8.61	8.27	7.85	6.66	5.45	4.30	3.43	2.82	2.36	2.02	1.75	1.53	1.36	1.21	1.09	0.98	0.89 *	0.82 *	0.75 *
	800S200-68	50	13.34	13.13	12.86	12.45	11.83	11.13	10.38	8.79	7.19	5.68	4.54	3.74	3.14	2.68	2.33	2.04	1.80	1.60	1.44	1.30	1.17 *	1.05 *	0.94 *
	800S200-97	50	21.43	20.92	20.23	19.37	18.38	17.27	16.08	13.55	11.00	8.64	6.93	5.70	4.78	4.07	3.47	2.96	2.55	2.22	1.95	1.73 *	1.54 *	1.38 *	1.25 *
	800S250-43	33	5.48	5.44	5.39	5.32	5.24	5.15	5.04	4.79	4.51	4.19	3.85	3.39	2.94	2.52	2.18	1.90	1.68	1.49	1.34	1.21	1.09	1.00	0.92
	800S250-54	50	9.50	9.40	9.26	9.08	8.87	8.63	8.36	7.74	7.07	6.51	5.71	4.72	3.93	3.34	2.88	2.51	2.22	1.97	1.77	1.60	1.45	1.33	1.22
	800S250-68	50	13.39	13.27	13.09	12.88	12.63	12.33	12.01	11.16	10.05	8.97	7.53	6.20	5.18	4.41	3.81	3.33	2.94	2.62	2.35	2.12	1.92	1.75	1.61
	800S250-97	50	23.10	22.80	22.40	21.89	21.30	20.65	19.96	18.24	15.99	13.69	11.45	9.41	7.88	6.71	5.79	5.05	4.45	3.93	3.45	3.06	2.73	2.45	2.21
	800S300-54	50	9.66	9.58	9.46	9.32	9.15	8.95	8.72	8.20	7.61	6.97	6.28	5.60	5.00	4.38	3.80	3.33	2.95	2.65	2.39	2.18	2.00	1.84	1.71
800S300-68	50	13.72	13.59	13.43	13.21	12.96	12.66	12.33	11.57	10.75	9.95	9.08	7.95	6.96	5.97	5.20	4.59	4.09	3.69	3.35	3.07	2.83	2.62	2.41	
800S300-97	50	24.49	24.28	24.00	23.64	23.21	22.72	22.03	20.33	18.51	16.71	15.04	13.27	11.41	9.90	8.72	7.66	6.74	5.98	5.35	4.81	4.35	3.90	3.52	
10" Stud	1000S162-43	33	4.65 ws	4.52 ws	4.35 ws	4.14 ws	3.9 ws	3.63 ws	3.35 ws	2.76 ws	2.18 ws	1.7 ws	1.37 ws	1.13 ws	0.96 ws	0.82 ws	0.72 ws	0.64 * ws	0.57 * ws	0.51 * ws	0.46 * ws	0.42 * ws	0.38 * ws	0.35 * ws	0.32 * ws
	1000S162-54	50	8.43	8.18	7.88	7.30	6.66	5.97	5.27	3.91	2.91	2.27	1.84	1.53	1.30	1.12	0.98	0.86 *	0.77 *	0.69 *	0.62 *	0.57 *	0.52 *	0.47 *	0.44 *
	1000S162-68	50	11.69	11.20	10.54	9.76	8.88	7.96	7.01	5.19	3.89	3.05	2.48	2.06	1.75	1.51	1.32	1.16 *	1.03 *	0.92 *	0.83 *	0.75 *	0.67 *	0.6 *	0.54 *
	1000S162-97	50	18.59	17.77	16.69	15.41	13.98	12.46	10.93	8.01	6.04	4.75	3.85	3.20	2.70	2.31	1.95	1.66 *	1.43 *	1.25 *	1.1 *	0.97 *	0.87 *	0.78 *	0.7 *
	1000S200-43	33	5.35 ws	5.29 ws	5.2 ws	5.07 ws	4.92 ws	4.75 ws	4.52 ws	4.02 ws	3.49 ws	2.95 ws	2.44 ws	2 ws	1.68 ws	1.43 ws	1.24 ws	1.09 ws	0.97 ws	0.86 ws	0.78 ws	0.71 * ws	0.64 * ws	0.59 * ws	0.55 * ws
	1000S200-54	50	9.26	9.14	8.99	8.80	8.56	8.20	7.68	6.42	5.17	4.03	3.23	2.66	2.24	1.92	1.66	1.46	1.30	1.16	1.05	0.95 *	0.87 *	0.8 *	0.74 *
	1000S200-68	50	13.41	13.18	12.88	12.40	11.72	10.98	10.18	8.50	6.84	5.35	4.30	3.55	3.00	2.57	2.24	1.97	1.75	1.57	1.41	1.28 *	1.17 *	1.07 *	0.98 *
	1000S200-97	50	21.64	21.08	20.33	19.40	18.32	17.13	15.86	13.19	10.55	8.26	6.67	5.53	4.67	4.01	3.48	3.05	2.70	2.39	2.10	1.86 *	1.66 *	1.49 *	1.35 *
	1000S250-43	33	5.5 ws	5.46 ws	5.4 ws	5.33 ws	5.25 ws	5.16 ws	5.05 ws	4.79 ws	4.5 ws	4.16 ws	3.79 ws	3.3 ws	2.83 ws	2.4 ws	2.07 ws	1.81 ws	1.59 ws	1.42 ws	1.27 ws	1.15 ws	1.05 ws	0.96 ws	0.88 ws
	1000S250-54	50	9.53	9.43	9.29	9.11	8.89	8.63	8.35	7.70	7.02	6.37	5.46	4.46	3.73	3.17	2.74	2.40	2.12	1.89	1.70	1.54	1.40	1.29	1.18
	1000S250-68	50	13.47	13.34	13.15	12.93	12.66	12.35	12.00	11.04	9.88	8.66	7.19	5.90	4.94	4.22	3.66	3.21	2.84	2.54	2.28	2.07	1.88	1.73	1.59
	1000S250-97	50	23.33	23.01	22.57	22.03	21.40	20.71	19.99	18.05	15.69	13.31	11.00	9.07	7.63	6.53	5.67	4.97	4.40	3.93	3.53	3.19	2.90	2.64	2.39
	1000S300-54	50	9.71	9.64	9.54	9.42	9.27	9.09	8.90	8.44	7.92	7.34	6.71	6.05	5.45	4.83	4.22	3.68	3.24	2.88	2.58	2.33	2.12	1.93	1.77
	1000S300-68	50	13.81	13.71	13.56	13.38	13.15	12.89	12.60	11.92	11.13	10.38	9.59	8.54	7.48	6.46	5.57	4.87	4.30	3.83	3.43	3.10	2.82	2.58	2.37
1000S300-97	50	24.75	24.57	24.31	23.99	23.60	23.15	22.59	20.96	19.17	17.32	15.54	13.68	11.60	9.89	8.56	7.49	6.62	5.91	5.31	4.80	4.36	3.98	3.65	

Notes:

- For additional general notes, see page 56.
- Listed axial loads marked with "*" indicate the $KL/r > 300$.
- Listed axial loads marked with "ws" indicate that $h/t > 200$.
This indicates that web stiffeners are required to prevent web crippling at points of concentrated loads.
- Listed capacities are calculated per AISI S100-16 (2020) w/S2-20.

Complies with AISI S100-16 (2020) w/S2-20 • IBC 2024

ALLOWABLE UNBRACED AXIAL LOADS

Based on length (Kips)

Member	F _y (ksi)	Unbraced Length (ft)																							
		1	1.5	2	2.5	3	3.5	4	5	6	7	8	9	10	11	12	13	14	15	16	17	18	19	20	
12" Stud	1200S162-54	50	8.43 ws	8.16 ws	7.8 ws	7.17 ws	6.47 ws	5.74 ws	5.01 ws	3.63 ws	2.71 ws	2.12 ws	1.72 ws	1.44 ws	1.22 ws	1.06 ws	0.93 ws	0.82 * ws	0.73 * ws	0.66 * ws	0.6 * ws	0.55 * ws	0.5 * ws	0.46 * ws	0.43 * ws
	1200S162-68	50	11.70	11.15	10.44	9.59	8.65	7.67	6.68	4.84	3.64	2.87	2.34	1.96	1.67	1.44	1.27 *	1.12 *	1 *	0.9 *	0.81 *	0.74 *	0.68 *	0.62 *	0.57 *
	1200S162-97	50	18.66	17.77	16.59	15.19	13.65	12.04	10.43	7.54	5.72	4.53	3.70	3.09	2.63	2.27	1.98 *	1.74 *	1.51 *	1.31 *	1.15 *	1.02 *	0.91 *	0.82 *	0.74 *
	1200S200-54	50	9.27 ws	9.15 ws	8.98 ws	8.78 ws	8.49 ws	8.11 ws	7.49 ws	6.17 ws	4.88 ws	3.78 ws	3.03 ws	2.5 ws	2.11 ws	1.81 ws	1.58 ws	1.39 ws	1.24 ws	1.11 ws	1.01 ws	0.91 * ws	0.84 * ws	0.77 * ws	0.71 * ws
	1200S200-68	50	13.44	13.19	12.88	12.30	11.58	10.79	9.94	8.18	6.47	5.03	4.06	3.36	2.85	2.45	2.14	1.89	1.68	1.51	1.37 *	1.25 *	1.14 *	1.05 *	0.97 *
	1200S200-97	50	21.74	21.14	20.32	19.31	18.15	16.88	15.53	12.73	10.00	7.84	6.36	5.30	4.50	3.88	3.38	2.99	2.66	2.38	2.14 *	1.94 *	1.76 *	1.58 *	1.42 *
	1200S250-54	50	9.55 ws	9.44 ws	9.29 ws	9.09 ws	8.86 ws	8.59 ws	8.28 ws	7.59 ws	6.92 ws	6.18 ws	5.15 ws	4.21 ws	3.53 ws	3.01 ws	2.6 ws	2.28 ws	2.02 ws	1.81 ws	1.63 ws	1.48 ws	1.35 ws	1.23 ws	1.14 ws
	1200S250-68	50	13.51	13.37	13.17	12.93	12.64	12.31	11.94	10.86	9.67	8.31	6.80	5.59	4.70	4.02	3.49	3.06	2.72	2.44	2.20	2.00	1.82	1.67	1.54
	1200S250-97	50	23.46	23.11	22.64	22.06	21.39	20.66	19.91	17.75	15.28	12.82	10.48	8.66	7.32	6.28	5.47	4.82	4.28	3.84	3.46	3.14	2.87	2.63	2.42 *
	1200S300-54	50	9.73 ws	9.65 ws	9.55 ws	9.42 ws	9.26 ws	9.08 ws	8.87 ws	8.4 ws	7.84 ws	7.22 ws	6.57 ws	5.88 ws	5.3 ws	4.66 ws	4.02 ws	3.5 ws	3.09 ws	2.75 ws	2.47 ws	2.23 ws	2.03 ws	1.86 ws	1.71 ws
	1200S300-68	50	13.85	13.74	13.59	13.39	13.15	12.88	12.57	11.84	11.03	10.25	9.43	8.27	7.22	6.16	5.32	4.66	4.12	3.67	3.30	2.99	2.72	2.49	2.29
	1200S300-97	50	24.89	24.69	24.42	24.08	23.66	23.18	22.53	20.82	18.95	17.04	15.25	13.19	11.12	9.51	8.25	7.24	6.42	5.74	5.17	4.69	4.27	3.91	3.60
14" Stud	1400S162-54	50	8.42 ws	8.14 ws	7.7 ws	7.03 ws	6.29 ws	5.52 ws	4.75 ws	3.38 ws	2.53 ws	1.99 ws	1.62 ws	1.36 ws	1.16 ws	1 ws	0.88 * ws	0.78 * ws	0.7 * ws	0.63 * ws	0.58 * ws	0.53 * ws	0.48 * ws	0.45 * ws	0.41 * ws
	1400S162-68	50	11.69	11.09	10.32	9.40	8.41	7.37	6.34	4.53	3.42	2.70	2.21	1.86	1.59	1.38	1.21 *	1.08 *	0.96 *	0.87 *	0.79 *	0.72 *	0.66 *	0.61 *	0.56 *
	1400S162-97	50	18.69	17.71	16.43	14.92	13.28	11.59	9.91	7.11	5.42	4.31	3.54	2.98	2.54	2.2 *	1.93 *	1.71 *	1.52 *	1.36 *	1.2 *	1.06 *	0.95 *	0.85 *	0.77 *
	1400S200-54	50	9.28 ws	9.15 ws	8.97 ws	8.75 ws	8.42 ws	7.96 ws	7.29 ws	5.91 ws	4.58 ws	3.55 ws	2.85 ws	2.36 ws	1.99 ws	1.71 ws	1.5 ws	1.32 ws	1.18 ws	1.06 ws	0.96 * ws	0.88 * ws	0.8 * ws	0.74 * ws	0.68 * ws
	1400S200-68	50	13.46	13.19	12.85	12.19	11.42	10.58	9.68	7.85	6.08	4.74	3.83	3.18	2.70	2.33	2.04	1.81	1.61	1.45	1.32 *	1.2 *	1.1 *	1.01 *	0.94 *
	1400S200-97	50	21.80	21.14	20.26	19.17	17.94	16.58	15.15	12.23	9.45	7.44	6.06	5.06	4.31	3.73	3.27	2.89	2.58	2.32 *	2.1 *	1.91 *	1.75 *	1.6 *	1.47 *
	1400S250-54	50	9.56 ws	9.44 ws	9.28 ws	9.07 ws	8.82 ws	8.53 ws	8.21 ws	7.47 ws	6.8 ws	5.98 ws	4.86 ws	3.98 ws	3.34 ws	2.85 ws	2.47 ws	2.17 ws	1.92 ws	1.72 ws	1.55 ws	1.41 ws	1.29 ws	1.18 ws	1.09 * ws
	1400S250-68	50	13.53	13.38	13.17	12.91	12.60	12.25	11.86	10.67	9.46	7.94	6.43	5.29	4.46	3.82	3.32	2.92	2.60	2.33	2.11	1.92	1.75	1.61	1.49 *
	1400S250-97	50	23.54	23.16	22.65	22.04	21.33	20.56	19.79	17.38	14.81	12.28	9.97	8.26	6.99	6.02	5.26	4.64	4.14	3.72	3.36	3.06	2.80	2.57	2.37 *
	1400S300-54	50	9.74 ws	9.66 ws	9.55 ws	9.41 ws	9.25 ws	9.05 ws	8.83 ws	8.33 ws	7.74 ws	7.09 ws	6.41 ws	5.7 ws	5.08 ws	4.44 ws	3.82 ws	3.34 ws	2.95 ws	2.62 ws	2.36 ws	2.13 ws	1.94 ws	1.78 ws	1.63 ws
	1400S300-68	50	13.88	13.76	13.60	13.39	13.14	12.84	12.51	11.75	10.91	10.10	9.16	7.97	6.89	5.87	5.08	4.45	3.94	3.52	3.17	2.87	2.62	2.40	2.21
	1400S300-97	50	24.98	24.77	24.48	24.11	23.67	23.16	22.42	20.61	18.66	16.70	14.90	12.64	10.64	9.11	7.91	6.96	6.18	5.54	5.00	4.54	4.15	3.81	3.51

Notes:

- 1 For additional general notes, see page 56.
- 2 Listed axial loads marked with " * " indicate the KL/r > 300.
- 3 Listed axial loads marked with "ws" indicate that h/t > 200. This indicates that web stiffeners are required to prevent web crippling at points of concentrated loads.
- 4 Listed capacities are calculated per AISI S100-16 (2020) w/S2-20.

Complies with AISI S100-16 (2020) w/S2-20 • IBC 2024



FLOOR JOIST FRAMING



Overview

General Notes:

- 1 Spans are based on continuous support of compression flange over the full length of the joist.
- 2 Joist deflection limitations are based upon $L/240$ for the total load (TL) and $L/360$ or $L/480$ for live load (LL).
- 3 For two equal spans, the listed span is the distance from either end to the center support, with the joist continuous over the center support.
- 4 Joists must be braced against rotation at all supports.
- 5 For two equal, continuous span conditions, alternate span live load has been considered.
- 6 The strength increase due to cold work of forming was incorporated for flexural strength as applicable per AISI S100.
- 7 The yield stress (33ksi or 50ksi) used to calculate tabulated values are indicated in each table.
- 8 A 3-1/2" bearing length was used at all support locations in the preparation of these tables. Joist flanges must be fastened to the support.
- 9 A punchout pattern for ClarkDietrich joists is a 4" long by 1-1/2" high oval.
- 10 Unpunched joists are available, but must be indicated when ordering.
- 11 Web punchouts located near a bearing location may need reinforcement.
- 12 Listed capacities are calculated per AISI S100-16 (2020) w/S2-20. Stud distortional buckling based on an assumed $K\phi = 0$.
- 13 Joist bridging opposite the sheathed flange is recommended at a maximum of 8 ft o.c. when sheathing is applied to only the compression flange.
- 14 Web punchouts are not considered for shear and web crippling.
- 15 Deflection checks are computed using unbalanced loads for the two equal span conditions.
- 16 "e" indicates that the web stiffeners are required at the end support only.
- 17 "i" indicates that the web stiffeners are required at the interior support only.
- 18 "a" indicates that the web stiffeners are required at all supports.

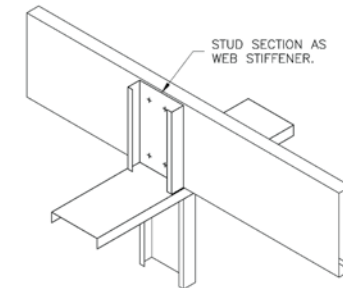
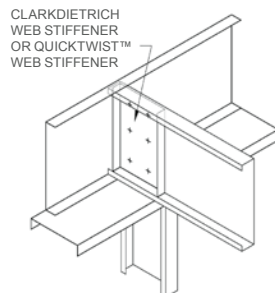
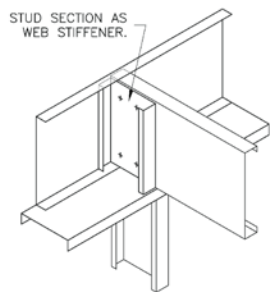
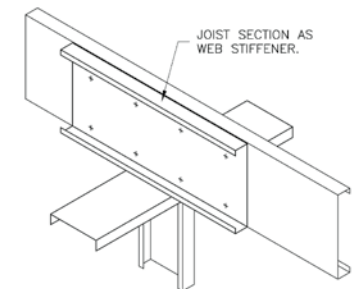
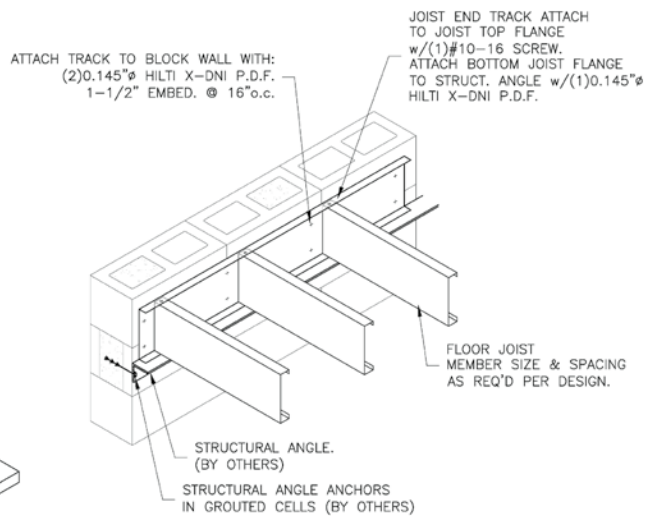
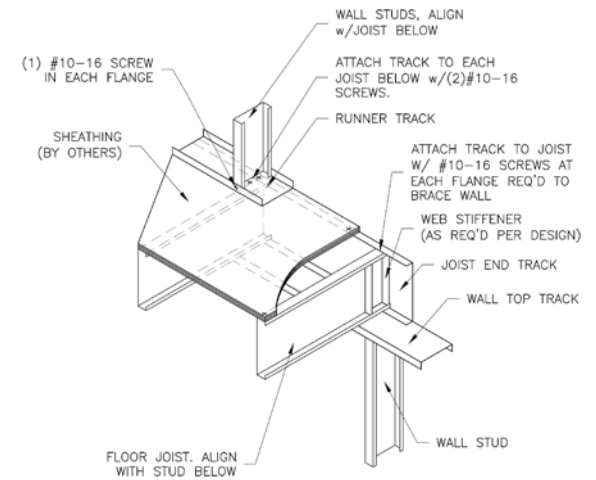
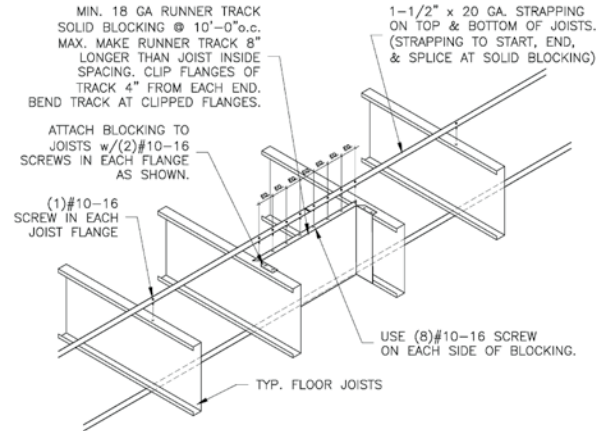

Complies with AISI S100-16 (2020) w/S2-20 • IBC 2024

FLOOR JOIST SPAN LIMITATIONS

10psf Dead Load and 20psf Live Load (TL Deflection=L/240)

Member	Yield strength F _y (ksi)	Live Load Deflection L/360						Live Load Deflection L/480					
		Single span spacing (in) o.c.			Two equal span spacing (in) o.c.			Single span spacing (in) o.c.			Two equal span spacing (in) o.c.		
		12	16	24	12	16	24	12	16	24	12	16	24
600S137-33	33	13' 2"	11' 5"	9' 4" e	13' 2" i	11' 5" i	9' 4" i	13' 2"	11' 5"	9' 4" e	13' 2" i	11' 5" i	9' 4" i
600S137-43	33	15' 10"	13' 8"	11' 2"	15' 10" i	13' 8" i	11' 2" i	14' 11"	13' 7"	11' 2"	15' 10" i	13' 8" i	11' 2" i
600S137-54	50	17' 8"	16' 0"	14' 0"	19' 10"	18' 0" i	14' 11" i	16' 0"	14' 7"	12' 9"	18' 0"	16' 4"	14' 4" i
600S137-68	50	18' 11"	17' 2"	15' 0"	21' 3"	19' 3"	16' 10" i	17' 2"	15' 7"	13' 8"	19' 3"	17' 6"	15' 4"
600S137-97	50	20' 11"	19' 0"	16' 7"	23' 6"	21' 4"	18' 8"	19' 0"	17' 3"	15' 1"	21' 4"	19' 5"	16' 11"
600S162-33	33	14' 3"	12' 4" e	10' 1" e	14' 3" i	12' 4" i	10' 1" a	14' 3"	12' 4" e	10' 1" e	14' 3" i	12' 4" i	10' 1" a
600S162-43	33	17' 0"	14' 9"	12' 1"	17' 0" i	14' 9" i	12' 1" i	15' 7"	14' 2"	12' 1"	17' 0" i	14' 9" i	12' 1" i
600S162-54	50	18' 5"	16' 9"	14' 7"	20' 8"	18' 9" i	16' 1" i	16' 9"	15' 2"	13' 3"	18' 9"	17' 1"	14' 11" i
600S162-68	50	19' 9"	17' 11"	15' 8"	22' 2"	20' 2"	17' 7" i	17' 11"	16' 4"	14' 3"	20' 2"	18' 4"	16' 0"
600S162-97	50	21' 11"	19' 11"	17' 4"	24' 7"	22' 4"	19' 6"	19' 11"	18' 1"	15' 9"	22' 4"	20' 3"	17' 9"
600S200-33	33	15' 3"	13' 2" e	10' 9" e	15' 3" i	13' 2" i	10' 9" a	15' 0"	13' 2" e	10' 9" e	15' 3" i	13' 2" i	10' 9" a
600S200-43	33	18' 0"	15' 9"	12' 11"	18' 3" i	15' 9" i	12' 11" i	16' 5"	14' 11"	12' 11"	18' 3" i	15' 9" i	12' 11" i
600S200-54	50	19' 4"	17' 7"	15' 4"	21' 9"	19' 9" i	17' 2" i	17' 7"	16' 0"	14' 0"	19' 9"	17' 11"	15' 8" i
600S200-68	50	20' 9"	18' 10"	16' 6"	23' 4"	21' 2"	18' 6" i	18' 10"	17' 2"	15' 0"	21' 2"	19' 3"	16' 10"
600S200-97	50	23' 1"	20' 11"	18' 4"	25' 11"	23' 6"	20' 7"	20' 11"	19' 0"	16' 8"	23' 6"	21' 4"	18' 8"
600S250-43	33	18' 8"	16' 2"	13' 3"	18' 8" i	16' 2" i	13' 3" i	17' 2"	15' 7"	13' 3"	18' 8" i	16' 2" i	13' 3" i
600S250-54	50	20' 2"	18' 4"	16' 0"	22' 8"	20' 7" i	17' 7" i	18' 4"	16' 8"	14' 7"	20' 7"	18' 9"	16' 4" i
600S250-68	50	21' 9"	19' 9"	17' 3"	24' 5"	22' 3"	19' 5" i	19' 9"	18' 0"	15' 8"	22' 3"	20' 2"	17' 8"
600S250-97	50	24' 3"	22' 0"	19' 3"	27' 2"	24' 8"	21' 7"	22' 0"	20' 0"	17' 6"	24' 8"	22' 5"	19' 7"
600S300-54	50	20' 7"	18' 9"	16' 4"	23' 2" i	21' 0" i	17' 10" i	18' 9"	17' 0"	14' 10"	21' 0"	19' 1"	16' 8" i
600S300-68	50	22' 6"	20' 5"	17' 10"	25' 3"	23' 0"	20' 1" i	20' 5"	18' 7"	16' 3"	23' 0"	20' 10"	18' 3" i
600S300-97	50	25' 2"	22' 10"	20' 0"	28' 3"	25' 8"	22' 5"	22' 10"	20' 9"	18' 2"	25' 8"	23' 4"	20' 4"
800S137-33	33	15' 1" e	13' 1" e	10' 8" e	15' 1" a	13' 1" a	9' 11" a	15' 1" e	13' 1" e	10' 8" e	15' 1" a	13' 1" a	9' 11" a
800S137-43	33	18' 4"	15' 10"	12' 11" e	18' 4" i	15' 10" i	12' 11" i	18' 4"	15' 10"	12' 11" e	18' 4" i	15' 10" i	12' 11" i
800S137-54	50	22' 2"	20' 2"	17' 4"	24' 6" i	21' 3" i	17' 4" i	20' 2"	18' 3"	16' 0"	22' 7" i	20' 6" i	17' 4" i
800S137-68	50	23' 11"	21' 9"	19' 0"	26' 11"	24' 5" i	20' 5" i	21' 9"	19' 9"	17' 3"	24' 5" i	22' 2"	19' 5" i
800S137-97	50	26' 7"	24' 2"	21' 1"	29' 10"	27' 1"	23' 8"	24' 2"	21' 11"	19' 2"	27' 1"	24' 8"	21' 6"
800S162-33	33	16' 6" e	14' 3" e	11' 8" e	16' 6" a	13' 10" a	10' 4" a	16' 6" e	14' 3" e	11' 8" e	16' 6" a	13' 10" a	10' 4" a
800S162-43	33	19' 10"	17' 2"	14' 0" e	19' 10" i	17' 2" i	14' 0" i	19' 6"	17' 2"	14' 0" e	19' 10" i	17' 2" i	14' 0" i
800S162-54	50	23' 1"	20' 11"	18' 3"	25' 10" i	22' 11" i	18' 9" i	20' 11"	19' 0"	16' 7"	23' 6"	21' 4" i	18' 8" i
800S162-68	50	24' 11"	22' 8"	19' 9"	28' 0"	25' 5" i	21' 11" i	22' 8"	20' 7"	18' 0"	25' 5" i	23' 1"	20' 2" i
800S162-97	50	27' 8"	25' 2"	22' 0"	31' 1"	28' 3"	24' 8"	25' 2"	22' 10"	20' 0"	28' 3"	25' 8"	22' 5"

Notes:

- 1 Web punchouts are not considered for shear and web crippling.
- 2 Deflection checks are computed using unbalanced loads for the two equal span conditions.
- 3 "e" indicates that the web stiffeners are required at the end support only.
- 4 "i" indicates that the web stiffeners are required at the interior support only.
- 5 "a" indicates that the web stiffeners are required at all supports.
- 6 See additional floor joist notes on page 62.

Complies with AISI S100-16 (2020) w/S20-20 • IBC 2024

FLOOR JOIST SPAN LIMITATIONS

10psf Dead Load and 20psf Live Load (TL Deflection=L/240)

Member	Yield strength F _y (ksi)	Live Load Deflection L/360						Live Load Deflection L/480					
		Single span spacing (in) o.c.			Two equal span spacing (in) o.c.			Single span spacing (in) o.c.			Two equal span spacing (in) o.c.		
		12	16	24	12	16	24	12	16	24	12	16	24
800S200-33	33	17' 9" e	15' 4" e	12' 6" e	17' 8" a	14' 6" a	10' 9" a	17' 9" e	15' 4" e	12' 6" e	17' 8" a	14' 6" a	10' 9" a
800S200-43	33	21' 4"	18' 5"	15' 1" e	21' 4" i	18' 5" i	15' 1" i	20' 7"	18' 5"	15' 1" e	21' 4" i	18' 5" i	15' 1" i
800S200-54	50	24' 4"	22' 1"	19' 4"	27' 3" i	24' 7" i	20' 1" i	22' 1"	20' 1"	17' 6"	24' 10"	22' 6" i	19' 8" i
800S200-68	50	26' 1"	23' 9"	20' 9"	29' 4"	26' 8" i	23' 3" i	23' 9"	21' 7"	18' 10"	26' 8"	24' 2"	21' 2" i
800S200-97	50	29' 0"	26' 5"	23' 1"	32' 7"	29' 7"	25' 11"	26' 5"	24' 0"	20' 11"	29' 7"	26' 11"	23' 6"
800S250-43	33	21' 10"	18' 11"	15' 5" e	21' 10" i	18' 11" i	15' 5" a	21' 5"	18' 11"	15' 5" e	21' 10" i	18' 11" i	15' 5" a
800S250-54	50	25' 3"	22' 11"	20' 1"	28' 4" i	25' 2" i	20' 6" i	22' 11"	20' 10"	18' 3"	25' 9" i	23' 5" i	20' 5" i
800S250-68	50	27' 3"	24' 9"	21' 7"	30' 7"	27' 9" i	24' 0" i	24' 9"	22' 6"	19' 8"	27' 9"	25' 3"	22' 1" i
800S250-97	50	30' 4"	27' 7"	24' 1"	34' 1"	30' 11"	27' 1"	27' 7"	25' 1"	21' 11"	30' 11"	28' 2"	24' 7"
800S300-54	50	25' 10"	23' 5"	20' 6"	29' 0" i	25' 6" i	20' 10" i	23' 5"	21' 4"	18' 7"	26' 4" i	23' 11" i	20' 10" i
800S300-68	50	28' 0"	25' 6"	22' 3"	31' 6"	28' 7" i	24' 5" i	25' 6"	23' 2"	20' 3"	28' 7"	26' 0"	22' 8" i
800S300-97	50	31' 5"	28' 6"	24' 11"	35' 3"	32' 0"	28' 0"	28' 6"	25' 11"	22' 8"	32' 0"	29' 1"	25' 5"
1000S162-43	33	22' 0" e	19' 1" e	15' 7" e	22' 0" a	19' 1" a	15' 7" a	22' 0" e	19' 1" e	15' 7" e	22' 0" a	19' 1" a	15' 7" a
1000S162-54	50	27' 5"	24' 10"	20' 10"	29' 5" i	25' 6" i	20' 10" i	24' 10"	22' 7"	19' 9"	27' 11" i	25' 4" i	20' 10" i
1000S162-68	50	29' 8"	27' 0"	23' 7"	33' 4" i	30' 1" i	24' 6" i	27' 0"	24' 6"	21' 5"	30' 3"	27' 6" i	24' 0" i
1000S162-97	50	33' 4"	30' 4"	26' 6"	37' 5"	34' 0"	29' 9" i	30' 4"	27' 6"	24' 1"	34' 0"	30' 11"	27' 0"
1000S200-43	33	23' 10" e	20' 7" e	16' 10" e	23' 10" a	20' 7" a	16' 4" a	23' 10" e	20' 7" e	16' 10" e	23' 10" a	20' 7" a	16' 4" a
1000S200-54	50	28' 8"	26' 0"	22' 5"	31' 9" i	27' 6" i	22' 5" i	26' 0"	23' 8"	20' 8"	29' 3" i	26' 7" i	22' 5" i
1000S200-68	50	31' 0"	28' 2"	24' 7"	34' 10" i	31' 8" i	26' 4" i	28' 2"	25' 7"	22' 4"	31' 8"	28' 9" i	25' 1" i
1000S200-97	50	34' 10"	31' 8"	27' 8"	39' 1"	35' 6"	31' 0"	31' 8"	28' 9"	25' 1"	35' 6"	32' 3"	28' 2"
1000S250-54	50	30' 3"	27' 6"	23' 1"	32' 7" i	28' 3" i	23' 1" i	27' 6"	25' 0"	21' 10"	30' 10" i	28' 0" i	23' 1" i
1000S250-68	50	32' 6"	29' 7"	25' 10"	36' 6" i	33' 2" i	27' 1" i	29' 7"	26' 10"	23' 5"	33' 2"	30' 2" i	26' 4" i
1000S250-97	50	36' 3"	32' 11"	28' 9"	40' 9"	37' 0"	32' 4" i	32' 11"	29' 11"	26' 2"	37' 0"	33' 7"	29' 4"
1000S300-54	50	30' 10"	28' 0"	23' 5"	33' 1" i	28' 8" i	23' 5" i	28' 0"	25' 6"	22' 3"	31' 6" i	28' 7" i	23' 5" i
1000S300-68	50	33' 5"	30' 4"	26' 6"	37' 6" i	33' 9" i	27' 7" i	30' 4"	27' 7"	24' 1"	34' 1"	31' 0" i	27' 1" i
1000S300-97	50	37' 5"	34' 0"	29' 8"	42' 0"	38' 2"	33' 4" i	34' 0"	30' 11"	27' 0"	38' 2"	34' 8"	30' 4"
1200S162-54	50	31' 6" e	27' 5" e	22' 5" e	31' 8" a	27' 5" a	22' 5" a	28' 7" e	26' 0" e	22' 5" e	31' 8" a	27' 5" a	22' 5" a
1200S162-68	50	34' 3"	31' 1"	26' 7"	37' 8" i	32' 7" i	26' 7" i	31' 1"	28' 3"	24' 8"	34' 11" i	31' 9" i	26' 7" i
1200S162-97	50	38' 10"	35' 3"	30' 10"	43' 7"	39' 7"	34' 5" i	35' 3"	32' 0"	28' 0"	39' 7"	36' 0"	31' 5"
1200S200-54	50	32' 11" e	29' 10" e	24' 4" e	34' 5" a	29' 10" a	24' 4" a	29' 11" e	27' 2" e	23' 9" e	33' 7" a	29' 10" a	24' 4" a
1200S200-68	50	35' 9"	32' 5"	28' 4"	40' 1" i	35' 2" i	28' 9" i	32' 5"	29' 6"	25' 9"	36' 5" i	33' 1" i	28' 9" i
1200S200-97	50	40' 5"	36' 8"	32' 1"	45' 4"	41' 3"	36' 0" i	36' 8"	33' 4"	29' 2"	41' 3"	37' 5"	32' 9"

Notes:

- 1 Web punchouts are not considered for shear and web crippling.
- 2 Deflection checks are computed using unbalanced loads for the two equal span conditions.
- 3 "e" indicates that the web stiffeners are required at the end support only.
- 4 "i" indicates that the web stiffeners are required at the interior support only.
- 5 "a" indicates that the web stiffeners are required at all supports.
- 6 See additional floor joist notes on page 62.

Complies with AISI S100-16 (2020) w/S20-0 • IBC 2024

FLOOR JOIST SPAN LIMITATIONS

10psf Dead Load and 20psf Live Load (TL Deflection=L/240)

Member	Yield strength F _y (ksi)	Live Load Deflection L/360						Live Load Deflection L/480					
		Single span spacing (in) o.c.			Two equal span spacing (in) o.c.			Single span spacing (in) o.c.			Two equal span spacing (in) o.c.		
		12	16	24	12	16	24	12	16	24	12	16	24
1200S250-54	50	34' 3" e	30' 10" e	25' 2" e	35' 7" a	30' 10" a	25' 2" a	31' 2" e	28' 4" e	24' 9" e	35' 0" a	30' 10" a	25' 2" a
1200S250-68	50	37' 3"	33' 10"	29' 6"	41' 9" i	36' 4" i	29' 8" i	33' 10"	30' 9"	26' 10"	37' 11" i	34' 6" i	29' 8" i
1200S250-97	50	42' 0"	38' 2"	33' 4"	47' 1"	42' 10"	37' 5" i	38' 2"	34' 8"	30' 3"	42' 10"	38' 11"	34' 0"
1200S300-54	50	35' 10" e	31' 5" e	25' 8" e	36' 3" a	31' 5" a	25' 8" a	32' 7" e	29' 7" e	25' 8" e	36' 3" a	31' 5" a	25' 8" a
1200S300-68	50	38' 8"	35' 2"	30' 3"	42' 10" i	37' 1" i	30' 3" i	35' 2"	31' 11"	27' 11"	39' 6" i	35' 10" i	30' 3" i
1200S300-97	50	43' 3"	39' 4"	34' 4"	48' 7"	44' 2"	38' 7" i	39' 4"	35' 9"	31' 2"	44' 2"	40' 1"	35' 0" i
1400S162-54	50	33' 6" e	29' 0" e	23' 8" e	33' 6" a	29' 0" a	23' 0" a	32' 2" e	29' 0" e	23' 8" e	33' 6" a	29' 0" a	23' 0" a
1400S162-68	50	38' 8"	34' 7"	28' 3"	40' 0" i	34' 7" i	28' 3" i	35' 1"	31' 11"	27' 10"	39' 5" i	34' 7" i	28' 3" i
1400S162-97	50	44' 0"	39' 11"	34' 11"	49' 4"	44' 10" i	36' 11" i	39' 11"	36' 4"	31' 8"	44' 10"	40' 9"	35' 7" i
1400S200-54	50	36' 7" e	31' 8" e	25' 10" e	36' 7" a	31' 8" a	24' 3" a	33' 8" e	30' 7" e	25' 10" e	36' 7" a	31' 8" a	24' 3" a
1400S200-68	50	40' 3"	36' 7"	30' 8"	43' 5" i	37' 7" i	30' 8" i	36' 7"	33' 3"	29' 0"	41' 0" i	37' 3" i	30' 8" i
1400S200-97	50	45' 8"	41' 6"	36' 3"	51' 3"	46' 7" i	39' 9" i	41' 6"	37' 8"	32' 11"	46' 7"	42' 4"	37' 0" i
1400S250-54	50	38' 0" e	32' 11" e	26' 11" e	38' 0" a	32' 11" a	24' 9" a	35' 0" e	31' 10" e	26' 11" e	38' 0" a	32' 11" a	24' 9" a
1400S250-68	50	41' 10"	38' 0"	31' 10"	45' 1" i	39' 0" i	31' 10" i	38' 0"	34' 7"	30' 2"	42' 8" i	38' 10" i	31' 10" i
1400S250-97	50	47' 4"	43' 0"	37' 7"	53' 2"	48' 4" i	41' 3" i	43' 0"	39' 1"	34' 2"	48' 4"	43' 11"	38' 4" i
1400S300-54	50	38' 11" e	33' 9" e	27' 6" e	38' 11" a	33' 5" a	25' 1" a	35' 6" e	32' 3" e	27' 6" e	38' 11" a	33' 5" a	25' 1" a
1400S300-68	50	43' 0"	39' 0"	32' 7"	46' 2" i	39' 11" i	32' 7" i	39' 0"	35' 6"	31' 0"	43' 10" i	39' 10" i	32' 7" i
1400S300-97	50	48' 10"	44' 4"	38' 9"	54' 10"	49' 10" i	42' 3" i	44' 4"	40' 4"	35' 2"	49' 10"	45' 3"	39' 6" i

Notes:

- 1 Web punchouts are not considered for shear and web crippling.
- 2 Deflection checks are computed using unbalanced loads for the two equal span conditions.
- 3 "e" indicates that the web stiffeners are required at the end support only.
- 4 "i" indicates that the web stiffeners are required at the interior support only.
- 5 "a" indicates that the web stiffeners are required at all supports.
- 6 See additional floor joist notes on page 62.

Complies with AISI S100-16 (2020) w/S2-20 • IBC 2024

The technical content of this literature is effective 06/01/24 and supersedes all previous information.

FLOOR JOIST SPAN LIMITATIONS

10psf Dead Load and 30psf Live Load (TL Deflection=L/240)

Member	Yield strength F _y (ksi)	Live Load Deflection L/360						Live Load Deflection L/480					
		Single span spacing (in) o.c.			Two equal span spacing (in) o.c.			Single span spacing (in) o.c.			Two equal span spacing (in) o.c.		
		12	16	24	12	16	24	12	16	24	12	16	24
600S137-33	33	11' 5"	9' 11" e	8' 1" e	11' 5" i	9' 11" i	8' 1" a	11' 5"	9' 11" e	8' 1" e	11' 5" i	9' 11" i	8' 1" a
600S137-43	33	13' 8"	11' 10"	9' 8"	13' 8" i	11' 10" i	9' 8" i	13' 1"	11' 10"	9' 8"	13' 8" i	11' 10" i	9' 8" i
600S137-54	50	15' 5"	14' 0"	12' 3"	17' 4" i	15' 9" i	12' 11" i	14' 0"	12' 9"	11' 1"	15' 9"	14' 4" i	12' 6" i
600S137-68	50	16' 6"	15' 0"	13' 1"	18' 7"	16' 10"	14' 9" i	15' 0"	13' 8"	11' 11"	16' 10"	15' 4"	13' 4"
600S137-97	50	18' 3"	16' 7"	14' 6"	20' 6"	18' 8"	16' 3"	16' 7"	15' 1"	13' 2"	18' 8"	16' 11"	14' 10"
600S162-33	33	12' 4" e	10' 8" e	8' 9" e	12' 4" i	10' 8" a	8' 9" a	12' 4" e	10' 8" e	8' 9" e	12' 4" i	10' 8" a	8' 9" a
600S162-43	33	14' 9"	12' 9"	10' 5" e	14' 9" i	12' 9" i	10' 5" i	13' 8"	12' 5"	10' 5" e	14' 9" i	12' 9" i	10' 5" i
600S162-54	50	16' 1"	14' 7"	12' 9"	18' 1" i	16' 5" i	13' 11" i	14' 7"	13' 3"	11' 7"	16' 5"	14' 11"	13' 0" i
600S162-68	50	17' 3"	15' 8"	13' 8"	19' 4"	17' 7"	15' 4" i	15' 8"	14' 3"	12' 5"	17' 7"	16' 0"	14' 0"
600S162-97	50	19' 1"	17' 4"	15' 2"	21' 6"	19' 6"	17' 0"	17' 4"	15' 9"	13' 9"	19' 6"	17' 9"	15' 6"
600S200-33	33	13' 2" e	11' 5" e	9' 4" e	13' 2" i	11' 5" a	9' 2" a	13' 1" e	11' 5" e	9' 4" e	13' 2" i	11' 5" a	9' 2" a
600S200-43	33	15' 9"	13' 8"	11' 2" e	15' 9" i	13' 8" i	11' 2" i	14' 4"	13' 0"	11' 2" e	15' 9" i	13' 8" i	11' 2" i
600S200-54	50	16' 11"	15' 4"	13' 5"	19' 0" i	17' 3" i	14' 10" i	15' 4"	14' 0"	12' 2"	17' 3"	15' 8"	13' 8" i
600S200-68	50	18' 2"	16' 6"	14' 5"	20' 4"	18' 6"	16' 2" i	16' 6"	15' 0"	13' 1"	18' 6"	16' 10"	14' 8"
600S200-97	50	20' 2"	18' 4"	16' 0"	22' 7"	20' 7"	17' 11"	18' 4"	16' 8"	14' 6"	20' 7"	18' 8"	16' 4"
600S250-43	33	16' 2"	14' 0"	11' 5" e	16' 2" i	14' 0" i	11' 5" i	15' 0"	13' 7"	11' 5" e	16' 2" i	14' 0" i	11' 5" i
600S250-54	50	17' 8"	16' 0"	14' 0"	19' 10" i	18' 0" i	15' 2" i	16' 0"	14' 7"	12' 9"	18' 0"	16' 4" i	14' 3" i
600S250-68	50	19' 0"	17' 3"	15' 1"	21' 4"	19' 5"	16' 11" i	17' 3"	15' 8"	13' 9"	19' 5"	17' 8"	15' 5"
600S250-97	50	21' 2"	19' 3"	16' 9"	23' 9"	21' 7"	18' 10"	19' 3"	17' 6"	15' 3"	21' 7"	19' 7"	17' 2"
600S300-54	50	18' 0"	16' 4"	14' 4"	20' 3" i	18' 5" i	15' 6" i	16' 4"	14' 10"	13' 0"	18' 5"	16' 8" i	14' 7" i
600S300-68	50	19' 8"	17' 10"	15' 7"	22' 1"	20' 1"	17' 6" i	17' 10"	16' 3"	14' 2"	20' 1"	18' 3"	15' 11" i
600S300-97	50	22' 0"	20' 0"	17' 5"	24' 8"	22' 5"	19' 7"	20' 0"	18' 2"	15' 10"	22' 5"	20' 4"	17' 9"
800S137-33	33	13' 1" e	11' 4" e	9' 3" e	13' 1" a	10' 9" a	8' 0" a	13' 1" e	11' 4" e	9' 3" e	13' 1" a	10' 9" a	8' 0" a
800S137-43	33	15' 10"	13' 9"	11' 3" e	15' 10" i	13' 9" i	11' 3" i	15' 10"	13' 9"	11' 3" e	15' 10" i	13' 9" i	11' 3" i
800S137-54	50	19' 4"	17' 7"	15' 0"	21' 3" i	18' 5" i	15' 0" i	17' 7"	16' 0"	13' 11"	19' 9" i	17' 11" i	15' 0" i
800S137-68	50	20' 11"	19' 0"	16' 7"	23' 6" i	21' 4" i	17' 8" i	19' 0"	17' 3"	15' 1"	21' 4"	19' 5"	16' 11" i
800S137-97	50	23' 3"	21' 1"	18' 5"	26' 1"	23' 8"	20' 8"	21' 1"	19' 2"	16' 9"	23' 8"	21' 6"	18' 10"
800S162-33	33	14' 3" e	12' 4" e	10' 1" e	13' 10" a	11' 4" a	8' 4" a	14' 3" e	12' 4" e	10' 1" e	13' 10" a	11' 4" a	8' 4" a
800S162-43	33	17' 2"	14' 11" e	12' 2" e	17' 2" i	14' 11" i	12' 2" a	17' 2"	14' 11" e	12' 2" e	17' 2" i	14' 11" i	12' 2" a
800S162-54	50	20' 2"	18' 3"	16' 0"	22' 7" i	19' 10" i	16' 2" i	18' 3"	16' 7"	14' 6"	20' 6" i	18' 8" i	16' 2" i
800S162-68	50	21' 9"	19' 9"	17' 3"	24' 5"	22' 2" i	19' 0" i	19' 9"	18' 0"	15' 8"	22' 2" i	20' 2" i	17' 7" i
800S162-97	50	24' 2"	22' 0"	19' 2"	27' 2"	24' 8"	21' 7"	22' 0"	20' 0"	17' 5"	24' 8"	22' 5"	19' 7"
800S200-33	33	15' 4" e	13' 4" e	10' 10" e	14' 6" a	11' 9" a	8' 8" a	15' 4" e	13' 4" e	10' 10" e	14' 6" a	11' 9" a	8' 8" a
800S200-43	33	18' 5"	16' 0" e	13' 1" e	18' 5" i	16' 0" i	13' 1" a	18' 0"	16' 0" e	13' 1" e	18' 5" i	16' 0" i	13' 1" a
800S200-54	50	21' 3"	19' 4"	16' 10"	23' 10" i	21' 3" i	17' 4" i	19' 4"	17' 6"	15' 4"	21' 8" i	19' 8" i	17' 2" i
800S200-68	50	22' 10"	20' 9"	18' 1"	25' 7"	23' 3" i	20' 3" i	20' 9"	18' 10"	16' 5"	23' 3" i	21' 2"	18' 6" i
800S200-97	50	25' 4"	23' 1"	20' 2"	28' 6"	25' 11"	22' 7"	23' 1"	20' 11"	18' 4"	25' 11"	23' 6"	20' 6"
800S250-43	33	18' 11"	16' 5" e	13' 5" e	18' 11" i	16' 5" i	13' 5" a	18' 9"	16' 5" e	13' 5" e	18' 11" i	16' 5" i	13' 5" a
800S250-54	50	22' 1"	20' 1"	17' 6"	24' 9" i	21' 9" i	17' 9" i	20' 1"	18' 3"	15' 11"	22' 6" i	20' 5" i	17' 9" i
800S250-68	50	23' 9"	21' 7"	18' 11"	26' 9"	24' 3" i	20' 10" i	21' 7"	19' 8"	17' 2"	24' 3" i	22' 1" i	19' 3" i
800S250-97	50	26' 6"	24' 1"	21' 1"	29' 9"	27' 1"	23' 7"	24' 1"	21' 11"	19' 1"	27' 1"	24' 7"	21' 6"
800S300-54	50	22' 7"	20' 6"	17' 11"	25' 4" i	22' 1" i	18' 0" i	20' 6"	18' 7"	16' 3"	23' 0" i	20' 11" i	18' 0" i
800S300-68	50	24' 6"	22' 3"	19' 5"	27' 6" i	25' 0" i	21' 2" i	22' 3"	20' 3"	17' 8"	25' 0" i	22' 8" i	19' 10" i
800S300-97	50	27' 5"	24' 11"	21' 9"	30' 10"	28' 0"	24' 5"	24' 11"	22' 8"	19' 9"	28' 0"	25' 5"	22' 3"

Notes:

- 1 Web punchouts are not considered for shear and web crippling.
- 2 Deflection checks are computed using unbalanced loads for the two equal span conditions.
- 3 "e" indicates that the web stiffeners are required at the end support only.
- 4 "i" indicates that the web stiffeners are required at the interior support only.
- 5 "a" indicates that the web stiffeners are required at all supports.
- 6 See additional floor joist notes on page 62.

Complies with AISI S100-16 (2020) w/S2-20 • IBC 2024

FLOOR JOIST SPAN LIMITATIONS

10psf Dead Load and 30psf Live Load (TL Deflection=L/240)

Member	Yield strength F _y (ksi)	Live Load Deflection L/360						Live Load Deflection L/480					
		Single span spacing (in) o.c.			Two equal span spacing (in) o.c.			Single span spacing (in) o.c.			Two equal span spacing (in) o.c.		
		12	16	24	12	16	24	12	16	24	12	16	24
1000S162-43	33	19' 1" e	16' 6" e	13' 6" e	19' 1" a	16' 6" a	12' 9" a	19' 1" e	16' 6" e	13' 6" e	19' 1" a	16' 6" a	12' 9" a
1000S162-54	50	23' 11"	21' 9"	18' 0"	25' 6" i	22' 1" i	18' 0" i	21' 9"	19' 9"	17' 3"	24' 5" i	22' 1" i	18' 0" i
1000S162-68	50	25' 11"	23' 7"	20' 7"	29' 1" i	26' 0" i	21' 3" i	23' 7"	21' 5"	18' 8"	26' 6"	24' 0" i	21' 0" i
1000S162-97	50	29' 2"	26' 6"	23' 1"	32' 8"	29' 9"	26' 0" i	26' 6"	24' 1"	21' 0"	29' 9"	27' 0"	23' 7"
1000S200-43	33	20' 7" e	17' 10" e	14' 7" e	20' 7" a	17' 9" a	13' 4" a	20' 7" e	17' 10" e	14' 7" e	20' 7" a	17' 9" a	13' 4" a
1000S200-54	50	25' 0"	22' 9"	19' 5"	27' 6" i	23' 9" i	19' 5" i	22' 9"	20' 8"	18' 1"	25' 6" i	23' 2" i	19' 5" i
1000S200-68	50	27' 1"	24' 7"	21' 6"	30' 5" i	27' 8" i	22' 10" i	24' 7"	22' 4"	19' 7"	27' 8"	25' 1" i	21' 11" i
1000S200-97	50	30' 5"	27' 8"	24' 2"	34' 2"	31' 0"	27' 1" i	27' 8"	25' 1"	21' 11"	31' 0"	28' 2"	24' 8"
1000S250-54	50	26' 5"	24' 0"	19' 11"	28' 3" i	24' 5" i	19' 11" i	24' 0"	21' 10"	19' 1"	26' 11" i	24' 5" i	19' 11" i
1000S250-68	50	28' 5"	25' 10"	22' 7"	31' 11" i	28' 9" i	23' 6" i	25' 10"	23' 5"	20' 6"	29' 0"	26' 4" i	23' 0" i
1000S250-97	50	31' 8"	28' 9"	25' 2"	35' 7"	32' 4"	28' 3" i	28' 9"	26' 2"	22' 10"	32' 4"	29' 4"	25' 8"
1000S300-54	50	26' 11"	24' 6"	20' 3"	28' 8" i	24' 10" i	20' 3" i	24' 6"	22' 3"	19' 5"	27' 6" i	24' 10" i	20' 3" i
1000S300-68	50	29' 2"	26' 6"	23' 2"	32' 9" i	29' 3" i	23' 10" i	26' 6"	24' 1"	21' 1"	29' 9" i	27' 1" i	23' 8" i
1000S300-97	50	32' 8"	29' 8"	25' 11"	36' 8"	33' 4"	29' 2" i	29' 8"	27' 0"	23' 7"	33' 4"	30' 4"	26' 6"
1200S162-54	50	27' 5" e	23' 9" e	19' 5" e	27' 5" a	23' 9" a	19' 4" a	25' 0" e	22' 9" e	19' 5" e	27' 5" a	23' 9" a	19' 4" a
1200S162-68	50	29' 11"	27' 2"	23' 0"	32' 7" i	28' 3" i	23' 0" i	27' 2"	24' 8"	21' 7"	30' 6" i	27' 9" i	23' 0" i
1200S162-97	50	33' 11"	30' 10"	26' 11"	38' 1"	34' 7" i	29' 10" i	30' 10"	28' 0"	24' 5"	34' 7"	31' 5"	27' 5" i
1200S200-54	50	28' 9" e	25' 10" e	21' 1" e	29' 10" a	25' 10" a	20' 4" a	26' 2" e	23' 9" e	20' 9" e	29' 4" a	25' 10" a	20' 4" a
1200S200-68	50	31' 2"	28' 4"	24' 9"	35' 0" i	30' 6" i	24' 11" i	28' 4"	25' 9"	22' 6"	31' 10" i	28' 11" i	24' 11" i
1200S200-97	50	35' 4"	32' 1"	28' 0"	39' 8"	36' 0" i	31' 5" i	32' 1"	29' 2"	25' 5"	36' 0"	32' 9"	28' 7" i
1200S250-54	50	29' 11" e	26' 8" e	21' 9" e	30' 10" a	26' 8" a	20' 9" a	27' 3" e	24' 9" e	21' 7" e	30' 7" a	26' 8" a	20' 9" a
1200S250-68	50	32' 6"	29' 6"	25' 9"	36' 4" i	31' 6" i	25' 9" i	29' 6"	26' 10"	23' 5"	33' 2" i	30' 2" i	25' 9" i
1200S250-97	50	36' 8"	33' 4"	29' 1"	41' 2"	37' 5" i	32' 8" i	33' 4"	30' 3"	26' 5"	37' 5"	34' 0"	29' 8" i
1200S300-54	50	31' 4" e	27' 2" e	22' 2" e	31' 5" a	27' 2" a	21' 0" a	28' 5" e	25' 10" e	22' 2" e	31' 5" a	27' 2" a	21' 0" a
1200S300-68	50	33' 10"	30' 9"	26' 3"	37' 1" i	32' 1" i	26' 3" i	30' 9"	27' 11"	24' 5"	34' 6" i	31' 4" i	26' 3" i
1200S300-97	50	37' 10"	34' 4"	30' 0"	42' 5"	38' 7" i	33' 8" i	34' 4"	31' 2"	27' 3"	38' 7"	35' 0"	30' 7" i
1400S162-54	50	29' 0" e	25' 1" e	20' 6" e	29' 0" a	24' 11" a	18' 9" a	28' 2" e	25' 1" e	20' 6" e	29' 0" a	24' 11" a	18' 9" a
1400S162-68	50	33' 9"	30' 0"	24' 6"	34' 7" i	30' 0" i	24' 6" i	30' 8"	27' 10"	24' 4"	34' 5" i	30' 0" i	24' 6" i
1400S162-97	50	38' 5"	34' 11"	30' 6"	43' 2" i	39' 1" i	31' 11" i	34' 11"	31' 8"	27' 8"	39' 2"	35' 7"	31' 1" i
1400S200-54	50	31' 8" e	27' 5" e	22' 5" e	31' 8" a	26' 4" a	19' 8" a	29' 5" e	26' 8" e	22' 5" e	31' 8" a	26' 4" a	19' 8" a
1400S200-68	50	35' 2"	31' 11"	26' 7"	37' 7" i	32' 7" i	26' 7" i	31' 11"	29' 0"	25' 4"	35' 10" i	32' 7" i	26' 7" i
1400S200-97	50	39' 11"	36' 3"	31' 8"	44' 10"	40' 8" i	34' 5" i	36' 3"	32' 11"	28' 9"	40' 8"	37' 0"	32' 4" i
1400S250-54	50	32' 11" e	28' 6" e	23' 3" e	32' 11" a	26' 11" a	20' 1" a	30' 7" e	27' 9" e	23' 3" e	32' 11" a	26' 11" a	20' 1" a
1400S250-68	50	36' 7"	33' 3"	27' 7"	39' 0" i	33' 10" i	27' 7" i	33' 3"	30' 2"	26' 4"	37' 4" i	33' 10" i	27' 7" i
1400S250-97	50	41' 5"	37' 7"	32' 10"	46' 6"	42' 3" i	35' 9" i	37' 7"	34' 2"	29' 10"	42' 3"	38' 4"	33' 6" i
1400S300-54	50	33' 9" e	29' 2" e	23' 10" e	33' 5" a	27' 4" a	20' 4" a	31' 0" e	28' 2" e	23' 10" e	33' 5" a	27' 4" a	20' 4" a
1400S300-68	50	37' 6"	34' 1"	28' 3"	39' 11" i	34' 7" i	28' 3" i	34' 1"	31' 0"	27' 1"	38' 3" i	34' 7" i	28' 3" i
1400S300-97	50	42' 8"	38' 9"	33' 10"	47' 11" i	43' 6" i	36' 7" i	38' 9"	35' 2"	30' 9"	43' 6"	39' 6"	34' 6" i

Notes:

- 1 Web punchouts are not considered for shear and web crippling.
- 2 Deflection checks are computed using unbalanced loads for the two equal span conditions.
- 3 "e" indicates that the web stiffeners are required at the end support only.
- 4 "i" indicates that the web stiffeners are required at the interior support only.
- 5 "a" indicates that the web stiffeners are required at all supports.
- 6 See additional floor joist notes on page 62.

Complies with AISI S100-16 (2020) w/S20-20 • IBC 2024

The technical content of this literature is effective 06/01/24 and supersedes all previous information.

FLOOR JOIST SPAN LIMITATIONS

10psf Dead Load and 40psf Live Load (TL Deflection=L/240)

Member	Yield strength F _y (ksi)	Live Load Deflection L/360						Live Load Deflection L/480					
		Single span spacing (in) o.c.			Two equal span spacing (in) o.c.			Single span spacing (in) o.c.			Two equal span spacing (in) o.c.		
		12	16	24	12	16	24	12	16	24	12	16	24
600S137-33	33	10' 2" e	8' 10" e	7' 3" e	10' 2" i	8' 10" a	7' 2" a	10' 2" e	8' 10" e	7' 3" e	10' 2" i	8' 10" a	7' 2" a
600S137-43	33	12' 3"	10' 7"	8' 8" e	12' 3" i	10' 7" i	8' 8" i	11' 10"	10' 7"	8' 8" e	12' 3" i	10' 7" i	8' 8" i
600S137-54	50	14' 0"	12' 9"	11' 1"	15' 9" i	14' 2" i	11' 7" i	12' 9"	11' 7"	10' 1"	14' 4"	13' 0" i	11' 4" i
600S137-68	50	15' 0"	13' 8"	11' 11"	16' 10"	15' 4" i	13' 4" i	13' 8"	12' 5"	10' 10"	15' 4"	13' 11"	12' 2" i
600S137-97	50	16' 7"	15' 1"	13' 2"	18' 8"	16' 11"	14' 10"	15' 1"	13' 8"	12' 0"	16' 11"	15' 5"	13' 5"
600S162-33	33	11' 0" e	9' 7" e	7' 10" e	11' 0" i	9' 7" a	7' 6" a	11' 0" e	9' 7" e	7' 10" e	11' 0" i	9' 7" a	7' 6" a
600S162-43	33	13' 2"	11' 5"	9' 4" e	13' 2" i	11' 5" i	9' 4" i	12' 5"	11' 3"	9' 4" e	13' 2" i	11' 5" i	9' 4" i
600S162-54	50	14' 7"	13' 3"	11' 7"	16' 5" i	14' 11" i	12' 5" i	13' 3"	12' 1"	10' 7"	14' 11"	13' 7" i	11' 10" i
600S162-68	50	15' 8"	14' 3"	12' 5"	17' 7"	16' 0"	14' 0" i	14' 3"	12' 11"	11' 4"	16' 0"	14' 6"	12' 8" i
600S162-97	50	17' 4"	15' 9"	13' 9"	19' 6"	17' 9"	15' 6"	15' 9"	14' 4"	12' 6"	17' 9"	16' 1"	14' 1"
600S200-33	33	11' 10" e	10' 3" e	8' 4" e	11' 10" a	10' 3" a	7' 10" a	11' 10" e	10' 3" e	8' 4" e	11' 10" a	10' 3" a	7' 10" a
600S200-43	33	14' 1"	12' 3" e	10' 0" e	14' 1" i	12' 3" i	10' 0" a	13' 0"	11' 10"	10' 0" e	14' 1" i	12' 3" i	10' 0" a
600S200-54	50	15' 4"	14' 0"	12' 2"	17' 3" i	15' 8" i	13' 3" i	14' 0"	12' 8"	11' 1"	15' 8"	14' 3" i	12' 5" i
600S200-68	50	16' 6"	15' 0"	13' 1"	18' 6"	16' 10"	14' 8" i	15' 0"	13' 7"	11' 11"	16' 10"	15' 3"	13' 4" i
600S200-97	50	18' 4"	16' 8"	14' 6"	20' 7"	18' 8"	16' 4"	16' 8"	15' 1"	13' 2"	18' 8"	17' 0"	14' 10"
600S250-43	33	14' 6"	12' 7" e	10' 3" e	14' 6" i	12' 7" i	10' 3" a	13' 7"	12' 4" e	10' 3" e	14' 6" i	12' 7" i	10' 3" a
600S250-54	50	16' 0"	14' 7"	12' 9"	18' 0" i	16' 4" i	13' 7" i	14' 7"	13' 3"	11' 7"	16' 4"	14' 10" i	13' 0" i
600S250-68	50	17' 3"	15' 8"	13' 9"	19' 5"	17' 8" i	15' 5" i	15' 8"	14' 3"	12' 6"	17' 8"	16' 0"	14' 0" i
600S250-97	50	19' 3"	17' 6"	15' 3"	21' 7"	19' 7"	17' 2"	17' 6"	15' 10"	13' 10"	19' 7"	17' 10"	15' 7"
600S300-54	50	16' 4"	14' 10"	13' 0"	18' 5" i	16' 8" i	13' 10" i	14' 10"	13' 6"	11' 10"	16' 8"	15' 2" i	13' 3" i
600S300-68	50	17' 10"	16' 3"	14' 2"	20' 1"	18' 3" i	15' 11" i	16' 3"	14' 9"	12' 11"	18' 3"	16' 7"	14' 6" i
600S300-97	50	20' 0"	18' 2"	15' 10"	22' 5"	20' 4"	17' 9"	18' 2"	16' 6"	14' 5"	20' 4"	18' 6"	16' 2"
800S137-33	33	11' 9" e	10' 2" e	8' 3" e	11' 3" a	9' 2" a	6' 9" a	11' 9" e	10' 2" e	8' 3" e	11' 3" a	9' 2" a	6' 9" a
800S137-43	33	14' 2"	12' 3" e	10' 0" e	14' 2" i	12' 3" i	10' 0" a	14' 2"	12' 3" e	10' 0" e	14' 2" i	12' 3" i	10' 0" a
800S137-54	50	17' 7"	16' 0"	13' 5"	19' 0" i	16' 5" i	13' 5" i	16' 0"	14' 6"	12' 8"	17' 11" i	16' 4" i	13' 5" i
800S137-68	50	19' 0"	17' 3"	15' 1"	21' 4" i	19' 4" i	15' 9" i	17' 3"	15' 8"	13' 8"	19' 5"	17' 7" i	15' 5" i
800S137-97	50	21' 1"	19' 2"	16' 9"	23' 8"	21' 6"	18' 10" i	19' 2"	17' 5"	15' 3"	21' 6"	19' 7"	17' 1"
800S162-33	33	12' 9" e	11' 1" e	9' 0" e	11' 10" a	9' 7" a	7' 0" a	12' 9" e	11' 1" e	9' 0" e	11' 10" a	9' 7" a	7' 0" a
800S162-43	33	15' 4" e	13' 4" e	10' 10" e	15' 4" i	13' 4" i	10' 10" a	15' 4" e	13' 4" e	10' 10" e	15' 4" i	13' 4" i	10' 10" a
800S162-54	50	18' 3"	16' 7"	14' 6"	20' 6" i	17' 9" i	14' 6" i	16' 7"	15' 1"	13' 2"	18' 8" i	16' 11" i	14' 6" i
800S162-68	50	19' 9"	18' 0"	15' 8"	22' 2" i	20' 2" i	17' 0" i	18' 0"	16' 4"	14' 3"	20' 2"	18' 4" i	16' 0" i
800S162-97	50	22' 0"	20' 0"	17' 5"	24' 8"	22' 5"	19' 7"	20' 0"	18' 2"	15' 10"	22' 5"	20' 4"	17' 10"

Notes:

- 1 Web punchouts are not considered for shear and web crippling.
- 2 Deflection checks are computed using unbalanced loads for the two equal span conditions.
- 3 "e" indicates that the web stiffeners are required at the end support only.
- 4 "i" indicates that the web stiffeners are required at the interior support only.
- 5 "a" indicates that the web stiffeners are required at all supports.
- 6 See additional floor joist notes on page 62.

Complies with AISI S100-16 (2020) w/S2-20 • IBC 2024

FLOOR JOIST SPAN LIMITATIONS

10psf Dead Load and 40psf Live Load (TL Deflection=L/240)

Member	Yield strength F _y (ksi)	Live Load Deflection L/360						Live Load Deflection L/480					
		Single span spacing (in) o.c.			Two equal span spacing (in) o.c.			Single span spacing (in) o.c.			Two equal span spacing (in) o.c.		
		12	16	24	12	16	24	12	16	24	12	16	24
800S200-33	33	13' 9" e	11' 11" e	9' 6" e	12' 4" a	9' 11" a	7' 3" a	13' 9" e	11' 11" e	9' 6" e	12' 4" a	9' 11" a	7' 3" a
800S200-43	33	16' 6" e	14' 3" e	11' 8" e	16' 6" i	14' 3" a	11' 8" a	16' 4" e	14' 3" e	11' 8" e	16' 6" i	14' 3" a	11' 8" a
800S200-54	50	19' 4"	17' 6"	15' 4"	21' 8" i	19' 0" i	15' 6" i	17' 6"	15' 11"	13' 11"	19' 8" i	17' 11" i	15' 6" i
800S200-68	50	20' 9"	18' 10"	16' 5"	23' 3" i	21' 2" i	18' 2" i	18' 10"	17' 1"	14' 11"	21' 2"	19' 2" i	16' 9" i
800S200-97	50	23' 1"	20' 11"	18' 4"	25' 11"	23' 6"	20' 6"	20' 11"	19' 0"	16' 7"	23' 6"	21' 4"	18' 8"
800S250-43	33	16' 11" e	14' 8" e	12' 0" e	16' 11" i	14' 8" a	11' 11" a	16' 11" e	14' 8" e	12' 0" e	16' 11" i	14' 8" a	11' 11" a
800S250-54	50	20' 1"	18' 3"	15' 11"	22' 6" i	19' 6" i	15' 11" i	18' 3"	16' 7"	14' 6"	20' 5" i	18' 7" i	15' 11" i
800S250-68	50	21' 7"	19' 8"	17' 2"	24' 3" i	22' 1" i	18' 7" i	19' 8"	17' 10"	15' 7"	22' 1"	20' 0" i	17' 6" i
800S250-97	50	24' 1"	21' 11"	19' 1"	27' 1"	24' 7"	21' 6" i	21' 11"	19' 11"	17' 4"	24' 7"	22' 4"	19' 6"
800S300-54	50	20' 6"	18' 7"	16' 2"	22' 10" i	19' 9" i	16' 2" i	18' 7"	16' 11"	14' 9"	20' 11" i	19' 0" i	16' 2" i
800S300-68	50	22' 3"	20' 3"	17' 8"	25' 0" i	22' 8" i	18' 11" i	20' 3"	18' 4"	16' 1"	22' 8"	20' 7" i	18' 0" i
800S300-97	50	24' 11"	22' 8"	19' 9"	28' 0"	25' 5"	22' 3" i	22' 8"	20' 7"	18' 0"	25' 5"	23' 1"	20' 2"
1000S162-43	33	17' 1" e	14' 9" e	12' 1" e	17' 1" a	14' 6" a	10' 10" a	17' 1" e	14' 9" e	12' 1" e	17' 1" a	14' 6" a	10' 10" a
1000S162-54	50	21' 9"	19' 9"	16' 1"	22' 9" i	19' 9" i	16' 1" i	19' 9"	17' 11"	15' 8"	22' 2" i	19' 9" i	16' 1" i
1000S162-68	50	23' 7"	21' 5"	18' 8"	26' 6" i	23' 3" i	19' 0" i	21' 5"	19' 5"	17' 0"	24' 0" i	21' 10" i	19' 0" i
1000S162-97	50	26' 6"	24' 1"	21' 0"	29' 9"	27' 0"	23' 7" i	24' 1"	21' 10"	19' 1"	27' 0"	24' 6"	21' 5"
1000S200-43	33	18' 5" e	16' 0" e	13' 0" e	18' 5" a	15' 2" a	11' 3" a	18' 5" e	16' 0" e	13' 0" e	18' 5" a	15' 2" a	11' 3" a
1000S200-54	50	22' 9"	20' 8"	17' 4" e	24' 7" i	21' 3" i	17' 4" i	20' 8"	18' 9"	16' 5"	23' 2" i	21' 1" i	17' 4" i
1000S200-68	50	24' 7"	22' 4"	19' 7"	27' 8" i	25' 0" i	20' 5" i	22' 4"	20' 4"	17' 9"	25' 1" i	22' 10" i	19' 11" i
1000S200-97	50	27' 8"	25' 1"	21' 11"	31' 0"	28' 2"	24' 8" i	25' 1"	22' 10"	19' 11"	28' 2"	25' 7"	22' 5"
1000S250-54	50	24' 0"	21' 10"	17' 10" e	25' 3" i	21' 10" i	17' 10" i	21' 10"	19' 10"	17' 4" e	24' 6" i	21' 10" i	17' 10" i
1000S250-68	50	25' 10"	23' 5"	20' 6"	29' 0" i	25' 8" i	21' 0" i	23' 5"	21' 4"	18' 7"	26' 4" i	23' 11" i	20' 11" i
1000S250-97	50	28' 9"	26' 2"	22' 10"	32' 4"	29' 4"	25' 8" i	26' 2"	23' 9"	20' 9"	29' 4"	26' 8"	23' 4" i
1000S300-54	50	24' 6"	22' 3"	18' 2" e	25' 8" i	22' 3" i	18' 2" i	22' 3"	20' 3"	17' 8" e	25' 0" i	22' 3" i	18' 2" i
1000S300-68	50	26' 6"	24' 1"	21' 1"	29' 9"	26' 2" i	21' 4" i	24' 1"	21' 11"	19' 2"	27' 1" i	24' 7" i	21' 4" i
1000S300-97	50	29' 8"	27' 0"	23' 7"	33' 4"	30' 4"	26' 6" i	27' 0"	24' 6"	21' 5"	30' 4"	27' 6"	24' 1" i
1200S162-54	50	24' 7" e	21' 3" e	17' 4" e	24' 7" a	21' 3" a	16' 7" a	22' 9" e	20' 8" e	17' 4" e	24' 7" a	21' 3" a	16' 7" a
1200S162-68	50	27' 2"	24' 8"	20' 7"	29' 2" i	25' 3" i	20' 7" i	24' 8"	22' 5"	19' 7"	27' 9" i	25' 2" i	20' 7" i
1200S162-97	50	30' 10"	28' 0"	24' 5"	34' 7"	31' 5" i	26' 8" i	28' 0"	25' 5"	22' 3"	31' 5"	28' 7"	24' 11" i
1200S200-54	50	26' 2" e	23' 1" e	18' 10" e	26' 8" a	23' 1" a	17' 4" a	23' 9" e	21' 7" e	18' 10" e	26' 8" a	23' 1" a	17' 4" a
1200S200-68	50	28' 4"	25' 9"	22' 3"	31' 6" i	27' 3" i	22' 3" i	25' 9"	23' 5"	20' 5"	28' 11" i	26' 3" i	22' 3" i
1200S200-97	50	32' 1"	29' 2"	25' 5"	36' 0"	32' 9" i	28' 7" i	29' 2"	26' 6"	23' 1"	32' 9"	29' 9"	26' 0" i

Notes:

- 1 Web punchouts are not considered for shear and web crippling.
- 2 Deflection checks are computed using unbalanced loads for the two equal span conditions.
- 3 "e" indicates that the web stiffeners are required at the end support only.
- 4 "i" indicates that the web stiffeners are required at the interior support only.
- 5 "a" indicates that the web stiffeners are required at all supports.
- 6 See additional floor joist notes on page 62.

Complies with AISI S100-16 (2020) w/S20-2 • IBC 2024

FLOOR JOIST SPAN LIMITATIONS

10psf Dead Load and 40psf Live Load (TL Deflection=L/240)

Member	Yield strength F _y (ksi)	Live Load Deflection L/360						Live Load Deflection L/480					
		Single span spacing (in) o.c.			Two equal span spacing (in) o.c.			Single span spacing (in) o.c.			Two equal span spacing (in) o.c.		
		12	16	24	12	16	24	12	16	24	12	16	24
1200S250-54	50	27' 3" e	23' 10" e	19' 6" e	27' 7" a	23' 7" a	17' 8" a	24' 9" e	22' 6" e	19' 6" e	27' 7" a	23' 7" a	17' 8" a
1200S250-68	50	29' 6"	26' 10"	23' 0"	32' 6" i	28' 2" i	23' 0" i	26' 10"	24' 5"	21' 4"	30' 2" i	27' 4" i	23' 0" i
1200S250-97	50	33' 4"	30' 3"	26' 5"	37' 5"	34' 0" i	29' 7" i	30' 3"	27' 6"	24' 0"	34' 0"	30' 11"	27' 0" i
1200S300-54	50	28' 1" e	24' 4" e	19' 10" e	28' 1" a	23' 10" a	17' 11" a	25' 10" e	23' 6" e	19' 10" e	28' 1" a	23' 10" a	17' 11" a
1200S300-68	50	30' 9"	27' 11"	23' 5"	33' 2" i	28' 9" i	23' 5" i	27' 11"	25' 4"	22' 2"	31' 4" i	28' 6" i	23' 5" i
1200S300-97	50	34' 4"	31' 2"	27' 3"	38' 7"	35' 0" i	30' 2" i	31' 2"	28' 4"	24' 9"	35' 0"	31' 10"	27' 10" i
1400S162-54	50	25' 11" e	22' 6" e	18' 4" e	25' 11" a	21' 4" a	15' 11" a	25' 7" e	22' 6" e	18' 4" e	25' 11" a	21' 4" a	15' 11" a
1400S162-68	50	30' 8"	26' 10"	21' 11"	31' 0" i	26' 10" i	21' 11" i	27' 10"	25' 4"	21' 11"	31' 0" i	26' 10" i	21' 11" i
1400S162-97	50	34' 11"	31' 8"	27' 8"	39' 2" i	35' 0" i	28' 7" i	31' 8"	28' 10"	25' 2"	35' 7"	32' 4" i	28' 3" i
1400S200-54	50	28' 4" e	24' 6" e	20' 0" e	27' 6" a	22' 5" a	16' 8" a	26' 8" e	24' 3" e	20' 0" e	27' 6" a	22' 5" a	16' 8" a
1400S200-68	50	31' 11"	29' 0"	23' 9"	33' 7" i	29' 1" i	23' 9" i	29' 0"	26' 4"	23' 0"	32' 7" i	29' 1" i	23' 9" i
1400S200-97	50	36' 3"	32' 11"	28' 9"	40' 8" i	37' 0" i	30' 10" i	32' 11"	29' 11"	26' 2"	37' 0"	33' 7" i	29' 4" i
1400S250-54	50	29' 5" e	25' 6" e	20' 10" e	28' 2" a	23' 0" a	16' 11" a	27' 9" e	25' 3" e	20' 10" e	28' 2" a	23' 0" a	16' 11" a
1400S250-68	50	33' 3"	30' 2"	24' 8" e	34' 11" i	30' 3" i	24' 8" i	30' 2"	27' 5"	24' 0"	33' 11" i	30' 3" i	24' 8" i
1400S250-97	50	37' 7"	34' 2"	29' 10"	42' 3" i	38' 4" i	32' 0" i	34' 2"	31' 0"	27' 1"	38' 4"	34' 10" i	30' 5" i
1400S300-54	50	30' 2" e	26' 1" e	21' 4" e	28' 7" a	23' 3" a	17' 2" a	28' 2" e	25' 7" e	21' 4" e	28' 7" a	23' 3" a	17' 2" a
1400S300-68	50	34' 1"	30' 11"	25' 3" e	35' 9" i	30' 11" i	25' 3" i	31' 0"	28' 2"	24' 7" e	34' 9" i	30' 11" i	25' 3" i
1400S300-97	50	38' 9"	35' 2"	30' 9"	43' 6" i	39' 6" i	32' 9" i	35' 2"	32' 0"	27' 11"	39' 6"	35' 11" i	31' 4" i

Notes:

- 1 Web punchouts are not considered for shear and web crippling.
- 2 Deflection checks are computed using unbalanced loads for the two equal span conditions.
- 3 "e" indicates that the web stiffeners are required at the end support only.
- 4 "i" indicates that the web stiffeners are required at the interior support only.
- 5 "a" indicates that the web stiffeners are required at all supports.
- 6 See additional floor joist notes on page 62.

Complies with AISI S100-16 (2020) w/S2-20 • IBC 2024

The technical content of this literature is effective 06/01/24 and supersedes all previous information.

FLOOR JOIST SPAN LIMITATIONS

10psf Dead Load and 50psf Live Load (TL Deflection=L/240)

Member	Yield strength F _y (ksi)	Live Load Deflection L/360						Live Load Deflection L/480					
		Single span spacing (in) o.c.			Two equal span spacing (in) o.c.			Single span spacing (in) o.c.			Two equal span spacing (in) o.c.		
		12	16	24	12	16	24	12	16	24	12	16	24
600S137-33	33	9' 4" e	8' 1" e	6' 7" e	9' 4" i	8' 1" a	6' 4" a	9' 4" e	8' 1" e	6' 7" e	9' 4" i	8' 1" a	6' 4" a
600S137-43	33	11' 2"	9' 8"	7' 11" e	11' 2" i	9' 8" i	7' 11" a	11' 0"	9' 8"	7' 11" e	11' 2" i	9' 8" i	7' 11" a
600S137-54	50	13' 0"	11' 10"	10' 4"	14' 7" i	12' 11" i	10' 7" i	11' 10"	10' 9"	9' 5"	13' 3" i	12' 1" i	10' 6" i
600S137-68	50	13' 11"	12' 8"	11' 1"	15' 8"	14' 3" i	12' 4" i	12' 8"	11' 6"	10' 1"	14' 3"	12' 11"	11' 3" i
600S137-97	50	15' 5"	14' 0"	12' 3"	17' 4"	15' 9"	13' 9"	14' 0"	12' 9"	11' 1"	15' 9"	14' 3"	12' 6"
600S162-33	33	10' 1" e	8' 9" e	7' 1" e	10' 1" a	8' 9" a	6' 7" a	10' 1" e	8' 9" e	7' 1" e	10' 1" a	8' 9" a	6' 7" a
600S162-43	33	12' 1"	10' 5" e	8' 6" e	12' 1" i	10' 5" i	8' 6" a	11' 6"	10' 5" e	8' 6" e	12' 1" i	10' 5" i	8' 6" a
600S162-54	50	13' 7"	12' 4"	10' 9"	15' 3" i	13' 10" i	11' 4" i	12' 4"	11' 2"	9' 9"	13' 10"	12' 7" i	11' 0" i
600S162-68	50	14' 7"	13' 3"	11' 7"	16' 4"	14' 10" i	13' 0" i	13' 3"	12' 0"	10' 6"	14' 10"	13' 6"	11' 9" i
600S162-97	50	16' 2"	14' 8"	12' 10"	18' 1"	16' 5"	14' 4"	14' 8"	13' 4"	11' 8"	16' 5"	14' 11"	13' 1"
600S200-33	33	10' 9" e	9' 4" e	7' 7" e	10' 9" a	9' 2" a	6' 10" a	10' 9" e	9' 4" e	7' 7" e	10' 9" a	9' 2" a	6' 10" a
600S200-43	33	12' 11"	11' 2" e	9' 1" e	12' 11" i	11' 2" i	9' 1" a	12' 1"	11' 0" e	9' 1" e	12' 11" i	11' 2" i	9' 1" a
600S200-54	50	14' 3"	13' 0"	11' 4"	16' 0" i	14' 7" i	12' 1" i	13' 0"	11' 9"	10' 3"	14' 7" i	13' 3" i	11' 7" i
600S200-68	50	15' 4"	13' 11"	12' 2"	17' 2"	15' 7" i	13' 8" i	13' 11"	12' 8"	11' 0"	15' 7"	14' 2"	12' 5" i
600S200-97	50	17' 0"	15' 5"	13' 6"	19' 1"	17' 4"	15' 2"	15' 5"	14' 0"	12' 3"	17' 4"	15' 9"	13' 9"
600S250-43	33	13' 3"	11' 5" e	9' 4" e	13' 3" i	11' 5" i	9' 4" a	12' 8"	11' 5" e	9' 4" e	13' 3" i	11' 5" i	9' 4" a
600S250-54	50	14' 11"	13' 6"	11' 10"	16' 8" i	15' 2" i	12' 5" i	13' 6"	12' 3"	10' 9"	15' 2" i	13' 9" i	12' 1" i
600S250-68	50	16' 1"	14' 7"	12' 9"	18' 0"	16' 4" i	14' 4" i	14' 7"	13' 3"	11' 7"	16' 4"	14' 10"	13' 0" i
600S250-97	50	17' 10"	16' 3"	14' 2"	20' 0"	18' 2"	15' 11"	16' 3"	14' 9"	12' 10"	18' 2"	16' 6"	14' 5"
600S300-54	50	15' 2"	13' 10"	12' 1"	17' 1" i	15' 6" i	12' 7" i	13' 10"	12' 7"	10' 11"	15' 6" i	14' 1" i	12' 4" i
600S300-68	50	16' 7"	15' 1"	13' 2"	18' 7"	16' 11" i	14' 9" i	15' 1"	13' 8"	12' 0"	16' 11"	15' 4"	13' 5" i
600S300-97	50	18' 6"	16' 10"	14' 9"	20' 10"	18' 11"	16' 6"	16' 10"	15' 4"	13' 4"	18' 11"	17' 2"	15' 0"
800S137-33	33	10' 8" e	9' 3" e	7' 7" e	9' 11" a	8' 0" a	5' 11" a	10' 8" e	9' 3" e	7' 7" e	9' 11" a	8' 0" a	5' 11" a
800S137-43	33	12' 11" e	11' 3" e	9' 2" e	12' 11" i	11' 3" a	9' 2" a	12' 11" e	11' 3" e	9' 2" e	12' 11" i	11' 3" a	9' 2" a
800S137-54	50	16' 4"	14' 10"	12' 3"	17' 4" i	15' 0" i	12' 3" i	14' 10"	13' 6"	11' 9"	16' 8" i	15' 0" i	12' 3" i
800S137-68	50	17' 8"	16' 0"	14' 0"	19' 10" i	17' 8" i	14' 5" i	17' 8"	14' 7"	12' 9"	18' 0"	16' 4" i	14' 3" i
800S137-97	50	19' 7"	17' 10"	15' 7"	22' 0"	20' 0"	17' 5" i	17' 10"	16' 2"	14' 2"	20' 0"	18' 2"	15' 10"
800S162-33	33	11' 8" e	10' 1" e	7' 11" e	10' 4" a	8' 4" a	6' 1" a	11' 8" e	10' 1" e	7' 11" e	10' 4" a	8' 4" a	6' 1" a
800S162-43	33	14' 0" e	12' 2" e	9' 11" e	14' 0" i	12' 2" a	9' 10" a	14' 0" e	12' 2" e	9' 11" e	14' 0" i	12' 2" a	9' 10" a
800S162-54	50	17' 0"	15' 5"	13' 3"	18' 9" i	16' 2" i	13' 3" i	15' 5"	14' 0"	12' 3"	17' 4" i	15' 9" i	13' 3" i
800S162-68	50	18' 4"	16' 8"	14' 7"	20' 7" i	18' 9" i	15' 6" i	16' 8"	15' 2"	13' 3"	18' 9"	17' 0" i	14' 10" i
800S162-97	50	20' 5"	18' 6"	16' 2"	22' 11"	20' 10"	18' 2" i	18' 6"	16' 10"	14' 9"	20' 10"	18' 11"	16' 6"

Notes:

- 1 Web punchouts are not considered for shear and web crippling.
- 2 Deflection checks are computed using unbalanced loads for the two equal span conditions.
- 3 "e" indicates that the web stiffeners are required at the end support only.
- 4 "i" indicates that the web stiffeners are required at the interior support only.
- 5 "a" indicates that the web stiffeners are required at all supports.
- 6 See additional floor joist notes on page 62.

Complies with AISI S100-16 (2020) w/S20-2 • IBC 2024

FLOOR JOIST SPAN LIMITATIONS

10psf Dead Load and 50psf Live Load (TL Deflection=L/240)

Member	Yield strength F _y (ksi)	Live Load Deflection L/360						Live Load Deflection L/480					
		Single span spacing (in) o.c.			Two equal span spacing (in) o.c.			Single span spacing (in) o.c.			Two equal span spacing (in) o.c.		
		12	16	24	12	16	24	12	16	24	12	16	24
800S200-33	33	12' 6" e	10' 10" e	7' 11" e	10' 9" a	8' 8" a	6' 3" a	12' 6" e	10' 10" e	7' 11" e	10' 9" a	8' 8" a	6' 3" a
800S200-43	33	15' 1" e	13' 1" e	10' 8" e	15' 1" a	13' 1" a	10' 4" a	15' 1" e	13' 1" e	10' 8" e	15' 1" a	13' 1" a	10' 4" a
800S200-54	50	17' 11"	16' 3"	14' 2"	20' 1" i	17' 4" i	14' 2" i	16' 3"	14' 9"	12' 11"	18' 3" i	16' 7" i	14' 2" i
800S200-68	50	19' 3"	17' 6"	15' 3"	21' 7" i	19' 7" i	16' 7" i	17' 6"	15' 11"	13' 10"	19' 7"	17' 10" i	15' 7" i
800S200-97	50	21' 5"	19' 5"	17' 0"	24' 0"	21' 10"	19' 1" i	19' 5"	17' 8"	15' 5"	21' 10"	19' 10"	17' 4"
800S250-43	33	15' 5" e	13' 5" e	10' 11" e	15' 5" a	13' 5" a	10' 6" a	15' 5" e	13' 5" e	10' 11" e	15' 5" a	13' 5" a	10' 6" a
800S250-54	50	18' 7"	16' 11"	14' 6"	20' 6" i	17' 9" i	14' 6" i	16' 11"	15' 4"	13' 5"	19' 0" i	17' 3" i	14' 6" i
800S250-68	50	20' 1"	18' 3"	15' 11"	22' 6" i	20' 6" i	17' 0" i	18' 3"	16' 7"	14' 6"	20' 6"	18' 7" i	16' 3" i
800S250-97	50	22' 4"	20' 4"	17' 9"	25' 1"	22' 10"	19' 11" i	20' 4"	18' 5"	16' 1"	22' 10"	20' 9"	18' 1"
800S300-54	50	19' 0"	17' 3"	14' 9" e	20' 10" i	18' 0" i	14' 9" i	17' 3"	15' 8"	13' 9"	19' 5" i	17' 7" i	14' 9" i
800S300-68	50	20' 8"	18' 9"	16' 5"	23' 2" i	21' 1" i	17' 3" i	18' 9"	17' 1"	14' 11"	21' 1" i	19' 2" i	16' 9" i
800S300-97	50	23' 2"	21' 0"	18' 4"	26' 0"	23' 7"	20' 7" i	21' 0"	19' 1"	16' 8"	23' 7"	21' 5"	18' 9"
1000S162-43	33	15' 7" e	13' 6" e	11' 0" e	15' 7" a	12' 9" a	9' 6" a	15' 7" e	13' 6" e	11' 0" e	15' 7" a	12' 9" a	9' 6" a
1000S162-54	50	20' 2"	18' 0"	14' 8" e	20' 10" i	18' 0" i	14' 8" i	18' 4"	16' 8"	14' 7" e	20' 7" i	18' 0" i	14' 8" i
1000S162-68	50	21' 11"	19' 11"	17' 4"	24' 6" i	21' 3" i	17' 4" i	19' 11"	18' 1"	15' 9"	22' 4" i	20' 3" i	17' 4" i
1000S162-97	50	24' 7"	22' 4"	19' 6"	27' 7"	25' 1" i	21' 11" i	22' 4"	20' 3"	17' 9"	25' 1"	22' 9"	19' 11" i
1000S200-43	33	16' 10" e	14' 7" e	11' 11" e	16' 4" a	13' 4" a	9' 10" a	16' 10" e	14' 7" e	11' 11" e	16' 4" a	13' 4" a	9' 10" a
1000S200-54	50	21' 1"	19' 2"	15' 10" e	22' 5" i	19' 5" i	15' 8" i	19' 2"	17' 5"	15' 3" e	21' 6" i	19' 5" i	15' 8" i
1000S200-68	50	22' 10"	20' 9"	18' 2"	25' 8" i	22' 10" i	18' 8" i	20' 9"	18' 10"	16' 6"	23' 4" i	21' 2" i	18' 6" i
1000S200-97	50	25' 8"	23' 4"	20' 4"	28' 10"	26' 2" i	22' 10" i	23' 4"	21' 2"	18' 6"	26' 2"	23' 9"	20' 9" i
1000S250-54	50	22' 3"	19' 11"	16' 4" e	23' 1" i	19' 11" i	16' 0" i	20' 3"	18' 5"	16' 1" e	22' 9" i	19' 11" i	16' 0" i
1000S250-68	50	24' 0"	21' 9"	19' 0"	26' 11" i	23' 6" i	19' 2" i	21' 9"	19' 9"	17' 3"	24' 5" i	22' 3" i	19' 2" i
1000S250-97	50	26' 9"	24' 3"	21' 3"	30' 0"	27' 3" i	23' 10" i	24' 3"	22' 1"	19' 3"	27' 3"	24' 9"	21' 8" i
1000S300-54	50	22' 9"	20' 3"	16' 7" e	23' 5" i	20' 3" i	16' 2" i	20' 8"	18' 9"	16' 5" e	23' 2" i	20' 3" i	16' 2" i
1000S300-68	50	24' 8"	22' 5"	19' 6"	27' 7" i	23' 10" i	19' 6" i	22' 5"	20' 4"	17' 9"	25' 2" i	22' 10" i	19' 6" i
1000S300-97	50	27' 7"	25' 1"	21' 11"	30' 11"	28' 1" i	24' 7" i	25' 1"	22' 9"	19' 11"	28' 1"	25' 7"	22' 4" i
1200S162-54	50	22' 5" e	19' 5" e	15' 10" e	22' 5" a	19' 4" a	14' 7" a	21' 1" e	19' 2" e	15' 10" e	22' 5" a	19' 4" a	14' 7" a
1200S162-68	50	25' 3"	22' 11"	18' 10"	26' 7" i	23' 0" i	18' 10" i	22' 11"	20' 10"	18' 2"	25' 9" i	23' 0" i	18' 10" i
1200S162-97	50	28' 7"	26' 0"	22' 8"	32' 1" i	29' 2" i	24' 4" i	26' 0"	23' 7"	20' 7"	29' 2"	26' 6"	23' 2" i
1200S200-54	50	24' 3" e	21' 1" e	17' 2" e	24' 4" a	20' 4" a	15' 2" a	22' 0" e	20' 0" e	17' 2" e	24' 4" a	20' 4" a	15' 2" a
1200S200-68	50	26' 4"	23' 11"	20' 4"	28' 9" i	24' 11" i	20' 4" i	23' 11"	21' 9"	19' 0"	26' 10" i	24' 5" i	20' 4" i
1200S200-97	50	29' 9"	27' 1"	23' 8"	33' 5"	30' 4" i	26' 1" i	27' 1"	24' 7"	21' 6"	30' 4"	27' 7"	24' 1" i

Notes:

- 1 Web punchouts are not considered for shear and web crippling.
- 2 Deflection checks are computed using unbalanced loads for the two equal span conditions.
- 3 "e" indicates that the web stiffeners are required at the end support only.
- 4 "i" indicates that the web stiffeners are required at the interior support only.
- 5 "a" indicates that the web stiffeners are required at all supports.
- 6 See additional floor joist notes on page 62.

Complies with AISI S100-16 (2020) w/S20-2 • IBC 2024

The technical content of this literature is effective 06/01/24 and supersedes all previous information.

FLOOR JOIST SPAN LIMITATIONS

10psf Dead Load and 50psf Live Load (TL Deflection=L/240)

Member	Yield strength F _y (ksi)	Live Load Deflection L/360						Live Load Deflection L/480					
		Single span spacing (in) o.c.			Two equal span spacing (in) o.c.			Single span spacing (in) o.c.			Two equal span spacing (in) o.c.		
		12	16	24	12	16	24	12	16	24	12	16	24
1200S250-54	50	25' 2" e	21' 9" e	17' 9" e	25' 2" a	20' 9" a	15' 6" a	22' 11" e	20' 10" e	17' 9" e	25' 2" a	20' 9" a	15' 6" a
1200S250-68	50	27' 5"	24' 11"	21' 0" e	29' 8" i	25' 9" i	21' 0" i	24' 11"	22' 8"	19' 9"	28' 0" i	25' 5" i	21' 0" i
1200S250-97	50	30' 11"	28' 1"	24' 7"	34' 9" i	31' 7" i	27' 0" i	28' 1"	25' 6"	22' 4"	31' 7"	28' 8"	25' 0" i
1200S300-54	50	25' 8" e	22' 2" e	18' 2" e	25' 8" a	21' 0" a	15' 8" a	24' 0" e	21' 9" e	18' 2" e	25' 8" a	21' 0" a	15' 8" a
1200S300-68	50	28' 6"	25' 11"	21' 5" e	30' 3" i	26' 3" i	21' 5" i	25' 11"	23' 6"	20' 7"	29' 1" i	26' 3" i	21' 5" i
1200S300-97	50	31' 11"	29' 0"	25' 4"	35' 10" i	32' 6" i	27' 7" i	29' 0"	26' 4"	23' 0"	32' 6"	29' 7" i	25' 10" i
1400S162-54	50	23' 8" e	20' 6" e	16' 9" e	23' 0" a	18' 9" a	13' 11" a	23' 8" e	20' 6" e	16' 9" e	23' 0" a	18' 9" a	13' 11" a
1400S162-68	50	28' 3"	24' 6"	20' 0"	28' 3" i	24' 6" i	20' 0" i	25' 10"	23' 6"	20' 0"	28' 3" i	24' 6" i	20' 0" i
1400S162-97	50	32' 5"	29' 5"	25' 9"	36' 4" i	31' 11" i	26' 1" i	29' 5"	26' 9"	23' 4"	33' 1"	30' 0" i	26' 1" i
1400S200-54	50	25' 10" e	22' 5" e	18' 3" e	24' 3" a	19' 8" a	14' 6" a	24' 9" e	22' 5" e	18' 3" e	24' 3" a	19' 8" a	14' 6" a
1400S200-68	50	29' 8"	26' 7"	21' 8" e	30' 8" i	26' 7" i	21' 8" i	26' 11"	24' 6"	21' 5" e	30' 3" i	26' 7" i	21' 8" i
1400S200-97	50	33' 8"	30' 7"	26' 9"	37' 9" i	34' 4" i	28' 1" i	30' 7"	27' 9"	24' 3"	34' 4"	31' 2" i	27' 3" i
1400S250-54	50	26' 11" e	23' 3" e	19' 0" e	24' 9" a	20' 1" a	14' 9" a	25' 9" e	23' 3" e	19' 0" e	24' 9" a	20' 1" a	14' 9" a
1400S250-68	50	30' 10"	27' 7"	22' 6" e	31' 10" i	27' 7" i	22' 4" i	28' 0"	25' 6"	22' 3" e	31' 6" i	27' 7" i	22' 4" i
1400S250-97	50	34' 11"	31' 9"	27' 8"	39' 2" i	35' 7" i	29' 2" i	31' 9"	28' 10"	25' 2"	35' 7"	32' 4" i	28' 3" i
1400S300-54	50	27' 6" e	23' 10" e	19' 6" e	25' 1" a	20' 4" a	14' 10" a	26' 2" e	23' 9" e	19' 6" e	25' 1" a	20' 4" a	14' 10" a
1400S300-68	50	31' 8"	28' 3"	23' 1" e	32' 7" i	28' 3" i	22' 8" i	28' 9"	26' 2"	22' 10" e	32' 4" i	28' 3" i	22' 8" i
1400S300-97	50	36' 0"	32' 8"	28' 7"	40' 5" i	36' 7" i	29' 11" i	32' 8"	29' 8"	25' 11"	36' 8"	33' 4" i	29' 1" i

Notes:

- 1 Web punchouts are not considered for shear and web crippling.
- 2 Deflection checks are computed using unbalanced loads for the two equal span conditions.
- 3 "e" indicates that the web stiffeners are required at the end support only.
- 4 "i" indicates that the web stiffeners are required at the interior support only.
- 5 "a" indicates that the web stiffeners are required at all supports.
- 6 See additional floor joist notes on page 62.

Complies with AISI S100-16 (2020) w/S2-20 • IBC 2024

The technical content of this literature is effective 06/01/24 and supersedes all previous information.

FLOOR JOIST SPAN LIMITATIONS

10psf Dead Load and 100psf Live Load (TL Deflection=L/240)

Member	Yield strength F _y (ksi)	Live Load Deflection L/360						Live Load Deflection L/480					
		Single span spacing (in) o.c.			Two equal span spacing (in) o.c.			Single span spacing (in) o.c.			Two equal span spacing (in) o.c.		
		12	16	24	12	16	24	12	16	24	12	16	24
600S137-33	33	6' 11" e	6' 0" e	4' 10" e	6' 9" a	5' 6" a	4' 1" a	6' 11" e	6' 0" e	4' 10" e	6' 9" a	5' 6" a	4' 1" a
600S137-43	33	8' 3" e	7' 2" e	5' 10" e	8' 3" i	7' 2" a	5' 10" a	8' 3" e	7' 2" e	5' 10" e	8' 3" i	7' 2" a	5' 10" a
600S137-54	50	10' 4"	9' 5"	7' 10"	11' 0" i	9' 7" i	7' 10" i	9' 5"	8' 6"	7' 5"	10' 6" i	9' 7" i	7' 10" i
600S137-68	50	11' 1"	10' 1"	8' 9"	12' 5" i	11' 1" i	9' 1" i	10' 1"	9' 2"	8' 0"	11' 3" i	10' 3" i	8' 11" i
600S137-97	50	12' 3"	11' 1"	9' 9"	13' 9"	12' 6"	10' 11" i	11' 1"	10' 1"	8' 10"	12' 6"	11' 4"	9' 11"
600S162-33	33	7' 5" e	6' 5" e	5' 3" e	7' 0" a	5' 9" a	4' 3" a	7' 5" e	6' 5" e	5' 3" e	7' 0" a	5' 9" a	4' 3" a
600S162-43	33	8' 11" e	7' 8" e	6' 3" e	8' 11" a	7' 8" a	6' 3" a	8' 11" e	7' 8" e	6' 3" e	8' 11" a	7' 8" a	6' 3" a
600S162-54	50	10' 9"	9' 9"	8' 5" e	11' 10" i	10' 3" i	8' 5" i	9' 9"	8' 11"	7' 9"	11' 0" i	10' 0" i	8' 5" i
600S162-68	50	11' 7"	10' 6"	9' 2"	13' 0" i	11' 9" i	9' 9" i	10' 6"	9' 6"	8' 4"	11' 9" i	10' 8" i	9' 4" i
600S162-97	50	12' 10"	11' 8"	10' 2"	14' 4"	13' 1"	11' 5" i	11' 8"	10' 7"	9' 3"	13' 1"	11' 10"	10' 4"
600S200-33	33	8' 0" e	6' 11" e	5' 8" e	7' 4" a	5' 11" a	4' 4" a	8' 0" e	6' 11" e	5' 8" e	7' 4" a	5' 11" a	4' 4" a
600S200-43	33	9' 6" e	8' 3" e	6' 9" e	9' 6" a	8' 3" a	6' 9" a	9' 6" e	8' 3" e	6' 9" e	9' 6" a	8' 3" a	6' 9" a
600S200-54	50	11' 4"	10' 3"	8' 11" e	12' 8" i	11' 0" i	8' 11" i	10' 3"	9' 4"	8' 2"	11' 7" i	10' 6" i	8' 11" i
600S200-68	50	12' 2"	11' 0"	9' 8"	13' 8" i	12' 5" i	10' 5" i	11' 0"	10' 0"	8' 9"	12' 5" i	11' 3" i	9' 10" i
600S200-97	50	13' 6"	12' 3"	10' 8"	15' 2"	13' 9"	12' 0" i	12' 3"	11' 2"	9' 9"	13' 9"	12' 6"	10' 11"
600S250-43	33	9' 9" e	8' 6" e	6' 11" e	9' 9" a	8' 6" a	6' 11" a	9' 9" e	8' 6" e	6' 11" e	9' 9" a	8' 6" a	6' 11" a
600S250-54	50	11' 10"	10' 9"	9' 2" e	13' 0" i	11' 3" i	9' 2" i	10' 9"	9' 9"	8' 6" e	12' 1" i	10' 11" i	9' 2" i
600S250-68	50	12' 9"	11' 7"	10' 1"	14' 4" i	13' 0" i	10' 8" i	11' 7"	10' 6"	9' 2"	13' 0" i	11' 10" i	10' 4" i
600S250-97	50	14' 2"	12' 10"	11' 3"	15' 11"	14' 5"	12' 7" i	12' 10"	11' 8"	10' 3"	14' 5"	13' 1"	11' 6" i
600S300-54	50	12' 1"	10' 11"	9' 4" e	13' 2" i	11' 5" i	9' 4" i	10' 11"	9' 11"	8' 8" e	12' 4" i	11' 2" i	9' 4" i
600S300-68	50	13' 2"	12' 0"	10' 5"	14' 9" i	13' 4" i	10' 11" i	12' 0"	10' 10"	9' 6"	13' 5" i	12' 2" i	10' 8" i
600S300-97	50	14' 9"	13' 4"	11' 8"	16' 6"	15' 0" i	13' 1" i	13' 4"	12' 2"	10' 7"	15' 0" i	13' 8"	11' 11" i
800S137-33	33	7' 11" e	6' 6" e	4' 4" e	6' 4" a	5' 0" a	3' 5" a	7' 11" e	6' 6" e	4' 4" e	6' 4" a	5' 0" a	3' 5" a
800S137-43	33	9' 7" e	8' 3" e	6' 9" e	9' 7" a	8' 2" a	6' 2" a	9' 7" e	8' 3" e	6' 9" e	9' 7" a	8' 2" a	6' 2" a
800S137-54	50	12' 10"	11' 1"	9' 1" e	12' 10" i	11' 1" i	9' 1" i	11' 9"	10' 8"	9' 1" e	12' 10" i	11' 1" i	9' 1" i
800S137-68	50	14' 0"	12' 9"	10' 8"	15' 1" i	13' 0" i	10' 8" i	12' 9"	11' 7"	10' 1"	14' 3" i	13' 0" i	10' 8" i
800S137-97	50	15' 7"	14' 2"	12' 4"	17' 5"	15' 10" i	13' 6" i	14' 2"	12' 10"	11' 3"	15' 10"	14' 5"	12' 7" i
800S162-33	33	8' 7" e	6' 6" e	4' 4" e	6' 6" a	5' 2" a	3' 5" a	8' 7" e	6' 6" e	4' 4" e	6' 6" a	5' 2" a	3' 5" a
800S162-43	33	10' 4" e	9' 0" e	7' 4" e	10' 4" a	8' 7" a	6' 5" a	10' 4" e	9' 0" e	7' 4" e	10' 4" a	8' 7" a	6' 5" a
800S162-54	50	13' 6"	12' 0" e	9' 9" e	13' 10" i	12' 0" i	9' 9" a	12' 3"	11' 1"	9' 9" e	13' 9" i	12' 0" i	9' 9" a
800S162-68	50	14' 7"	13' 3"	11' 5"	16' 2" i	14' 0" i	11' 5" i	13' 3"	12' 0"	10' 6"	14' 10" i	13' 6" i	11' 5" i
800S162-97	50	16' 2"	14' 9"	12' 10"	18' 2"	16' 6" i	14' 5" i	14' 9"	13' 4"	11' 8"	16' 6"	15' 0"	13' 1" i

Notes:

- 1 Web punchouts are not considered for shear and web crippling.
- 2 Deflection checks are computed using unbalanced loads for the two equal span conditions.
- 3 "e" indicates that the web stiffeners are required at the end support only.
- 4 "i" indicates that the web stiffeners are required at the interior support only.
- 5 "a" indicates that the web stiffeners are required at all supports.
- 6 See additional floor joist notes on page 62.

Complies with AISI S100-16 (2020) w/S2-20 • IBC 2024

FLOOR JOIST SPAN LIMITATIONS

10psf Dead Load and 100psf Live Load (TL Deflection=L/240)

Member	Yield strength F _y (ksi)	Live Load Deflection L/360						Live Load Deflection L/480					
		Single span spacing (in) o.c.			Two equal span spacing (in) o.c.			Single span spacing (in) o.c.			Two equal span spacing (in) o.c.		
		12	16	24	12	16	24	12	16	24	12	16	24
800S200-33	33	8' 7" e	6' 6" e	4' 4" e	6' 9" a	5' 2" a	3' 5" a	8' 7" e	6' 6" e	4' 4" e	6' 9" a	5' 2" a	3' 5" a
800S200-43	33	11' 1" e	9' 8" e	7' 10" e	10' 11" a	8' 11" a	6' 8" a	11' 1" e	9' 8" e	7' 10" e	10' 11" a	8' 11" a	6' 8" a
800S200-54	50	14' 3"	12' 10" e	10' 6" e	14' 10" i	12' 10" i	10' 6" a	12' 11"	11' 9"	10' 3" e	14' 6" i	12' 10" i	10' 6" a
800S200-68	50	15' 3"	13' 10"	12' 1" e	17' 2" i	15' 0" i	12' 3" i	13' 10"	12' 7"	11' 0"	15' 7" i	14' 2" i	12' 3" i
800S200-97	50	17' 0"	15' 5"	13' 6"	19' 1"	17' 4" i	15' 2" i	15' 5"	14' 0"	12' 3"	17' 4"	15' 9"	13' 9" i
800S250-43	33	11' 5" e	9' 11" e	8' 1" e	11' 1" a	9' 1" a	6' 9" a	11' 5" e	9' 11" e	8' 1" e	11' 1" a	9' 1" a	6' 9" a
800S250-54	50	14' 9"	13' 2" e	10' 9" e	15' 2" i	13' 2" i	10' 8" a	13' 5"	12' 2" e	10' 8" e	15' 1" i	13' 2" i	10' 8" a
800S250-68	50	15' 11"	14' 6"	12' 7" e	17' 9" i	15' 4" i	12' 7" i	14' 6"	13' 2" e	11' 6"	16' 3" i	14' 9" i	12' 7" i
800S250-97	50	17' 9"	16' 1"	14' 1"	19' 11"	18' 1" i	15' 10" i	16' 1"	14' 8"	12' 10"	18' 1"	16' 5"	14' 4" i
800S300-54	50	15' 1"	13' 4" e	10' 11" e	15' 5" i	13' 4" i	10' 9" a	13' 9"	12' 5" e	10' 11" e	15' 5" i	13' 4" i	10' 9" a
800S300-68	50	16' 5"	14' 11"	12' 9" e	18' 1" i	15' 8" i	12' 9" i	14' 11"	13' 6"	11' 10"	16' 9" i	15' 2" i	12' 9" i
800S300-97	50	18' 4"	16' 8"	14' 7"	20' 7" i	18' 9" i	16' 3" i	16' 8"	15' 2"	13' 3"	18' 9"	17' 0" i	14' 10" i
1000S162-43	33	11' 6" e	9' 11" e	7' 7" e	10' 1" a	8' 2" a	5' 11" a	11' 6" e	9' 11" e	7' 7" e	10' 1" a	8' 2" a	5' 11" a
1000S162-54	50	15' 4" e	13' 4" e	10' 10" e	15' 4" i	13' 1" i	9' 9" a	14' 7"	13' 3" e	10' 10" e	15' 4" i	13' 1" i	9' 9" a
1000S162-68	50	17' 4"	15' 8"	12' 10" e	18' 1" i	15' 8" i	12' 10" i	15' 9"	14' 4"	12' 6" e	17' 9" i	15' 8" i	12' 10" i
1000S162-97	50	19' 6"	17' 9"	15' 6"	21' 11" i	19' 11" i	16' 5" i	17' 9"	16' 1"	14' 1"	19' 11"	18' 1" i	15' 9" i
1000S200-43	33	12' 5" e	10' 9" e	7' 7" e	10' 6" a	8' 5" a	6' 1" a	12' 5" e	10' 9" e	7' 7" e	10' 6" a	8' 5" a	6' 1" a
1000S200-54	50	16' 7" e	14' 4" e	11' 9" e	16' 7" i	13' 8" a	10' 2" a	15' 3"	13' 10" e	11' 9" e	16' 7" i	13' 8" a	10' 2" a
1000S200-68	50	18' 2"	16' 6"	13' 9" e	19' 6" i	16' 10" i	13' 9" a	16' 6"	15' 0"	13' 1" e	18' 6" i	16' 10" i	13' 9" a
1000S200-97	50	20' 4"	18' 6"	16' 2"	22' 10" i	20' 9" i	17' 6" i	18' 6"	16' 10"	14' 8"	20' 9"	18' 11" i	16' 6" i
1000S250-54	50	17' 0" e	14' 9" e	12' 0" e	17' 0" i	13' 10" a	10' 4" a	16' 1" e	14' 7" e	12' 0" e	17' 0" i	13' 10" a	10' 4" a
1000S250-68	50	19' 0"	17' 3"	14' 2" e	20' 0" i	17' 4" i	14' 2" a	17' 3"	15' 8"	13' 9" e	19' 5" i	17' 4" i	14' 2" a
1000S250-97	50	21' 3"	19' 3"	16' 10"	23' 10" i	21' 8" i	18' 1" i	19' 3"	17' 6"	15' 4"	21' 8"	19' 8" i	17' 2" i
1000S300-54	50	17' 3" e	15' 0" e	12' 3" e	17' 1" i	14' 0" a	10' 5" a	16' 5" e	14' 11" e	12' 3" e	17' 1" i	14' 0" a	10' 5" a
1000S300-68	50	19' 7"	17' 7" e	14' 5" e	20' 4" i	17' 7" i	14' 5" a	17' 9"	16' 2"	14' 1" e	19' 11" i	17' 7" i	14' 5" a
1000S300-97	50	21' 11"	19' 11"	17' 4"	24' 7" i	22' 4" i	18' 5" i	19' 11"	18' 1"	15' 9"	22' 4" i	20' 3" i	17' 9" i
1200S162-54	50	16' 7" e	14' 4" e	11' 8" e	15' 6" a	12' 7" a	9' 3" a	16' 7" e	14' 4" e	11' 8" e	15' 6" a	12' 7" a	9' 3" a
1200S162-68	50	19' 8"	17' 0" e	13' 11" e	19' 8" i	17' 0" i	13' 11" a	18' 2"	16' 6"	13' 11" e	19' 8" i	17' 0" i	13' 11" a
1200S162-97	50	22' 8"	20' 7"	18' 0"	25' 5" i	22' 0" i	18' 0" i	20' 7"	18' 9"	16' 4"	23' 2" i	21' 0" i	18' 0" i
1200S200-54	50	18' 0" e	15' 7" e	12' 6" e	16' 3" a	13' 1" a	9' 7" a	17' 6" e	15' 7" e	12' 6" e	16' 3" a	13' 1" a	9' 7" a
1200S200-68	50	20' 11"	18' 5" e	15' 0" e	21' 3" i	18' 5" i	14' 8" a	19' 0"	17' 3" e	15' 0" e	21' 3" i	18' 5" i	14' 8" a
1200S200-97	50	23' 8"	21' 6"	18' 9"	26' 6" i	23' 7" i	19' 3" i	21' 6"	19' 6"	17' 0"	24' 1" i	21' 11" i	19' 2" i

Notes:

- 1 Web punchouts are not considered for shear and web crippling.
- 2 Deflection checks are computed using unbalanced loads for the two equal span conditions.
- 3 "e" indicates that the web stiffeners are required at the end support only.
- 4 "i" indicates that the web stiffeners are required at the interior support only.
- 5 "a" indicates that the web stiffeners are required at all supports.
- 6 See additional floor joist notes on page 62.

FLOOR JOIST SPAN LIMITATIONS

10psf Dead Load and 100psf Live Load (TL Deflection=L/240)

Member	Yield strength F _y (ksi)	Live Load Deflection L/360						Live Load Deflection L/480					
		Single span spacing (in) o.c.			Two equal span spacing (in) o.c.			Single span spacing (in) o.c.			Two equal span spacing (in) o.c.		
		12	16	24	12	16	24	12	16	24	12	16	24
1200S250-54	50	18' 7" e	16' 1" e	12' 6" e	16' 6" a	13' 4" a	9' 9" a	18' 3" e	16' 1" e	12' 6" e	16' 6" a	13' 4" a	9' 9" a
1200S250-68	50	21' 9"	19' 0" e	15' 6" e	21' 11" i	19' 0" i	14' 11" a	19' 9"	18' 0" e	15' 6" e	21' 11" i	19' 0" i	14' 11" a
1200S250-97	50	24' 7"	22' 4"	19' 6"	27' 7" i	24' 5" i	19' 11" i	22' 4"	20' 3"	17' 8"	25' 0" i	22' 9" i	19' 10" i
1200S300-54	50	18' 11" e	16' 5" e	12' 6" e	16' 8" a	13' 5" a	9' 9" a	18' 11" e	16' 5" e	12' 6" e	16' 8" a	13' 5" a	9' 9" a
1200S300-68	50	22' 4"	19' 4" e	15' 10" e	22' 4" i	19' 4" i	15' 1" a	20' 7"	18' 8" e	15' 10" e	22' 4" i	19' 4" i	15' 1" a
1200S300-97	50	25' 4"	23' 0"	20' 1"	28' 5" i	24' 11" i	20' 4" i	23' 0"	20' 11"	18' 3"	25' 10" i	23' 5" i	20' 4" i
1400S162-54	50	17' 6" e	15' 2" e	10' 8" e	14' 10" a	11' 11" a	8' 7" a	17' 6" e	15' 2" e	10' 8" e	14' 10" a	11' 11" a	8' 7" a
1400S162-68	50	20' 10"	18' 1" e	14' 9" e	20' 10" i	18' 0" i	13' 7" a	20' 6"	18' 1" e	14' 9" e	20' 10" i	18' 0" i	13' 7" a
1400S162-97	50	25' 9"	23' 4"	19' 3"	27' 3" i	23' 7" i	19' 3" i	23' 4"	21' 3"	18' 7"	26' 3" i	23' 7" i	19' 3" i
1400S200-54	50	19' 1" e	16' 0" e	10' 8" e	15' 6" a	12' 4" a	8' 7" a	19' 1" e	16' 0" e	10' 8" e	15' 6" a	12' 4" a	8' 7" a
1400S200-68	50	22' 8" e	19' 8" e	16' 0" e	22' 8" i	19' 0" a	14' 2" a	21' 5"	19' 5" e	16' 0" e	22' 8" i	19' 0" a	14' 2" a
1400S200-97	50	26' 9"	24' 3"	20' 9"	29' 4" i	25' 5" i	20' 9" i	24' 3"	22' 1"	19' 3"	27' 3" i	24' 9" i	20' 9" i
1400S250-54	50	19' 10" e	16' 0" e	10' 8" e	15' 9" a	12' 6" a	8' 7" a	19' 10" e	16' 0" e	10' 8" e	15' 9" a	12' 6" a	8' 7" a
1400S250-68	50	23' 6" e	20' 5" e	16' 8" e	23' 6" i	19' 5" a	14' 6" a	22' 3" e	20' 2" e	16' 8" e	23' 6" i	19' 5" a	14' 6" a
1400S250-97	50	27' 8"	25' 2"	21' 7" e	30' 6" i	26' 5" i	21' 7" i	25' 2"	22' 10"	20' 0"	28' 3" i	25' 8" i	21' 7" i
1400S300-54	50	20' 4" e	16' 0" e	10' 8" e	15' 11" a	12' 8" a	8' 7" a	20' 4" e	16' 0" e	10' 8" e	15' 11" a	12' 8" a	8' 7" a
1400S300-68	50	24' 1" e	20' 10" e	17' 0" e	24' 1" i	19' 8" a	14' 8" a	22' 10" e	20' 9" e	17' 0" e	24' 1" i	19' 8" a	14' 8" a
1400S300-97	50	28' 7"	25' 11"	22' 1" e	31' 3" i	27' 0" i	22' 1" i	25' 11"	23' 7"	20' 7"	29' 1" i	26' 5" i	22' 1" i

Notes:

- 1 Web punchouts are not considered for shear and web crippling.
- 2 Deflection checks are computed using unbalanced loads for the two equal span conditions.
- 3 "e" indicates that the web stiffeners are required at the end support only.
- 4 "i" indicates that the web stiffeners are required at the interior support only.
- 5 "a" indicates that the web stiffeners are required at all supports.
- 6 See additional floor joist notes on page 62.

Complies with AISI S100-16 (2020) w/S2-20 • IBC 2024

The technical content of this literature is effective 06/01/24 and supersedes all previous information.

FLOOR JOIST SPAN LIMITATIONS

10psf Dead Load and 125psf Live Load (TL Deflection=L/240)

Member	Yield strength F _y (ksi)	Live Load Deflection L/360						Live Load Deflection L/480					
		Single span spacing (in) o.c.			Two equal span spacing (in) o.c.			Single span spacing (in) o.c.			Two equal span spacing (in) o.c.		
		12	16	24	12	16	24	12	16	24	12	16	24
600S137-33	33	6' 3" e	5' 5" e	4' 5" e	5' 10" a	4' 9" a	3' 5" a	6' 3" e	5' 5" e	4' 5" e	5' 10" a	4' 9" a	3' 5" a
600S137-43	33	7' 5" e	6' 5" e	5' 3" e	7' 5" a	6' 5" a	5' 3" a	7' 5" e	6' 5" e	5' 3" e	7' 5" a	6' 5" a	5' 3" a
600S137-54	50	9' 7"	8' 7"	7' 0" e	9' 11" i	8' 7" i	7' 0" i	8' 8"	7' 11"	6' 11" e	9' 9" i	8' 7" i	7' 0" i
600S137-68	50	10' 3"	9' 4"	8' 2"	11' 6" i	10' 0" i	8' 2" i	9' 4"	8' 6"	7' 5"	10' 6" i	9' 6" i	8' 2" i
600S137-97	50	11' 4"	10' 4"	9' 0"	12' 9"	11' 7" i	10' 1" i	10' 4"	9' 4"	8' 2"	11' 7"	10' 6"	9' 2" i
600S162-33	33	6' 9" e	5' 10" e	4' 9" e	6' 1" a	4' 11" a	3' 7" a	6' 9" e	5' 10" e	4' 9" e	6' 1" a	4' 11" a	3' 7" a
600S162-43	33	8' 0" e	6' 11" e	5' 8" e	8' 0" a	6' 11" a	5' 8" a	8' 0" e	6' 11" e	5' 8" e	8' 0" a	6' 11" a	5' 8" a
600S162-54	50	10' 0"	9' 1"	7' 7" e	10' 8" i	9' 3" i	7' 7" i	9' 1"	8' 3" e	7' 3" e	10' 2" i	9' 3" i	7' 7" i
600S162-68	50	10' 9"	9' 9"	8' 6"	12' 0" i	10' 9" i	8' 9" i	9' 9"	8' 10"	7' 9"	10' 11" i	9' 11" i	8' 8" i
600S162-97	50	11' 11"	10' 10"	9' 5"	13' 4"	12' 1" i	10' 7" i	10' 10"	9' 10"	8' 7"	12' 1"	11' 0"	9' 7" i
600S200-33	33	7' 2" e	6' 3" e	4' 9" e	6' 4" a	5' 1" a	3' 8" a	7' 2" e	6' 3" e	4' 9" e	6' 4" a	5' 1" a	3' 8" a
600S200-43	33	8' 7" e	7' 5" e	6' 1" e	8' 7" a	7' 5" a	6' 0" a	8' 7" e	7' 5" e	6' 1" e	8' 7" a	7' 5" a	6' 0" a
600S200-54	50	10' 6"	9' 7"	8' 1" e	11' 5" i	9' 11" i	8' 1" a	9' 7"	8' 8"	7' 7" e	10' 9" i	9' 9" i	8' 1" a
600S200-68	50	11' 3"	10' 3"	8' 11"	12' 8" i	11' 6" i	9' 5" i	10' 3"	9' 4"	8' 2"	11' 6" i	10' 5" i	9' 2" i
600S200-97	50	12' 6"	11' 4"	9' 11"	14' 1"	12' 9" i	11' 2" i	11' 4"	10' 4"	9' 0"	12' 9"	11' 7"	10' 2" i
600S250-43	33	8' 10" e	7' 8" e	6' 3" e	8' 10" a	7' 8" a	6' 1" a	8' 10" e	7' 8" e	6' 3" e	8' 10" a	7' 8" a	6' 1" a
600S250-54	50	11' 0"	9' 11"	8' 3" e	11' 8" i	10' 2" i	8' 3" a	9' 11"	9' 1"	7' 11" e	11' 2" i	10' 2" i	8' 3" a
600S250-68	50	11' 10"	10' 9"	9' 5"	13' 3" i	11' 10" i	9' 8" i	10' 9"	9' 9"	8' 6"	12' 1" i	10' 11" i	9' 7" i
600S250-97	50	13' 2"	11' 11"	10' 5"	14' 9"	13' 5" i	11' 9" i	11' 11"	10' 10"	9' 6"	13' 5"	12' 2"	10' 8" i
600S300-54	50	11' 2"	10' 2" e	8' 5" e	11' 11" i	10' 4" i	8' 5" a	10' 2"	9' 3"	8' 1" e	11' 5" i	10' 4" i	8' 5" a
600S300-68	50	12' 3"	11' 1"	9' 8"	13' 9" i	12' 1" i	9' 10" i	11' 1"	10' 1"	8' 10"	12' 6" i	11' 4" i	9' 10" i
600S300-97	50	13' 8"	12' 5"	10' 10"	15' 4"	13' 11" i	12' 2" i	12' 5"	11' 3"	9' 10"	13' 11" i	12' 8"	11' 1" i
800S137-33	33	7' 0" e	5' 3" e	3' 6" e	5' 4" a	4' 3" a	2' 10" a	7' 0" e	5' 3" e	3' 6" e	5' 4" a	4' 3" a	2' 10" a
800S137-43	33	8' 8" e	7' 6" e	6' 1" e	8' 8" a	7' 1" a	5' 3" a	8' 8" e	7' 6" e	6' 1" e	8' 8" a	7' 1" a	5' 3" a
800S137-54	50	11' 7"	10' 0" e	8' 2" e	11' 7" i	10' 0" i	8' 2" a	10' 11"	9' 11" e	8' 2" e	11' 7" i	10' 0" i	8' 2" a
800S137-68	50	13' 0"	11' 9"	9' 7"	13' 7" i	11' 9" i	9' 7" i	11' 10"	10' 9"	9' 5"	13' 3" i	11' 9" i	9' 7" i
800S137-97	50	14' 5"	13' 1"	11' 5"	16' 2" i	14' 9" i	12' 2" i	13' 1"	11' 11"	10' 5"	14' 9"	13' 5" i	11' 8" i
800S162-33	33	7' 0" e	5' 3" e	3' 6" e	5' 6" a	4' 3" a	2' 10" a	7' 0" e	5' 3" e	3' 6" e	5' 6" a	4' 3" a	2' 10" a
800S162-43	33	9' 4" e	8' 1" e	6' 7" e	9' 1" a	7' 5" a	5' 6" a	9' 4" e	8' 1" e	6' 7" e	9' 1" a	7' 5" a	5' 6" a
800S162-54	50	12' 6"	10' 10" e	8' 10" e	12' 6" i	10' 10" i	8' 9" a	11' 4"	10' 4" e	8' 10" e	12' 6" i	10' 10" i	8' 9" a
800S162-68	50	13' 6"	12' 3"	10' 4" e	14' 7" i	12' 8" i	10' 4" i	12' 3"	11' 2"	9' 9"	13' 10" i	12' 6" i	10' 4" i
800S162-97	50	15' 0"	13' 8"	11' 11"	16' 11" i	15' 4" i	13' 1" i	13' 8"	12' 5"	10' 10"	15' 4"	13' 11" i	12' 2" i

Notes:

- 1 Web punchouts are not considered for shear and web crippling.
- 2 Deflection checks are computed using unbalanced loads for the two equal span conditions.
- 3 "e" indicates that the web stiffeners are required at the end support only.
- 4 "i" indicates that the web stiffeners are required at the interior support only.
- 5 "a" indicates that the web stiffeners are required at all supports.
- 6 See additional floor joist notes on page 62.

Complies with AISI S100-16 (2020) w/S20-2 • IBC 2024

FLOOR JOIST SPAN LIMITATIONS

10psf Dead Load and 125psf Live Load (TL Deflection=L/240)

Member	Yield strength Fy (ksi)	Live Load Deflection L/360						Live Load Deflection L/480					
		Single span spacing (in) o.c.			Two equal span spacing (in) o.c.			Single span spacing (in) o.c.			Two equal span spacing (in) o.c.		
		12	16	24	12	16	24	12	16	24	12	16	24
800S200-33	33	7' 0" e	5' 3" e	3' 6" e	5' 7" a	4' 3" a	2' 10" a	7' 0" e	5' 3" e	3' 6" e	5' 7" a	4' 3" a	2' 10" a
800S200-43	33	10' 0" e	8' 8" e	7' 1" e	9' 6" a	7' 8" a	5' 8" a	10' 0" e	8' 8" e	7' 1" e	9' 6" a	7' 8" a	5' 8" a
800S200-54	50	13' 2" e	11' 7" e	9' 5" e	13' 4" i	11' 7" a	9' 1" a	12' 0" e	10' 11" e	9' 5" e	13' 4" i	11' 7" a	9' 1" a
800S200-68	50	14' 2" e	12' 11" e	11' 1" e	15' 7" i	13' 6" i	11' 1" i	12' 11" e	11' 8" e	10' 3" e	14' 5" i	13' 2" i	11' 1" i
800S200-97	50	15' 9" e	14' 4" e	12' 6" e	17' 8" i	16' 1" i	13' 11" i	14' 4" e	13' 0" e	11' 4" e	16' 1" e	14' 7" i	12' 9" i
800S250-43	33	10' 4" e	8' 11" e	7' 3" e	9' 8" a	7' 10" a	5' 9" a	10' 4" e	8' 11" e	7' 3" e	9' 8" a	7' 10" a	5' 9" a
800S250-54	50	13' 8" e	11' 10" e	9' 8" e	13' 8" i	11' 10" a	9' 3" a	12' 6" e	11' 4" e	9' 8" e	13' 8" i	11' 10" a	9' 3" a
800S250-68	50	14' 9" e	13' 5" e	11' 4" e	16' 0" i	13' 11" i	11' 4" a	13' 5" e	12' 2" e	10' 8" e	15' 1" i	13' 8" i	11' 4" a
800S250-97	50	16' 6" e	15' 0" e	13' 1" e	18' 6" i	16' 10" i	14' 4" i	15' 0" e	13' 7" e	11' 11" e	16' 10" e	15' 3" i	13' 4" i
800S300-54	50	13' 11" e	12' 0" e	9' 10" e	13' 11" i	12' 0" a	9' 4" a	12' 9" e	11' 7" e	9' 10" e	13' 11" i	12' 0" a	9' 4" a
800S300-68	50	15' 3" e	13' 10" e	11' 6" e	16' 3" i	14' 1" i	11' 6" a	13' 10" e	12' 7" e	11' 0" e	15' 6" i	14' 1" i	11' 6" a
800S300-97	50	17' 1" e	15' 6" e	13' 6" e	19' 2" i	17' 5" i	14' 8" i	15' 6" e	14' 1" e	12' 4" e	17' 5" e	15' 10" i	13' 10" i
1000S162-43	33	10' 5" e	9' 0" e	6' 2" e	8' 8" a	7' 0" a	4' 11" a	10' 5" e	9' 0" e	6' 2" e	8' 8" a	7' 0" a	4' 11" a
1000S162-54	50	13' 10" e	12' 0" e	9' 10" e	13' 10" i	11' 4" a	8' 5" a	13' 6" e	12' 0" e	9' 10" e	13' 10" i	11' 4" a	8' 5" a
1000S162-68	50	16' 1" e	14' 2" e	11' 7" e	16' 4" i	14' 2" i	11' 7" a	14' 8" e	13' 4" e	11' 7" e	16' 4" i	14' 2" i	11' 7" a
1000S162-97	50	18' 1" e	16' 5" e	14' 4" e	20' 4" i	18' 1" i	14' 10" i	16' 5" e	14' 11" e	13' 1" e	18' 6" i	16' 9" i	14' 8" i
1000S200-43	33	11' 3" e	9' 3" e	6' 2" e	9' 0" a	7' 2" a	4' 11" a	11' 3" e	9' 3" e	6' 2" e	9' 0" a	7' 2" a	4' 11" a
1000S200-54	50	14' 11" e	12' 11" e	10' 7" e	14' 5" a	11' 9" a	8' 9" a	14' 2" e	12' 10" e	10' 7" e	14' 5" a	11' 9" a	8' 9" a
1000S200-68	50	16' 10" e	15' 3" e	12' 5" e	17' 7" i	15' 3" i	12' 5" a	15' 4" e	13' 11" e	12' 2" e	17' 2" i	15' 3" i	12' 5" a
1000S200-97	50	18' 11" e	17' 2" e	15' 0" e	21' 3" i	19' 3" i	15' 10" i	17' 2" e	15' 7" e	13' 8" e	19' 3" i	17' 6" i	15' 4" i
1000S250-54	50	15' 4" e	13' 4" e	10' 10" e	14' 8" a	12' 0" a	8' 10" a	14' 11" e	13' 4" e	10' 10" e	14' 8" a	12' 0" a	8' 10" a
1000S250-68	50	17' 8" e	15' 8" e	12' 9" e	18' 1" i	15' 8" i	12' 9" a	16' 0" e	14' 7" e	12' 9" e	18' 0" i	15' 8" i	12' 9" a
1000S250-97	50	19' 8" e	17' 11" e	15' 8" e	22' 1" i	20' 0" i	16' 4" i	17' 11" e	16' 3" e	14' 2" e	20' 1" i	18' 3" i	15' 11" i
1000S300-54	50	15' 7" e	13' 6" e	11' 0" e	14' 10" a	12' 1" a	8' 11" a	15' 3" e	13' 6" e	11' 0" e	14' 10" a	12' 1" a	8' 11" a
1000S300-68	50	18' 2" e	15' 11" e	13' 0" e	18' 4" i	15' 11" i	13' 0" a	16' 6" e	15' 0" e	13' 0" e	18' 4" i	15' 11" i	13' 0" a
1000S300-97	50	20' 4" e	18' 5" e	16' 1" e	22' 10" i	20' 4" i	16' 7" i	18' 5" e	16' 9" e	14' 8" e	20' 9" i	18' 10" i	16' 5" i
1200S162-54	50	14' 11" e	12' 11" e	10' 2" e	13' 4" a	10' 9" a	7' 10" a	14' 11" e	12' 11" e	10' 2" e	13' 4" a	10' 9" a	7' 10" a
1200S162-68	50	17' 9" e	15' 4" e	12' 7" e	17' 9" i	15' 4" i	12' 2" a	16' 11" e	15' 4" e	12' 7" e	17' 9" i	15' 4" i	12' 2" a
1200S162-97	50	21' 1" e	19' 2" e	16' 3" e	22' 11" i	19' 10" i	16' 3" i	19' 2" e	17' 5" e	15' 2" e	21' 6" i	19' 6" i	16' 3" i
1200S200-54	50	16' 3" e	14' 1" e	10' 2" e	13' 11" a	11' 2" a	8' 1" a	16' 3" e	14' 1" e	10' 2" e	13' 11" a	11' 2" a	8' 1" a
1200S200-68	50	19' 2" e	16' 7" e	13' 7" e	19' 2" i	16' 7" a	12' 8" a	17' 7" e	16' 0" e	13' 7" e	19' 2" i	16' 7" a	12' 8" a
1200S200-97	50	21' 11" e	19' 11" e	17' 5" e	24' 7" i	21' 4" i	17' 5" i	19' 11" e	18' 1" e	15' 10" e	22' 4" i	20' 4" i	17' 5" i

Notes:

- 1 Web punchouts are not considered for shear and web crippling.
- 2 Deflection checks are computed using unbalanced loads for the two equal span conditions.
- 3 "e" indicates that the web stiffeners are required at the end support only.
- 4 "i" indicates that the web stiffeners are required at the interior support only.
- 5 "a" indicates that the web stiffeners are required at all supports.
- 6 See additional floor joist notes on page 62.

Complies with AISI S100-16 (2020) w/S20-2 • IBC 2024

The technical content of this literature is effective 06/01/24 and supersedes all previous information.

FLOOR JOIST SPAN LIMITATIONS

10psf Dead Load and 125psf Live Load (TL Deflection=L/240)

Member	Yield strength F _y (ksi)	Live Load Deflection L/360						Live Load Deflection L/480					
		Single span spacing (in) o.c.			Two equal span spacing (in) o.c.			Single span spacing (in) o.c.			Two equal span spacing (in) o.c.		
		12	16	24	12	16	24	12	16	24	12	16	24
1200S250-54	50	16' 9" e	14' 6" e	10' 2" e	14' 2" a	11' 4" a	8' 2" a	16' 9" e	14' 6" e	10' 2" e	14' 2" a	11' 4" a	8' 2" a
1200S250-68	50	19' 10" e	17' 2" e	14' 0" e	19' 10" i	17' 2" a	12' 11" a	18' 4" e	16' 8" e	14' 0" e	19' 10" i	17' 2" a	12' 11" a
1200S250-97	50	22' 9"	20' 8"	18' 0" e	25' 5" i	22' 0" i	18' 0" i	20' 8"	18' 10"	16' 5"	23' 3" i	21' 1" i	18' 0" i
1200S300-54	50	17' 1" e	14' 10" e	10' 2" e	14' 4" a	11' 5" a	8' 2" a	17' 1" e	14' 10" e	10' 2" e	14' 4" a	11' 5" a	8' 2" a
1200S300-68	50	20' 2" e	17' 6" e	14' 3" e	20' 2" i	17' 4" a	13' 1" a	19' 1" e	17' 4" e	14' 3" e	20' 2" i	17' 4" a	13' 1" a
1200S300-97	50	23' 6"	21' 4"	18' 5" e	26' 0" i	22' 6" i	18' 5" i	21' 4"	19' 5"	16' 11"	24' 0" i	21' 9" i	18' 5" i
1400S162-54	50	15' 10" e	13' 1" e	8' 9" e	12' 8" a	10' 1" a	7' 0" a	15' 10" e	13' 1" e	8' 9" e	12' 8" a	10' 1" a	7' 0" a
1400S162-68	50	18' 10" e	16' 4" e	13' 4" e	18' 10" i	15' 8" a	11' 8" a	18' 10" e	16' 4" e	13' 4" e	18' 10" i	15' 8" a	11' 8" a
1400S162-97	50	23' 10"	21' 4"	17' 5" e	24' 7" i	21' 4" i	17' 5" i	21' 8"	19' 8"	17' 3" e	24' 4" i	21' 4" i	17' 5" i
1400S200-54	50	17' 3" e	13' 1" e	8' 9" e	13' 2" a	10' 5" a	7' 0" a	17' 3" e	13' 1" e	8' 9" e	13' 2" a	10' 5" a	7' 0" a
1400S200-68	50	20' 6" e	17' 9" e	14' 6" e	20' 2" i	16' 5" a	12' 2" a	19' 10" e	17' 9" e	14' 6" e	20' 2" i	16' 5" a	12' 2" a
1400S200-97	50	24' 10"	22' 6"	18' 9" e	26' 6" i	23' 0" i	18' 9" i	22' 6"	20' 6"	17' 11" e	25' 4" i	23' 0" i	18' 9" i
1400S250-54	50	17' 5" e	13' 1" e	8' 9" e	13' 5" a	10' 5" a	7' 0" a	17' 5" e	13' 1" e	8' 9" e	13' 5" a	10' 5" a	7' 0" a
1400S250-68	50	21' 3" e	18' 5" e	15' 0" e	20' 7" a	16' 9" a	12' 5" a	20' 8" e	18' 5" e	15' 0" e	20' 7" a	16' 9" a	12' 5" a
1400S250-97	50	25' 9"	23' 4"	19' 5" e	27' 6" i	23' 10" i	19' 5" i	23' 4"	21' 3"	18' 7" e	26' 3" i	23' 10" i	19' 5" i
1400S300-54	50	17' 5" e	13' 1" e	8' 9" e	13' 6" a	10' 5" a	7' 0" a	17' 5" e	13' 1" e	8' 9" e	13' 6" a	10' 5" a	7' 0" a
1400S300-68	50	21' 9" e	18' 10" e	15' 5" e	20' 10" a	17' 0" a	12' 7" a	21' 2" e	18' 10" e	15' 5" e	20' 10" a	17' 0" a	12' 7" a
1400S300-97	50	26' 6"	24' 1"	19' 11" e	28' 2" i	24' 5" i	19' 11" a	24' 1"	21' 11"	19' 1" e	27' 0" i	24' 5" i	19' 11" a

Notes:

- 1 Web punchouts are not considered for shear and web crippling.
- 2 Deflection checks are computed using unbalanced loads for the two equal span conditions.
- 3 "e" indicates that the web stiffeners are required at the end support only.
- 4 "i" indicates that the web stiffeners are required at the interior support only.
- 5 "a" indicates that the web stiffeners are required at all supports.
- 6 See additional floor joist notes on page 62.

Complies with AISI S100-16 (2020) w/S2-20 • IBC 2024

The technical content of this literature is effective 06/01/24 and supersedes all previous information.

FLOOR JOIST SPAN LIMITATIONS

15psf Dead Load and 125psf Live Load (TL Deflection=L/240)

Member	Yield strength F _y (ksi)	Live Load Deflection L/360						Live Load Deflection L/480					
		Single span spacing (in) o.c.			Two equal span spacing (in) o.c.			Single span spacing (in) o.c.			Two equal span spacing (in) o.c.		
		12	16	24	12	16	24	12	16	24	12	16	24
600S137-33	33	6' 1" e	5' 3" e	4' 4" e	5' 8" a	4' 7" a	3' 4" a	6' 1" e	5' 3" e	4' 4" e	5' 8" a	4' 7" a	3' 4" a
600S137-43	33	7' 4" e	6' 4" e	5' 2" e	7' 4" a	6' 4" a	5' 2" a	7' 4" e	6' 4" e	5' 2" e	7' 4" a	6' 4" a	5' 2" a
600S137-54	50	9' 7" e	8' 6" e	6' 11" e	9' 9" i	8' 6" i	6' 11" i	8' 8" e	7' 11" e	6' 11" e	9' 9" i	8' 6" i	6' 11" i
600S137-68	50	10' 3" e	9' 4" e	8' 1" e	11' 5" i	9' 10" i	8' 1" i	9' 4" e	8' 6" e	7' 5" e	10' 6" i	9' 6" i	8' 1" i
600S137-97	50	11' 4" e	10' 4" e	9' 0" e	12' 9" i	11' 7" i	9' 11" i	10' 4" e	9' 4" e	8' 2" e	11' 7" e	10' 6" e	9' 2" i
600S162-33	33	6' 7" e	5' 9" e	4' 7" e	5' 11" a	4' 9" a	3' 6" a	6' 7" e	5' 9" e	4' 7" e	5' 11" a	4' 9" a	3' 6" a
600S162-43	33	7' 11" e	6' 10" e	5' 7" e	7' 11" a	6' 10" a	5' 7" a	7' 11" e	6' 10" e	5' 7" e	7' 11" a	6' 10" a	5' 7" a
600S162-54	50	10' 0" e	9' 1" e	7' 5" e	10' 6" i	9' 1" i	7' 5" i	9' 1" e	8' 3" e	7' 3" e	10' 2" i	9' 1" i	7' 5" i
600S162-68	50	10' 9" e	9' 9" e	8' 6" e	12' 0" i	10' 7" i	8' 8" i	9' 9" e	8' 10" e	7' 9" e	10' 11" i	9' 11" i	8' 8" i
600S162-97	50	11' 11" e	10' 10" e	9' 5" e	13' 4" i	12' 1" i	10' 7" i	10' 10" e	9' 10" e	8' 7" e	12' 1" e	11' 0" e	9' 7" i
600S200-33	33	7' 1" e	6' 1" e	4' 7" e	6' 2" a	4' 11" a	3' 7" a	7' 1" e	6' 1" e	4' 7" e	6' 2" a	4' 11" a	3' 7" a
600S200-43	33	8' 5" e	7' 4" e	6' 0" e	8' 5" a	7' 4" a	5' 10" a	8' 5" e	7' 4" e	6' 0" e	8' 5" a	7' 4" a	5' 10" a
600S200-54	50	10' 6" e	9' 7" e	7' 11" e	11' 3" i	9' 9" i	7' 11" a	9' 7" e	8' 8" e	7' 7" e	10' 9" i	9' 9" i	7' 11" a
600S200-68	50	11' 3" e	10' 3" e	8' 11" e	12' 8" i	11' 3" i	9' 3" i	10' 3" e	9' 4" e	8' 2" e	11' 6" i	10' 5" i	9' 2" i
600S200-97	50	12' 6" e	11' 4" e	9' 11" e	14' 1" i	12' 9" i	11' 2" i	11' 4" e	10' 4" e	9' 0" e	12' 9" e	11' 7" e	10' 2" i
600S250-43	33	8' 8" e	7' 6" e	6' 1" e	8' 8" a	7' 6" a	5' 11" a	8' 8" e	7' 6" e	6' 1" e	8' 8" a	7' 6" a	5' 11" a
600S250-54	50	11' 0" e	9' 11" e	8' 2" e	11' 6" i	9' 11" i	8' 2" a	9' 11" e	9' 1" e	7' 11" e	11' 2" i	9' 11" i	8' 2" a
600S250-68	50	11' 10" e	10' 9" e	9' 5" e	13' 3" i	11' 7" i	9' 6" i	10' 9" e	9' 9" e	8' 6" e	12' 1" i	10' 11" i	9' 6" i
600S250-97	50	13' 2" e	11' 11" e	10' 5" e	14' 9" i	13' 5" i	11' 9" i	11' 11" e	10' 10" e	9' 6" e	13' 5" e	12' 2" e	10' 8" i
600S300-54	50	11' 2" e	10' 1" e	8' 3" e	11' 8" i	10' 1" i	8' 3" a	10' 2" e	9' 3" e	8' 1" e	11' 5" i	10' 1" i	8' 3" a
600S300-68	50	12' 3" e	11' 1" e	9' 8" e	13' 8" i	11' 10" i	9' 8" i	11' 1" e	10' 1" e	8' 10" e	12' 6" i	11' 4" i	9' 8" i
600S300-97	50	13' 8" e	12' 5" e	10' 10" e	15' 4" i	13' 11" i	12' 2" i	12' 5" e	11' 3" e	9' 10" e	13' 11" e	12' 8" e	11' 1" i
800S137-33	33	6' 9" e	5' 1" e	3' 5" e	5' 2" a	4' 1" a	2' 8" a	6' 9" e	5' 1" e	3' 5" e	5' 2" a	4' 1" a	2' 8" a
800S137-43	33	8' 6" e	7' 4" e	6' 0" e	8' 5" a	6' 11" a	5' 1" a	8' 6" e	7' 4" e	6' 0" e	8' 5" a	6' 11" a	5' 1" a
800S137-54	50	11' 4" e	9' 10" e	8' 0" e	11' 4" i	9' 10" i	8' 0" a	10' 11" e	9' 10" e	8' 0" e	11' 4" i	9' 10" i	8' 0" a
800S137-68	50	13' 0" e	11' 7" e	9' 5" e	13' 4" i	11' 7" i	9' 5" i	11' 10" e	10' 9" e	9' 5" e	13' 3" i	11' 7" i	9' 5" i
800S137-97	50	14' 5" e	13' 1" e	11' 5" e	16' 2" i	14' 8" i	12' 0" i	13' 1" e	11' 11" e	10' 5" e	14' 9" e	13' 5" i	11' 8" i
800S162-33	33	6' 9" e	5' 1" e	3' 5" e	5' 4" a	4' 1" a	2' 8" a	6' 9" e	5' 1" e	3' 5" e	5' 4" a	4' 1" a	2' 8" a
800S162-43	33	9' 2" e	7' 11" e	6' 6" e	8' 10" a	7' 2" a	5' 4" a	9' 2" e	7' 11" e	6' 6" e	8' 10" a	7' 2" a	5' 4" a
800S162-54	50	12' 3" e	10' 7" e	8' 8" e	12' 3" i	10' 7" i	8' 6" a	11' 4" e	10' 4" e	8' 8" e	12' 3" i	10' 7" i	8' 6" a
800S162-68	50	13' 6" e	12' 3" e	10' 2" e	14' 4" i	12' 5" i	10' 2" i	12' 3" e	11' 2" e	9' 9" e	13' 10" i	12' 5" i	10' 2" i
800S162-97	50	15' 0" e	13' 8" e	11' 11" e	16' 11" i	15' 4" i	12' 10" i	13' 8" e	12' 5" e	10' 10" e	15' 4" e	13' 11" i	12' 2" i

Notes:

- 1 Web punchouts are not considered for shear and web crippling.
- 2 Deflection checks are computed using unbalanced loads for the two equal span conditions.
- 3 "e" indicates that the web stiffeners are required at the end support only.
- 4 "i" indicates that the web stiffeners are required at the interior support only.
- 5 "a" indicates that the web stiffeners are required at all supports.
- 6 See additional floor joist notes on page 62.

Complies with AISI S100-16 (2020) w/S20-2 • IBC 2024

FLOOR JOIST SPAN LIMITATIONS

15psf Dead Load and 125psf Live Load (TL Deflection=L/240)

Member	Yield strength F _y (ksi)	Live Load Deflection L/360						Live Load Deflection L/480					
		Single span spacing (in) o.c.			Two equal span spacing (in) o.c.			Single span spacing (in) o.c.			Two equal span spacing (in) o.c.		
		12	16	24	12	16	24	12	16	24	12	16	24
800S200-33	33	6' 9" e	5' 1" e	3' 5" e	5' 5" a	4' 1" a	2' 8" a	6' 9" e	5' 1" e	3' 5" e	5' 5" a	4' 1" a	2' 8" a
800S200-43	33	9' 10" e	8' 6" e	7' 0" e	9' 3" a	7' 6" a	5' 6" a	9' 10" e	8' 6" e	7' 0" e	9' 3" a	7' 6" a	5' 6" a
800S200-54	50	13' 1" e	11' 4" e	9' 3" e	13' 1" i	11' 4" a	8' 11" a	12' 0" e	10' 11" e	9' 3" e	13' 1" i	11' 4" a	8' 11" a
800S200-68	50	14' 2" e	12' 11" e	10' 10" e	15' 4" i	13' 3" i	10' 10" i	12' 11" e	11' 8" e	10' 3" e	14' 5" i	13' 2" i	10' 10" i
800S200-97	50	15' 9" e	14' 4" e	12' 6" e	17' 8" i	16' 1" i	13' 8" i	14' 4" e	13' 0" e	11' 4" e	16' 1" e	14' 7" i	12' 9" i
800S250-43	33	10' 1" e	8' 9" e	7' 2" e	9' 4" a	7' 7" a	5' 7" a	10' 1" e	8' 9" e	7' 2" e	9' 4" a	7' 7" a	5' 7" a
800S250-54	50	13' 5" e	11' 8" e	9' 6" e	13' 5" i	11' 8" a	9' 0" a	12' 6" e	11' 4" e	9' 6" e	13' 5" i	11' 8" a	9' 0" a
800S250-68	50	14' 9" e	13' 5" e	11' 2" e	15' 9" i	13' 8" i	11' 2" a	13' 5" e	12' 2" e	10' 8" e	15' 1" i	13' 8" i	11' 2" a
800S250-97	50	16' 6" e	15' 0" e	13' 1" e	18' 6" i	16' 10" i	14' 1" i	15' 0" e	13' 7" e	11' 11" e	16' 10" e	15' 3" i	13' 4" i
800S300-54	50	13' 8" e	11' 10" e	9' 8" e	13' 8" i	11' 10" a	9' 1" a	12' 9" e	11' 7" e	9' 8" e	13' 8" i	11' 10" a	9' 1" a
800S300-68	50	15' 3" e	13' 10" e	11' 4" e	16' 0" i	13' 10" i	11' 4" a	13' 10" e	12' 7" e	11' 0" e	15' 6" i	13' 10" i	11' 4" a
800S300-97	50	17' 1" e	15' 6" e	13' 6" e	19' 2" i	17' 5" i	14' 5" i	15' 6" e	14' 1" e	12' 4" e	17' 5" i	15' 10" i	13' 10" i
1000S162-43	33	10' 2" e	8' 10" e	6' 0" e	8' 5" a	6' 9" a	4' 9" a	10' 2" e	8' 10" e	6' 0" e	8' 5" a	6' 9" a	4' 9" a
1000S162-54	50	13' 7" e	11' 10" e	9' 8" e	13' 6" i	11' 0" a	8' 2" a	13' 6" e	11' 10" e	9' 8" e	13' 6" i	11' 0" a	8' 2" a
1000S162-68	50	16' 1" e	13' 11" e	11' 4" e	16' 1" i	13' 11" i	11' 4" a	14' 8" e	13' 4" e	11' 4" e	16' 1" i	13' 11" i	11' 4" a
1000S162-97	50	18' 1" e	16' 5" e	14' 4" e	20' 4" i	17' 10" i	14' 6" i	16' 5" e	14' 11" e	13' 1" e	18' 6" i	16' 9" i	14' 6" i
1000S200-43	33	11' 0" e	8' 11" e	6' 0" e	8' 9" a	7' 0" a	4' 9" a	11' 0" e	8' 11" e	6' 0" e	8' 9" a	7' 0" a	4' 9" a
1000S200-54	50	14' 8" e	12' 9" e	10' 5" e	14' 1" a	11' 6" a	8' 6" a	14' 2" e	12' 9" e	10' 5" e	14' 1" a	11' 6" a	8' 6" a
1000S200-68	50	16' 10" e	14' 11" e	12' 2" e	17' 3" i	14' 11" i	12' 2" a	15' 4" e	13' 11" e	12' 2" e	17' 2" i	14' 11" i	12' 2" a
1000S200-97	50	18' 11" e	17' 2" e	15' 0" e	21' 3" i	19' 0" i	15' 6" i	17' 2" e	15' 7" e	13' 8" e	19' 3" i	17' 6" i	15' 4" i
1000S250-54	50	15' 1" e	13' 1" e	10' 8" e	14' 4" a	11' 8" a	8' 7" a	14' 11" e	13' 1" e	10' 8" e	14' 4" a	11' 8" a	8' 7" a
1000S250-68	50	17' 8" e	15' 4" e	12' 7" e	17' 9" i	15' 4" i	12' 7" a	16' 0" e	14' 7" e	12' 7" e	17' 9" i	15' 4" i	12' 7" a
1000S250-97	50	19' 8" e	17' 11" e	15' 8" e	22' 1" i	19' 7" i	16' 0" i	17' 11" e	16' 3" e	14' 2" e	20' 1" i	18' 3" i	15' 11" i
1000S300-54	50	15' 4" e	13' 3" e	10' 10" e	14' 5" a	11' 9" a	8' 8" a	15' 3" e	13' 3" e	10' 10" e	14' 5" a	11' 9" a	8' 8" a
1000S300-68	50	18' 0" e	15' 7" e	12' 9" e	18' 0" i	15' 7" i	12' 9" a	16' 6" e	15' 0" e	12' 9" e	18' 0" i	15' 7" i	12' 9" a
1000S300-97	50	20' 4" e	18' 5" e	16' 1" e	22' 10" i	20' 0" i	16' 4" i	18' 5" e	16' 9" e	14' 8" e	20' 9" i	18' 10" i	16' 4" i
1200S162-54	50	14' 8" e	12' 9" e	9' 10" e	13' 0" a	10' 6" a	7' 7" a	14' 8" e	12' 9" e	9' 10" e	13' 0" a	10' 6" a	7' 7" a
1200S162-68	50	17' 5" e	15' 1" e	12' 4" e	17' 5" i	15' 1" i	11' 10" a	16' 11" e	15' 1" e	12' 4" e	17' 5" i	15' 1" i	11' 10" a
1200S162-97	50	21' 1" e	19' 2" e	15' 11" e	22' 6" i	19' 6" i	15' 11" i	19' 2" e	17' 5" e	15' 2" e	21' 6" i	19' 6" i	15' 11" i
1200S200-54	50	15' 11" e	13' 10" e	9' 10" e	13' 7" a	10' 11" a	7' 10" a	15' 11" e	13' 10" e	9' 10" e	13' 7" a	10' 11" a	7' 10" a
1200S200-68	50	18' 10" e	16' 4" e	13' 4" e	18' 10" i	16' 4" a	12' 4" a	17' 7" e	16' 0" e	13' 4" e	18' 10" i	16' 4" a	12' 4" a
1200S200-97	50	21' 11" e	19' 11" e	17' 1" e	24' 2" i	20' 11" i	17' 1" i	19' 11" e	18' 1" e	15' 10" e	22' 4" i	20' 4" i	17' 1" i

Notes:

- 1 Web punchouts are not considered for shear and web crippling.
- 2 Deflection checks are computed using unbalanced loads for the two equal span conditions.
- 3 "e" indicates that the web stiffeners are required at the end support only.
- 4 "i" indicates that the web stiffeners are required at the interior support only.
- 5 "a" indicates that the web stiffeners are required at all supports.
- 6 See additional floor joist notes on page 62.

Complies with AISI S100-16 (2020) w/S20-20 • IBC 2024

The technical content of this literature is effective 06/01/24 and supersedes all previous information.

FLOOR JOIST SPAN LIMITATIONS

15psf Dead Load and 125psf Live Load (TL Deflection=L/240)

Member	Yield strength F _y (ksi)	Live Load Deflection L/360						Live Load Deflection L/480					
		Single span spacing (in) o.c.			Two equal span spacing (in) o.c.			Single span spacing (in) o.c.			Two equal span spacing (in) o.c.		
		12	16	24	12	16	24	12	16	24	12	16	24
1200S250-54	50	16' 6" e	14' 3" e	9' 10" e	13' 9" a	11' 1" a	7' 10" a	16' 6" e	14' 3" e	9' 10" e	13' 9" a	11' 1" a	7' 10" a
1200S250-68	50	19' 5" e	16' 10" e	13' 9" e	19' 5" i	16' 9" a	12' 7" a	18' 4" e	16' 8" e	13' 9" e	19' 5" i	16' 9" a	12' 7" a
1200S250-97	50	22' 9" e	20' 8" e	17' 8" e	25' 0" i	21' 8" i	17' 8" i	20' 8" e	18' 10" e	16' 5" e	23' 3" i	21' 1" i	17' 8" i
1200S300-54	50	16' 9" e	14' 6" e	9' 10" e	13' 11" a	11' 2" a	7' 10" a	16' 9" e	14' 6" e	9' 10" e	13' 11" a	11' 2" a	7' 10" a
1200S300-68	50	19' 10" e	17' 2" e	14' 0" e	19' 10" i	16' 11" a	12' 9" a	19' 1" e	17' 2" e	14' 0" e	19' 10" i	16' 11" a	12' 9" a
1200S300-97	50	23' 6" e	21' 4" e	18' 1" e	25' 6" i	22' 1" i	18' 1" i	21' 4" e	19' 5" e	16' 11" e	24' 0" i	21' 9" i	18' 1" i
1400S162-54	50	15' 6" e	12' 7" e	8' 5" e	12' 4" a	9' 10" a	6' 9" a	15' 6" e	12' 7" e	8' 5" e	12' 4" a	9' 10" a	6' 9" a
1400S162-68	50	18' 6" e	16' 0" e	13' 1" e	18' 6" i	15' 3" a	11' 4" a	18' 6" e	16' 0" e	13' 1" e	18' 6" i	15' 3" a	11' 4" a
1400S162-97	50	23' 10" e	20' 11" e	17' 1" e	24' 2" i	20' 11" i	17' 1" i	21' 8" e	19' 8" e	17' 1" e	24' 2" i	20' 11" i	17' 1" i
1400S200-54	50	16' 10" e	12' 7" e	8' 5" e	12' 10" a	10' 1" a	6' 9" a	16' 10" e	12' 7" e	8' 5" e	12' 10" a	10' 1" a	6' 9" a
1400S200-68	50	20' 1" e	17' 5" e	14' 2" e	19' 8" i	16' 0" a	11' 11" a	19' 10" e	17' 5" e	14' 2" e	19' 8" i	16' 0" a	11' 11" a
1400S200-97	50	24' 10" e	22' 6" e	18' 5" e	26' 0" i	22' 7" i	18' 5" i	22' 6" e	20' 6" e	17' 11" e	25' 4" i	22' 7" i	18' 5" i
1400S250-54	50	16' 10" e	12' 7" e	8' 5" e	13' 0" a	10' 1" a	6' 9" a	16' 10" e	12' 7" e	8' 5" e	13' 0" a	10' 1" a	6' 9" a
1400S250-68	50	20' 10" e	18' 1" e	14' 9" e	20' 1" a	16' 4" a	12' 1" a	20' 8" e	18' 1" e	14' 9" e	20' 1" a	16' 4" a	12' 1" a
1400S250-97	50	25' 9" e	23' 4" e	19' 1" e	27' 0" i	23' 5" i	19' 1" a	23' 4" e	21' 3" e	18' 7" e	26' 3" i	23' 5" i	19' 1" a
1400S300-54	50	16' 10" e	12' 7" e	8' 5" e	13' 2" a	10' 1" a	6' 9" a	16' 10" e	12' 7" e	8' 5" e	13' 2" a	10' 1" a	6' 9" a
1400S300-68	50	21' 4" e	18' 6" e	15' 1" e	20' 4" a	16' 6" a	12' 3" a	21' 2" e	18' 6" e	15' 1" e	20' 4" a	16' 6" a	12' 3" a
1400S300-97	50	26' 6" e	23' 11" e	19' 7" e	27' 8" i	23' 11" i	19' 7" a	24' 1" e	21' 11" e	19' 1" e	27' 0" i	23' 11" i	19' 7" a

Notes:

- 1 Web punchouts are not considered for shear and web crippling.
- 2 Deflection checks are computed using unbalanced loads for the two equal span conditions.
- 3 "e" indicates that the web stiffeners are required at the end support only.
- 4 "i" indicates that the web stiffeners are required at the interior support only.
- 5 "a" indicates that the web stiffeners are required at all supports.
- 6 See additional floor joist notes on page 62.

Complies with AISI S100-16 (2020) w/S2-20 • IBC 2024

The technical content of this literature is effective 06/01/24 and supersedes all previous information.

FLOOR JOIST SPAN LIMITATIONS

25psf Dead Load and 125psf Live Load (TL Deflection=L/240)

Member	Yield strength Fy (ksi)	Live Load Deflection L/360						Live Load Deflection L/480					
		Single span spacing (in) o.c.			Two equal span spacing (in) o.c.			Single span spacing (in) o.c.			Two equal span spacing (in) o.c.		
		12	16	24	12	16	24	12	16	24	12	16	24
600S137-33	33	5' 11" e	5' 1" e	4' 2" e	5' 5" a	4' 4" a	3' 2" a	5' 11" e	5' 1" e	4' 2" e	5' 5" a	4' 4" a	3' 2" a
600S137-43	33	7' 1" e	6' 2" e	5' 0" e	7' 1" a	6' 2" a	5' 0" a	7' 1" e	6' 2" e	5' 0" e	7' 1" a	6' 2" a	5' 0" a
600S137-54	50	9' 5"	8' 2"	6' 8" e	9' 5" i	8' 2" i	6' 8" i	8' 8"	7' 11"	6' 8" e	9' 5" i	8' 2" i	6' 8" i
600S137-68	50	10' 3"	9' 4"	7' 9"	11' 0" i	9' 6" i	7' 9" i	9' 4"	8' 6"	7' 5"	10' 6" i	9' 6" i	7' 9" i
600S137-97	50	11' 4"	10' 4"	9' 0"	12' 9" i	11' 7" i	9' 7" i	10' 4"	9' 4"	8' 2"	11' 7"	10' 6"	9' 2" i
600S162-33	33	6' 4" e	5' 6" e	4' 3" e	5' 7" a	4' 6" a	3' 3" a	6' 4" e	5' 6" e	4' 3" e	5' 7" a	4' 6" a	3' 3" a
600S162-43	33	7' 7" e	6' 7" e	5' 5" e	7' 7" a	6' 7" a	5' 4" a	7' 7" e	6' 7" e	5' 5" e	7' 7" a	6' 7" a	5' 4" a
600S162-54	50	10' 0"	8' 9"	7' 2" e	10' 2" i	8' 9" i	7' 2" a	9' 1"	8' 3"	7' 2" e	10' 2" i	8' 9" i	7' 2" a
600S162-68	50	10' 9"	9' 9"	8' 4"	11' 9" i	10' 3" i	8' 4" i	9' 9"	8' 10"	7' 9"	10' 11" i	9' 11" i	8' 4" i
600S162-97	50	11' 11"	10' 10"	9' 5"	13' 4" i	12' 1" i	10' 3" i	10' 10"	9' 10"	8' 7"	12' 1"	11' 0"	9' 7" i
600S200-33	33	6' 10" e	5' 11" e	4' 3" e	5' 10" a	4' 8" a	3' 5" a	6' 10" e	5' 11" e	4' 3" e	5' 10" a	4' 8" a	3' 5" a
600S200-43	33	8' 2" e	7' 1" e	5' 9" e	8' 2" a	7' 1" a	5' 7" a	8' 2" e	7' 1" e	5' 9" e	8' 2" a	7' 1" a	5' 7" a
600S200-54	50	10' 6"	9' 5" e	7' 8" e	10' 10" i	9' 5" i	7' 8" a	9' 7"	8' 8"	7' 7" e	10' 9" i	9' 5" i	7' 8" a
600S200-68	50	11' 3"	10' 3"	8' 11"	12' 7" i	10' 11" i	8' 11" i	10' 3"	9' 4"	8' 2"	11' 6" i	10' 5" i	8' 11" i
600S200-97	50	12' 6"	11' 4"	9' 11"	14' 1"	12' 9" i	11' 1" i	11' 4"	10' 4"	9' 0"	12' 9"	11' 7"	10' 2" i
600S250-43	33	8' 4" e	7' 3" e	5' 11" e	8' 4" a	7' 3" a	5' 7" a	8' 4" e	7' 3" e	5' 11" e	8' 4" a	7' 3" a	5' 7" a
600S250-54	50	11' 0"	9' 7" e	7' 10" e	11' 1" i	9' 7" i	7' 10" a	9' 11"	9' 1"	7' 10" e	11' 1" i	9' 7" i	7' 10" a
600S250-68	50	11' 10"	10' 9"	9' 2" e	12' 11" i	11' 3" i	9' 2" i	10' 9"	9' 9"	8' 6"	12' 1" i	10' 11" i	9' 2" i
600S250-97	50	13' 2"	11' 11"	10' 5"	14' 9" i	13' 5" i	11' 6" i	11' 11"	10' 10"	9' 6"	13' 5" i	12' 2" i	10' 8" i
600S300-54	50	11' 2"	9' 9" e	8' 0" e	11' 3" i	9' 9" i	8' 0" a	10' 2"	9' 3" e	8' 0" e	11' 3" i	9' 9" i	8' 0" a
600S300-68	50	12' 3"	11' 1"	9' 4" e	13' 2" i	11' 5" i	9' 4" i	11' 1"	10' 1"	8' 10"	12' 6" i	11' 4" i	9' 4" i
600S300-97	50	13' 8"	12' 5"	10' 10"	15' 4" i	13' 11" i	11' 9" i	12' 5"	11' 3"	9' 10"	13' 11" i	12' 8" i	11' 1" i
800S137-33	33	6' 4" e	4' 9" e	3' 2" e	4' 11" a	3' 9" a	2' 6" a	6' 4" e	4' 9" e	3' 2" e	4' 11" a	3' 9" a	2' 6" a
800S137-43	33	8' 2" e	7' 1" e	5' 10" e	8' 0" a	6' 7" a	4' 10" a	8' 2" e	7' 1" e	5' 10" e	8' 0" a	6' 7" a	4' 10" a
800S137-54	50	10' 11"	9' 6" e	7' 9" e	10' 11" i	9' 6" i	7' 9" a	10' 11"	9' 6" e	7' 9" e	10' 11" i	9' 6" i	7' 9" a
800S137-68	50	12' 11"	11' 2"	9' 1" e	12' 11" i	11' 2" i	9' 1" i	11' 10"	10' 9"	9' 1" e	12' 11" i	11' 2" i	9' 1" i
800S137-97	50	14' 5"	13' 1"	11' 5"	16' 2" i	14' 2" i	11' 7" i	13' 1"	11' 11"	10' 5"	14' 9" i	13' 5" i	11' 7" i
800S162-33	33	6' 4" e	4' 9" e	3' 2" e	5' 1" a	3' 9" a	2' 6" a	6' 4" e	4' 9" e	3' 2" e	5' 1" a	3' 9" a	2' 6" a
800S162-43	33	8' 10" e	7' 8" e	6' 3" e	8' 5" a	6' 10" a	5' 1" a	8' 10" e	7' 8" e	6' 3" e	8' 5" a	6' 10" a	5' 1" a
800S162-54	50	11' 10" e	10' 3" e	8' 4" e	11' 10" i	10' 3" a	8' 1" a	11' 4"	10' 3" e	8' 4" e	11' 10" i	10' 3" a	8' 1" a
800S162-68	50	13' 6"	12' 0"	9' 10" e	13' 10" i	12' 0" i	9' 10" i	12' 3"	11' 2"	9' 9" e	13' 10" i	12' 0" i	9' 10" i
800S162-97	50	15' 0"	13' 8"	11' 11"	16' 11" i	15' 2" i	12' 4" i	13' 8"	12' 5"	10' 10"	15' 4" i	13' 11" i	12' 2" i

Notes:

- 1 Web punchouts are not considered for shear and web crippling.
- 2 Deflection checks are computed using unbalanced loads for the two equal span conditions.
- 3 "e" indicates that the web stiffeners are required at the end support only.
- 4 "i" indicates that the web stiffeners are required at the interior support only.
- 5 "a" indicates that the web stiffeners are required at all supports.
- 6 See additional floor joist notes on page 62.

Complies with AISI S100-16 (2020) w/S20-2 • IBC 2024

The technical content of this literature is effective 06/01/24 and supersedes all previous information.

FLOOR JOIST SPAN LIMITATIONS

25psf Dead Load and 125psf Live Load (TL Deflection=L/240)

Member	Yield strength F _y (ksi)	Live Load Deflection L/360						Live Load Deflection L/480					
		Single span spacing (in) o.c.			Two equal span spacing (in) o.c.			Single span spacing (in) o.c.			Two equal span spacing (in) o.c.		
		12	16	24	12	16	24	12	16	24	12	16	24
800S200-33	33	6' 4" e	4' 9" e	3' 2" e	5' 1" a	3' 9" a	2' 6" a	6' 4" e	4' 9" e	3' 2" e	5' 1" a	3' 9" a	2' 6" a
800S200-43	33	9' 6" e	8' 3" e	6' 9" e	8' 9" a	7' 1" a	5' 3" a	9' 6" e	8' 3" e	6' 9" e	8' 9" a	7' 1" a	5' 3" a
800S200-54	50	12' 8" e	11' 0" e	9' 0" e	12' 8" i	11' 0" a	8' 6" a	12' 0" e	10' 11" e	9' 0" e	12' 8" i	11' 0" a	8' 6" a
800S200-68	50	14' 2" e	12' 10" e	10' 6" e	14' 10" i	12' 10" i	10' 6" a	12' 11" e	11' 8" e	10' 3" e	14' 5" i	12' 10" i	10' 6" a
800S200-97	50	15' 9" e	14' 4" e	12' 6" e	17' 8" i	16' 1" i	13' 2" i	14' 4" e	13' 0" e	11' 4" e	16' 1" i	14' 7" i	12' 9" i
800S250-43	33	9' 9" e	8' 6" e	6' 11" e	8' 11" a	7' 2" a	5' 3" a	9' 9" e	8' 6" e	6' 11" e	8' 11" a	7' 2" a	5' 3" a
800S250-54	50	13' 0" e	11' 3" e	9' 2" e	13' 0" i	11' 3" a	8' 7" a	12' 6" e	11' 3" e	9' 2" e	13' 0" i	11' 3" a	8' 7" a
800S250-68	50	14' 9" e	13' 2" e	10' 9" e	15' 2" i	13' 2" i	10' 9" a	13' 5" e	12' 2" e	10' 8" e	15' 1" i	13' 2" i	10' 9" a
800S250-97	50	16' 6" e	15' 0" e	13' 1" e	18' 6" i	16' 8" i	13' 7" i	15' 0" e	13' 7" e	11' 11" e	16' 10" i	15' 3" i	13' 4" i
800S300-54	50	13' 2" e	11' 5" e	9' 4" e	13' 2" i	11' 5" a	8' 8" a	12' 9" e	11' 5" e	9' 4" e	13' 2" i	11' 5" a	8' 8" a
800S300-68	50	15' 3" e	13' 5" e	10' 11" e	15' 5" i	13' 5" i	10' 11" a	13' 10" e	12' 7" e	10' 11" e	15' 5" i	13' 5" i	10' 11" a
800S300-97	50	17' 1" e	15' 6" e	13' 6" e	19' 2" i	17' 0" i	13' 11" i	15' 6" e	14' 1" e	12' 4" e	17' 5" i	15' 10" i	13' 10" i
1000S162-43	33	9' 10" e	8' 4" e	5' 7" e	8' 0" a	6' 5" a	4' 5" a	9' 10" e	8' 4" e	5' 7" e	8' 0" a	6' 5" a	4' 5" a
1000S162-54	50	13' 2" e	11' 5" e	9' 4" e	12' 10" i	10' 6" a	7' 9" a	13' 2" e	11' 5" e	9' 4" e	12' 10" i	10' 6" a	7' 9" a
1000S162-68	50	15' 6" e	13' 5" e	11' 0" e	15' 6" i	13' 5" i	11' 0" a	14' 8" e	13' 4" e	11' 0" e	15' 6" i	13' 5" i	11' 0" a
1000S162-97	50	18' 1" e	16' 5" e	14' 0" e	19' 10" i	17' 2" i	14' 0" i	16' 5" e	14' 11" e	13' 1" e	18' 6" i	16' 9" i	14' 0" i
1000S200-43	33	10' 8" e	8' 4" e	5' 7" e	8' 3" a	6' 7" a	4' 5" a	10' 8" e	8' 4" e	5' 7" e	8' 3" a	6' 7" a	4' 5" a
1000S200-54	50	14' 2" e	12' 3" e	10' 0" e	13' 5" a	10' 11" a	8' 1" a	14' 2" e	12' 3" e	10' 0" e	13' 5" a	10' 11" a	8' 1" a
1000S200-68	50	16' 8" e	14' 5" e	11' 9" e	16' 8" i	14' 5" i	11' 9" a	15' 4" e	13' 11" e	11' 9" e	16' 8" i	14' 5" i	11' 9" a
1000S200-97	50	18' 11" e	17' 2" e	15' 0" e	21' 3" i	18' 4" i	15' 0" i	17' 2" e	15' 7" e	13' 8" e	19' 3" i	17' 6" i	15' 0" i
1000S250-54	50	14' 7" e	12' 7" e	10' 4" e	13' 8" a	11' 1" a	8' 2" a	14' 7" e	12' 7" e	10' 4" e	13' 8" a	11' 1" a	8' 2" a
1000S250-68	50	17' 2" e	14' 10" e	12' 1" e	17' 2" i	14' 10" i	12' 1" a	16' 0" e	14' 7" e	12' 1" e	17' 2" i	14' 10" i	12' 1" a
1000S250-97	50	19' 8" e	17' 11" e	15' 6" e	21' 10" i	18' 11" i	15' 6" i	17' 11" e	16' 3" e	14' 2" e	20' 1" i	18' 3" i	15' 6" i
1000S300-54	50	14' 10" e	12' 10" e	10' 6" e	13' 9" a	11' 2" a	8' 2" a	14' 10" e	12' 10" e	10' 6" e	13' 9" a	11' 2" a	8' 2" a
1000S300-68	50	17' 5" e	15' 1" e	12' 4" e	17' 5" i	15' 1" a	12' 4" a	16' 6" e	15' 0" e	12' 4" e	17' 5" i	15' 1" a	12' 4" a
1000S300-97	50	20' 4" e	18' 5" e	15' 9" e	22' 4" i	19' 4" i	15' 9" i	18' 5" e	16' 9" e	14' 8" e	20' 9" i	18' 10" i	15' 9" i
1200S162-54	50	14' 2" e	12' 3" e	9' 2" e	12' 4" a	9' 11" a	7' 3" a	14' 2" e	12' 3" e	9' 2" e	12' 4" a	9' 11" a	7' 3" a
1200S162-68	50	16' 10" e	14' 7" e	11' 11" e	16' 10" i	14' 7" a	11' 3" a	16' 10" e	14' 7" e	11' 11" e	16' 10" i	14' 7" a	11' 3" a
1200S162-97	50	21' 1" e	18' 10" e	15' 5" e	21' 9" i	18' 10" i	15' 5" i	19' 2" e	17' 5" e	15' 2" e	21' 6" i	18' 10" i	15' 5" i
1200S200-54	50	15' 5" e	13' 4" e	9' 2" e	12' 11" a	10' 4" a	7' 4" a	15' 5" e	13' 4" e	9' 2" e	12' 11" a	10' 4" a	7' 4" a
1200S200-68	50	18' 2" e	15' 9" e	12' 10" e	18' 2" i	15' 7" a	11' 9" a	17' 7" e	15' 9" e	12' 10" e	18' 2" i	15' 7" a	11' 9" a
1200S200-97	50	21' 11" e	19' 11" e	16' 6" e	23' 4" i	20' 3" i	16' 6" i	19' 11" e	18' 1" e	15' 10" e	22' 4" i	20' 3" i	16' 6" i

Notes:

- 1 Web punchouts are not considered for shear and web crippling.
- 2 Deflection checks are computed using unbalanced loads for the two equal span conditions.
- 3 "e" indicates that the web stiffeners are required at the end support only.
- 4 "i" indicates that the web stiffeners are required at the interior support only.
- 5 "a" indicates that the web stiffeners are required at all supports.
- 6 See additional floor joist notes on page 62.

Complies with AISI S100-16 (2020) w/S20-0 • IBC 2024

FLOOR JOIST SPAN LIMITATIONS

25psf Dead Load and 125psf Live Load (TL Deflection=L/240)

Member	Yield strength F _y (ksi)	Live Load Deflection L/360						Live Load Deflection L/480					
		Single span spacing (in) o.c.			Two equal span spacing (in) o.c.			Single span spacing (in) o.c.			Two equal span spacing (in) o.c.		
		12	16	24	12	16	24	12	16	24	12	16	24
1200S250-54	50	15' 11" e	13' 9" e	9' 2" e	13' 1" a	10' 6" a	7' 4" a	15' 11" e	13' 9" e	9' 2" e	13' 1" a	10' 6" a	7' 4" a
1200S250-68	50	18' 9" e	16' 3" e	13' 3" e	18' 9" i	16' 0" a	11' 11" a	18' 4" e	16' 3" e	13' 3" e	18' 9" i	16' 0" a	11' 11" a
1200S250-97	50	22' 9" e	20' 8" e	17' 1" e	24' 2" i	20' 11" i	17' 1" i	20' 8" e	18' 10" e	16' 5" e	23' 3" i	20' 11" i	17' 1" i
1200S300-54	50	16' 3" e	13' 9" e	9' 2" e	13' 2" a	10' 7" a	7' 4" a	16' 3" e	13' 9" e	9' 2" e	13' 2" a	10' 7" a	7' 4" a
1200S300-68	50	19' 2" e	16' 7" e	13' 6" e	19' 2" i	16' 2" a	12' 1" a	19' 1" e	16' 7" e	13' 6" e	19' 2" i	16' 2" a	12' 1" a
1200S300-97	50	23' 6" e	21' 4" e	17' 5" e	24' 8" i	21' 4" i	17' 5" i	21' 4" e	19' 5" e	16' 11" e	24' 0" i	21' 4" i	17' 5" i
1400S162-54	50	15' 0" e	11' 9" e	7' 10" e	11' 8" a	9' 3" a	6' 3" a	15' 0" e	11' 9" e	7' 10" e	11' 8" a	9' 3" a	6' 3" a
1400S162-68	50	17' 10" e	15' 6" e	12' 8" e	17' 9" i	14' 6" a	10' 10" a	17' 10" e	15' 6" e	12' 8" e	17' 9" i	14' 6" a	10' 10" a
1400S162-97	50	23' 4" e	20' 2" e	16' 6" e	23' 4" i	20' 2" i	16' 6" i	21' 8" e	19' 8" e	16' 6" e	23' 4" i	20' 2" i	16' 6" i
1400S200-54	50	15' 8" e	11' 9" e	7' 10" e	12' 2" a	9' 5" a	6' 3" a	15' 8" e	11' 9" e	7' 10" e	12' 2" a	9' 5" a	6' 3" a
1400S200-68	50	19' 5" e	16' 10" e	13' 9" e	18' 8" i	15' 3" a	11' 3" a	19' 5" e	16' 10" e	13' 9" e	18' 8" i	15' 3" a	11' 3" a
1400S200-97	50	24' 10" e	21' 9" e	17' 9" e	25' 2" i	21' 9" i	17' 9" i	22' 6" e	20' 6" e	17' 9" e	25' 2" i	21' 9" i	17' 9" i
1400S250-54	50	15' 8" e	11' 9" e	7' 10" e	12' 4" a	9' 5" a	6' 3" a	15' 8" e	11' 9" e	7' 10" e	12' 4" a	9' 5" a	6' 3" a
1400S250-68	50	20' 2" e	17' 5" e	14' 3" e	19' 1" a	15' 6" a	11' 5" a	20' 2" e	17' 5" e	14' 3" e	19' 1" a	15' 6" a	11' 5" a
1400S250-97	50	25' 9" e	22' 7" e	18' 5" e	26' 1" i	22' 7" i	18' 5" a	23' 4" e	21' 3" e	18' 5" e	26' 1" i	22' 7" i	18' 5" a
1400S300-54	50	15' 8" e	11' 9" e	7' 10" e	12' 5" a	9' 5" a	6' 3" a	15' 8" e	11' 9" e	7' 10" e	12' 5" a	9' 5" a	6' 3" a
1400S300-68	50	20' 8" e	17' 10" e	14' 7" e	19' 5" a	15' 9" a	11' 7" a	20' 8" e	17' 10" e	14' 7" e	19' 5" a	15' 9" a	11' 7" a
1400S300-97	50	26' 6" e	23' 2" e	18' 11" e	26' 9" i	23' 2" i	18' 11" a	24' 1" e	21' 11" e	18' 11" e	26' 9" i	23' 2" i	18' 11" a

Notes:

- 1 Web punchouts are not considered for shear and web crippling.
- 2 Deflection checks are computed using unbalanced loads for the two equal span conditions.
- 3 "e" indicates that the web stiffeners are required at the end support only.
- 4 "i" indicates that the web stiffeners are required at the interior support only.
- 5 "a" indicates that the web stiffeners are required at all supports.
- 6 See additional floor joist notes on page 62.

Complies with AISI S100-16 (2020) w/S2-20 • IBC 2024

The technical content of this literature is effective 06/01/24 and supersedes all previous information.

FLOOR JOIST SPAN LIMITATIONS

40psf Dead Load and 125psf Live Load (TL Deflection=L/240)

Member	Yield strength F _y (ksi)	Live Load Deflection L/360						Live Load Deflection L/480					
		Single span spacing (in) o.c.			Two equal span spacing (in) o.c.			Single span spacing (in) o.c.			Two equal span spacing (in) o.c.		
		12	16	24	12	16	24	12	16	24	12	16	24
600S137-33	33	5' 7" e	4' 10" e	3' 10" e	5' 0" a	4' 1" a	3' 0" a	5' 7" e	4' 10" e	3' 10" e	5' 0" a	4' 1" a	3' 0" a
600S137-43	33	6' 9" e	5' 10" e	4' 9" e	6' 9" a	5' 10" a	4' 9" a	6' 9" e	5' 10" e	4' 9" e	6' 9" a	5' 10" a	4' 9" a
600S137-54	50	9' 0"	7' 10"	6' 4" e	9' 0" i	7' 10" i	6' 4" i	8' 8"	7' 10"	6' 4" e	9' 0" i	7' 10" i	6' 4" i
600S137-68	50	10' 3"	9' 1"	7' 5"	10' 6" i	9' 1" i	7' 5" i	9' 4"	8' 6"	7' 5"	10' 6" i	9' 1" i	7' 5" i
600S137-97	50	11' 4"	10' 4"	9' 0"	12' 9" i	11' 3" i	9' 2" i	10' 4"	9' 4"	8' 2"	11' 7"	10' 6" i	9' 2" i
600S162-33	33	6' 1" e	5' 3" e	3' 10" e	5' 3" a	4' 3" a	3' 1" a	6' 1" e	5' 3" e	3' 10" e	5' 3" a	4' 3" a	3' 1" a
600S162-43	33	7' 3" e	6' 3" e	5' 2" e	7' 3" a	6' 3" a	5' 0" a	7' 3" e	6' 3" e	5' 2" e	7' 3" a	6' 3" a	5' 0" a
600S162-54	50	9' 8"	8' 5" e	6' 10" e	9' 8" i	8' 5" i	6' 10" a	9' 1"	8' 3"	6' 10" e	9' 8" i	8' 5" i	6' 10" a
600S162-68	50	10' 9"	9' 9"	7' 11"	11' 3" i	9' 9" i	7' 11" i	9' 9"	8' 10"	7' 9"	10' 11" i	9' 9" i	7' 11" i
600S162-97	50	11' 11"	10' 10"	9' 5"	13' 4" i	12' 0" i	9' 10" i	10' 10"	9' 10"	8' 7"	12' 1"	11' 0" i	9' 7" i
600S200-33	33	6' 6" e	5' 8" e	3' 10" e	5' 5" a	4' 4" a	3' 1" a	6' 6" e	5' 8" e	3' 10" e	5' 5" a	4' 4" a	3' 1" a
600S200-43	33	7' 9" e	6' 9" e	5' 6" e	7' 9" a	6' 9" a	5' 2" a	7' 9" e	6' 9" e	5' 6" e	7' 9" a	6' 9" a	5' 2" a
600S200-54	50	10' 4"	8' 11" e	7' 4" e	10' 4" i	8' 11" i	7' 4" a	9' 7"	8' 8" e	7' 4" e	10' 4" i	8' 11" i	7' 4" a
600S200-68	50	11' 3"	10' 3"	8' 6" e	12' 0" i	10' 5" i	8' 6" i	10' 3"	9' 4"	8' 2"	11' 6" i	10' 5" i	8' 6" i
600S200-97	50	12' 6"	11' 4"	9' 11"	14' 1" i	12' 9" i	10' 7" i	11' 4"	10' 4"	9' 0"	12' 9"	11' 7" i	10' 2" i
600S250-43	33	8' 0" e	6' 11" e	5' 8" e	8' 0" a	6' 11" a	5' 3" a	8' 0" e	6' 11" e	5' 8" e	8' 0" a	6' 11" a	5' 3" a
600S250-54	50	10' 7"	9' 2" e	7' 6" e	10' 7" i	9' 2" i	7' 6" a	9' 11"	9' 1" e	7' 6" e	10' 7" i	9' 2" i	7' 6" a
600S250-68	50	11' 10"	10' 8"	8' 9" e	12' 4" i	10' 8" i	8' 9" i	10' 9"	9' 9"	8' 6" e	12' 1" i	10' 8" i	8' 9" i
600S250-97	50	13' 2"	11' 11"	10' 5"	14' 9" i	13' 5" i	10' 11" i	11' 11"	10' 10"	9' 6"	13' 5"	12' 2" i	10' 8" i
600S300-54	50	10' 9"	9' 4" e	7' 7" e	10' 9" i	9' 4" i	7' 7" a	10' 2"	9' 3" e	7' 7" e	10' 9" i	9' 4" i	7' 7" a
600S300-68	50	12' 3"	10' 11"	8' 11" e	12' 7" i	10' 11" i	8' 11" i	11' 1"	10' 1"	8' 10" e	12' 6" i	10' 11" i	8' 11" i
600S300-97	50	13' 8"	12' 5"	10' 10"	15' 4" i	13' 9" i	11' 3" i	12' 5"	11' 3"	9' 10"	13' 11"	12' 8" i	11' 1" i
800S137-33	33	5' 9" e	4' 4" e	2' 10" e	4' 7" a	3' 5" a	2' 4" a	5' 9" e	4' 4" e	2' 10" e	4' 7" a	3' 5" a	2' 4" a
800S137-43	33	7' 10" e	6' 9" e	5' 6" e	7' 6" a	6' 2" a	4' 6" a	7' 10" e	6' 9" e	5' 6" e	7' 6" a	6' 2" a	4' 6" a
800S137-54	50	10' 5"	9' 1" e	7' 5" e	10' 5" i	9' 1" i	7' 3" a	10' 5"	9' 1" e	7' 5" e	10' 5" i	9' 1" i	7' 3" a
800S137-68	50	12' 4"	10' 8"	8' 8" e	12' 4" i	10' 8" i	8' 8" i	11' 10"	10' 8"	8' 8" e	12' 4" i	10' 8" i	8' 8" i
800S137-97	50	14' 5"	13' 1"	11' 0"	15' 7" i	13' 6" i	11' 0" i	13' 1"	11' 11"	10' 5"	14' 9" i	13' 5" i	11' 0" i
800S162-33	33	5' 9" e	4' 4" e	2' 10" e	4' 7" a	3' 5" a	2' 4" a	5' 9" e	4' 4" e	2' 10" e	4' 7" a	3' 5" a	2' 4" a
800S162-43	33	8' 6" e	7' 4" e	6' 0" e	7' 11" a	6' 5" a	4' 9" a	8' 6" e	7' 4" e	6' 0" e	7' 11" a	6' 5" a	4' 9" a
800S162-54	50	11' 3" e	9' 9" e	8' 0" e	11' 3" i	9' 9" a	7' 7" a	11' 3" e	9' 9" e	8' 0" e	11' 3" i	9' 9" a	7' 7" a
800S162-68	50	13' 3"	11' 5"	9' 4" e	13' 3" i	11' 5" i	9' 4" i	12' 3"	11' 2"	9' 4" e	13' 3" i	11' 5" i	9' 4" i
800S162-97	50	15' 0"	13' 8"	11' 10"	16' 8" i	14' 5" i	11' 10" i	13' 8"	12' 5"	10' 10"	15' 4" i	13' 11" i	11' 10" i

Notes:

- 1 Web punchouts are not considered for shear and web crippling.
- 2 Deflection checks are computed using unbalanced loads for the two equal span conditions.
- 3 "e" indicates that the web stiffeners are required at the end support only.
- 4 "i" indicates that the web stiffeners are required at the interior support only.
- 5 "a" indicates that the web stiffeners are required at all supports.
- 6 See additional floor joist notes on page 62.

Complies with AISI S100-16 (2020) w/S20-2 • IBC 2024

FLOOR JOIST SPAN LIMITATIONS

40psf Dead Load and 125psf Live Load (TL Deflection=L/240)

Member	Yield strength F _y (ksi)	Live Load Deflection L/360						Live Load Deflection L/480					
		Single span spacing (in) o.c.			Two equal span spacing (in) o.c.			Single span spacing (in) o.c.			Two equal span spacing (in) o.c.		
		12	16	24	12	16	24	12	16	24	12	16	24
800S200-33	33	5' 9" e	4' 4" e	2' 10" e	4' 7" a	3' 5" a	2' 4" a	5' 9" e	4' 4" e	2' 10" e	4' 7" a	3' 5" a	2' 4" a
800S200-43	33	9' 1" e	7' 10" e	6' 4" e	8' 2" a	6' 8" a	4' 10" a	9' 1" e	7' 10" e	6' 4" e	8' 2" a	6' 8" a	4' 10" a
800S200-54	50	12' 1" e	10' 6" e	8' 7" e	12' 1" i	10' 6" a	7' 11" a	12' 0" e	10' 6" e	8' 7" e	12' 1" i	10' 6" a	7' 11" a
800S200-68	50	14' 2" e	12' 3" e	10' 0" e	14' 2" i	12' 3" i	10' 0" a	12' 11" e	10' 0" e	14' 2" i	12' 3" i	10' 0" a	12' 11" e
800S200-97	50	15' 9" e	14' 4" e	12' 6" e	17' 8" i	15' 5" i	12' 7" i	14' 4" e	13' 0" e	11' 4" e	16' 1" i	14' 7" i	12' 7" i
800S250-43	33	9' 4" e	8' 1" e	6' 4" e	8' 4" a	6' 9" a	4' 11" a	9' 4" e	8' 1" e	6' 4" e	8' 4" a	6' 9" a	4' 11" a
800S250-54	50	12' 5" e	10' 9" e	8' 9" e	12' 5" i	10' 8" a	8' 0" a	12' 5" e	10' 9" e	8' 9" e	12' 5" i	10' 8" a	8' 0" a
800S250-68	50	14' 6" e	12' 7" e	10' 3" e	14' 6" i	12' 7" i	10' 3" a	13' 5" e	12' 2" e	10' 3" e	14' 6" i	12' 7" i	10' 3" a
800S250-97	50	16' 6" e	15' 0" e	13' 0" e	18' 4" i	15' 11" i	13' 0" i	15' 0" e	13' 7" e	11' 11" e	16' 10" i	15' 3" i	13' 0" i
800S300-54	50	12' 7" e	10' 11" e	8' 11" e	12' 7" a	10' 9" a	8' 1" a	12' 7" e	10' 11" e	8' 11" e	12' 7" a	10' 9" a	8' 1" a
800S300-68	50	14' 9" e	12' 9" e	10' 5" e	14' 9" i	12' 9" i	10' 5" a	13' 10" e	12' 7" e	10' 5" e	14' 9" i	12' 9" i	10' 5" a
800S300-97	50	17' 1" e	15' 6" e	13' 3" e	18' 9" i	16' 3" i	13' 3" i	15' 6" e	14' 1" e	12' 4" e	17' 5" i	15' 10" i	13' 3" i
1000S162-43	33	9' 5" e	7' 7" e	5' 1" e	7' 5" a	5' 11" a	4' 1" a	9' 5" e	7' 7" e	5' 1" e	7' 5" a	5' 11" a	4' 1" a
1000S162-54	50	12' 7" e	10' 10" e	8' 10" e	12' 0" i	9' 9" a	7' 3" a	12' 7" e	10' 10" e	8' 10" e	12' 0" i	9' 9" a	7' 3" a
1000S162-68	50	14' 10" e	12' 10" e	10' 6" e	14' 10" i	12' 10" i	10' 6" a	14' 8" e	12' 10" e	10' 6" e	14' 10" i	12' 10" i	10' 6" a
1000S162-97	50	18' 1" e	16' 5" e	13' 5" e	18' 11" i	16' 5" i	13' 5" i	16' 5" e	14' 11" e	13' 1" e	18' 6" i	16' 5" i	13' 5" i
1000S200-43	33	10' 2" e	7' 7" e	5' 1" e	7' 8" a	6' 1" a	4' 1" a	10' 2" e	7' 7" e	5' 1" e	7' 8" a	6' 1" a	4' 1" a
1000S200-54	50	13' 6" e	11' 9" e	9' 7" e	12' 7" a	10' 2" a	7' 6" a	13' 6" e	11' 9" e	9' 7" e	12' 7" a	10' 2" a	7' 6" a
1000S200-68	50	15' 11" e	13' 9" e	11' 3" e	15' 11" i	13' 9" a	11' 3" a	15' 4" e	13' 9" e	11' 3" e	15' 11" i	13' 9" a	11' 3" a
1000S200-97	50	18' 11" e	17' 2" e	14' 4" e	20' 3" i	17' 6" i	14' 4" i	17' 2" e	15' 7" e	13' 8" e	19' 3" i	17' 6" i	14' 4" i
1000S250-54	50	13' 11" e	12' 0" e	9' 10" e	12' 9" a	10' 4" a	7' 7" a	13' 11" e	12' 0" e	9' 10" e	12' 9" a	10' 4" a	7' 7" a
1000S250-68	50	16' 4" e	14' 2" e	11' 7" e	16' 4" i	14' 2" a	11' 6" a	16' 0" e	14' 2" e	11' 7" e	16' 4" i	14' 2" a	11' 6" a
1000S250-97	50	19' 8" e	17' 11" e	14' 9" e	20' 10" i	18' 1" i	14' 9" i	17' 11" e	16' 3" e	14' 2" e	20' 1" i	18' 1" i	14' 9" i
1000S300-54	50	14' 1" e	12' 3" e	10' 0" e	12' 10" a	10' 5" a	7' 8" a	14' 1" e	12' 3" e	10' 0" e	12' 10" a	10' 5" a	7' 8" a
1000S300-68	50	16' 7" e	14' 5" e	11' 9" e	16' 7" i	14' 5" a	11' 7" a	16' 6" e	14' 5" e	11' 9" e	16' 7" i	14' 5" a	11' 7" a
1000S300-97	50	20' 4" e	18' 5" e	15' 0" e	21' 3" i	18' 5" i	15' 0" i	18' 5" e	16' 9" e	14' 8" e	20' 9" i	18' 5" i	15' 0" i
1200S162-54	50	13' 6" e	11' 8" e	8' 4" e	11' 6" a	9' 3" a	6' 8" a	13' 6" e	11' 8" e	8' 4" e	11' 6" a	9' 3" a	6' 8" a
1200S162-68	50	16' 1" e	13' 11" e	11' 4" e	16' 1" i	13' 11" a	10' 6" a	16' 1" e	13' 11" e	11' 4" e	16' 1" i	13' 11" a	10' 6" a
1200S162-97	50	20' 9" e	18' 0" e	14' 8" e	20' 9" i	18' 0" i	14' 8" i	19' 2" e	17' 5" e	14' 8" e	20' 9" i	18' 0" i	14' 8" i
1200S200-54	50	14' 8" e	12' 6" e	8' 4" e	12' 0" a	9' 7" a	6' 8" a	14' 8" e	12' 6" e	8' 4" e	12' 0" a	9' 7" a	6' 8" a
1200S200-68	50	17' 4" e	15' 0" e	12' 3" e	17' 4" i	14' 8" a	11' 0" a	17' 4" e	15' 0" e	12' 3" e	17' 4" i	14' 8" a	11' 0" a
1200S200-97	50	21' 11" e	19' 3" e	15' 9" e	22' 3" i	19' 3" i	15' 9" i	19' 11" e	18' 1" e	15' 9" e	22' 3" i	19' 3" i	15' 9" i

Notes:

- 1 Web punchouts are not considered for shear and web crippling.
- 2 Deflection checks are computed using unbalanced loads for the two equal span conditions.
- 3 "e" indicates that the web stiffeners are required at the end support only.
- 4 "i" indicates that the web stiffeners are required at the interior support only.
- 5 "a" indicates that the web stiffeners are required at all supports.
- 6 See additional floor joist notes on page 62.

Complies with AISI S100-16 (2020) w/S20-2 • IBC 2024

FLOOR JOIST SPAN LIMITATIONS

40psf Dead Load and 125psf Live Load (TL Deflection=L/240)

Member	Yield strength F _y (ksi)	Live Load Deflection L/360						Live Load Deflection L/480					
		Single span spacing (in) o.c.			Two equal span spacing (in) o.c.			Single span spacing (in) o.c.			Two equal span spacing (in) o.c.		
		12	16	24	12	16	24	12	16	24	12	16	24
1200S250-54	50	15' 2" e	12' 6" e	8' 4" e	12' 2" a	9' 9" a	6' 8" a	15' 2" e	12' 6" e	8' 4" e	12' 2" a	9' 9" a	6' 8" a
1200S250-68	50	17' 11" e	15' 6" e	12' 8" e	17' 11" a	14' 11" a	11' 2" a	17' 11" e	15' 6" e	12' 8" e	17' 11" a	14' 11" a	11' 2" a
1200S250-97	50	22' 9" e	19' 11" e	16' 3" e	23' 0" i	19' 11" i	16' 3" i	20' 8" e	18' 10" e	16' 3" e	23' 0" i	19' 11" i	16' 3" i
1200S300-54	50	15' 6" e	12' 6" e	8' 4" e	12' 3" a	9' 9" a	6' 8" a	15' 6" e	12' 6" e	8' 4" e	12' 3" a	9' 9" a	6' 8" a
1200S300-68	50	18' 3" e	15' 10" e	12' 11" e	18' 3" a	15' 1" a	11' 3" a	18' 3" e	15' 10" e	12' 11" e	18' 3" a	15' 1" a	11' 3" a
1200S300-97	50	23' 6" e	20' 4" e	16' 7" e	23' 6" i	20' 4" i	16' 7" i	21' 4" e	19' 5" e	16' 7" e	23' 6" i	20' 4" i	16' 7" i
1400S162-54	50	14' 3" e	10' 8" e	7' 2" e	10' 10" a	8' 7" a	5' 8" a	14' 3" e	10' 8" e	7' 2" e	10' 10" a	8' 7" a	5' 8" a
1400S162-68	50	17' 1" e	14' 9" e	12' 1" e	16' 8" i	13' 7" a	10' 1" a	17' 1" e	14' 9" e	12' 1" e	16' 8" i	13' 7" a	10' 1" a
1400S162-97	50	22' 3" e	19' 3" e	15' 9" e	22' 3" i	19' 3" i	15' 9" i	21' 8" e	19' 3" e	15' 9" e	22' 3" i	19' 3" i	15' 9" i
1400S200-54	50	14' 3" e	10' 8" e	7' 2" e	11' 3" a	8' 7" a	5' 8" a	14' 3" e	10' 8" e	7' 2" e	11' 3" a	8' 7" a	5' 8" a
1400S200-68	50	18' 6" e	16' 0" e	13' 1" e	17' 6" a	14' 2" a	10' 6" a	18' 6" e	16' 0" e	13' 1" e	17' 6" a	14' 2" a	10' 6" a
1400S200-97	50	24' 0" e	20' 9" e	17' 0" e	24' 0" i	20' 9" i	17' 0" a	22' 6" e	20' 6" e	17' 0" e	24' 0" i	20' 9" i	17' 0" a
1400S250-54	50	14' 3" e	10' 8" e	7' 2" e	11' 5" a	8' 7" a	5' 8" a	14' 3" e	10' 8" e	7' 2" e	11' 5" a	8' 7" a	5' 8" a
1400S250-68	50	19' 3" e	16' 8" e	13' 7" e	17' 11" a	14' 6" a	10' 8" a	19' 3" e	16' 8" e	13' 7" e	17' 11" a	14' 6" a	10' 8" a
1400S250-97	50	24' 11" e	21' 7" e	17' 7" e	24' 11" i	21' 7" i	17' 7" a	23' 4" e	21' 3" e	17' 7" e	24' 11" i	21' 7" i	17' 7" a
1400S300-54	50	14' 3" e	10' 8" e	7' 2" e	11' 5" a	8' 7" a	5' 8" a	14' 3" e	10' 8" e	7' 2" e	11' 5" a	8' 7" a	5' 8" a
1400S300-68	50	19' 8" e	17' 0" e	13' 11" e	18' 1" a	14' 8" a	10' 9" a	19' 8" e	17' 0" e	13' 11" e	18' 1" a	14' 8" a	10' 9" a
1400S300-97	50	25' 6" e	22' 1" e	18' 0" e	25' 6" i	22' 1" i	18' 0" a	24' 1" e	21' 11" e	18' 0" e	25' 6" i	22' 1" i	18' 0" a

Notes:

- 1 Web punchouts are not considered for shear and web crippling.
- 2 Deflection checks are computed using unbalanced loads for the two equal span conditions.
- 3 "e" indicates that the web stiffeners are required at the end support only.
- 4 "i" indicates that the web stiffeners are required at the interior support only.
- 5 "a" indicates that the web stiffeners are required at all supports.
- 6 See additional floor joist notes on page 62.

Complies with AISI S100-16 (2020) w/S2-20 • IBC 2024

The technical content of this literature is effective 06/01/24 and supersedes all previous information.



ALLOWABLE WEB CRIPPLING LOADS

Overview

Web crippling

The tables that follow identify the loads that can be handled by the joist web under four different conditions without web stiffeners. Web crippling can occur at member ends or at interior points along the member. A point load is considered to be an interior point load if it is greater than 1-1/2 times the web depth (h) from the end. Web crippling also can occur either with point loading on one flange of the member or on both flanges. The following illustrations identify the four possible conditions.

General Notes:

- 1 Web crippling capacities have been calculated in conformance with AISI S100-16 (2020) w/S2-20.
- 2 The tabulated values are for a single member. For multiple members, multiply the tabulated values by the number of members in the assembly.
- 3 All web crippling capacities listed are for studs/members with stiffened flanges (S-Sections).
- 4 Listed allowable capacities are based on members 'fastened to supports', except back-to-back members under two-flange loading (conditions 3 and 4), for which data for 'fastened to support' is unavailable in the AISI S100-16 (2020) w/S2-20.
- 5 Listed allowable capacities are for unpunched webs. Capacity reductions for end and interior one-flange loading (Conditions 1 and 2) near punchouts may be calculated using Section G6 of AISI S100 specification.

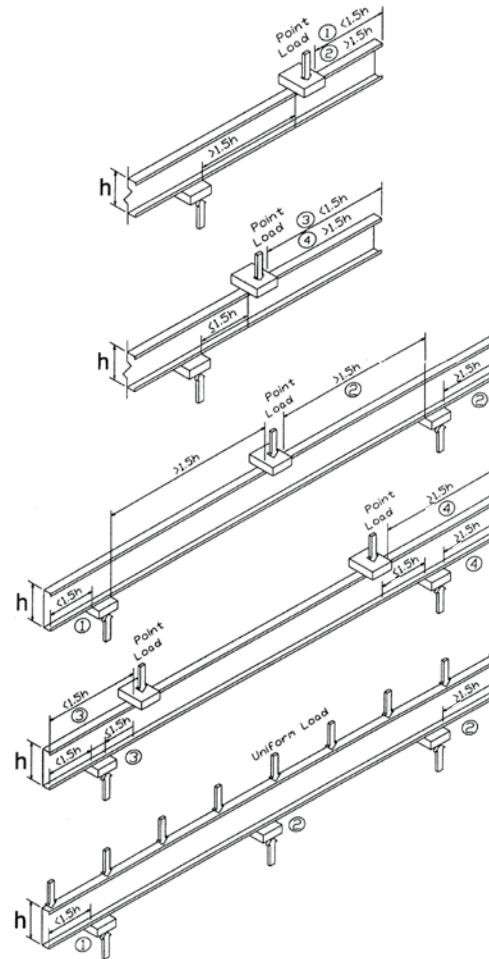

Load Conditions:

- 1 End one flange loading
- 2 Interior one flange loading
- 3 End two flange loading
- 4 Interior two flange loading

ALLOWABLE WEB CRIPPLING LOADS

For single members (lb)

Member	Yield strength (ksi)	CONDITION 1: End One Flange Loading, Bearing Length (in)				CONDITION 2: Interior One Flange Loading, Bearing Length (in)				CONDITION 3: End Two Flange Loading, Bearing Length (in)				CONDITION 4: Interior Two Flange Loading, Bearing Length (in)			
		1	3.5	4	6	1	3.5	4	6	1	3.5	4	6	1	3.5	4	6
250Sxxx - 33	33	173	271	285	336 ¹	330	453	472	535 ¹	150	201	209	235 ¹	411	519	535	591 ¹
250Sxxx - 43	33	287	443	466	547 ¹	580	780	810	913 ¹	267	351	364	407 ¹	720	892	918	1006 ¹
250Sxxx - 54	50	656	996	1046	1222 ¹	1350	1785	1850	2075 ¹	652	842	870	968 ¹	1730	2109	2165	2361 ¹
250Sxxx - 68	50	990	1480	1552	1805 ¹	2073	2694	2786	3106 ¹	1049	1333	1375	1521 ¹	2750	3302	3384	3669 ¹
250Sxxx - 97	50	1872	2726	2852	3293 ¹	4025	5095	5254	5806 ¹	2167	2683	2760	3026 ¹	5598	6575	6720	7225 ¹
350Sxxx - 33	33	166	260	274	323	324	445	463	526	131	175	182	205	384	484	499	551
350Sxxx - 43	33	278	428	451	528	571	768	798	900	240	315	326	365	680	842	866	949
350Sxxx - 54	50	637	967	1016	1186	1331	1761	1825	2046	594	768	794	883	1645	2005	2059	2245
350Sxxx - 68	50	965	1441	1512	1758	2047	2661	2752	3068	970	1232	1271	1406	2631	3159	3238	3510
350Sxxx - 97	50	1831	2666	2790	3221	3983	5042	5199	5745	2035	2520	2592	2842	5397	6339	6479	6966
362Sxxx - 33	33	165	259	273	322	323	444	462	525	129	173	179	202	381	480	495	547
362Sxxx - 43	33	277	427	449	526	570	767	796	898	236	311	322	360	675	836	860	943
362Sxxx - 54	50	634	963	1012	1182	1329	1758	1822	2043	588	760	785	874	1635	1994	2047	2232
362Sxxx - 68	50	962	1437	1507	1753	2044	2657	2748	3064	961	1221	1259	1393	2618	3143	3221	3492
362Sxxx - 97	50	1827	2659	2783	3212	3979	5036	5192	5738	2020	2501	2573	2821	5374	6313	6452	6936
400Sxxx - 33	33	163	256	269	317	322	442	460	522	122	164	170	192	372	469	483	534
400Sxxx - 43	33	274	422	444	520	567	763	792	893	227	299	309	346	662	819	843	924
400Sxxx - 54	50	628	954	1002	1170	1323	1750	1813	2034	569	735	760	846	1607	1960	2012	2194
400Sxxx - 68	50	953	1424	1494	1737	2036	2646	2737	3051	936	1188	1226	1356	2579	3097	3173	3441
400Sxxx - 97	50	1814	2640	2762	3189	3965	5018	5175	5718	1978	2448	2518	2761	5309	6236	6374	6853
550Sxxx - 33	33	155	243	256	302	315	432	450	511	100	134	139	157	339	428	441	487
550Sxxx - 43	33	262	405	426	499	556	749	778	877	195	256	265	297	614	760	782	858
550Sxxx - 54	50	606	920	966	1128	1302	1722	1784	2001	502	649	671	746	1508	1838	1887	2058
550Sxxx - 68	50	923	1380	1447	1683	2007	2608	2697	3007	844	1071	1105	1223	2441	2931	3003	3256
550Sxxx - 97	50	1766	2571	2691	3106	3917	4957	5112	5649	1826	2261	2326	2550	5079	5966	6097	6555
600Sxxx - 33	33	153	240	253	297	313	430	447	507	93	125	130	146	330	416	429	473
600Sxxx - 43	33	259	400	420	493	553	745	773	872	185	243	252	282	600	743	764	838
600Sxxx - 54	50	599	909	956	1116	1295	1713	1775	1991	482	623	644	716	1478	1802	1850	2017
600Sxxx - 68	50	914	1366	1433	1666	1998	2596	2685	2994	816	1036	1069	1183	2399	2881	2952	3201
600Sxxx - 97	50	1752	2551	2669	3081	3902	4939	5093	5628	1781	2205	2268	2487	5010	5885	6014	6466
800Sxxx - 33	33	144	226	238	281	305	419	436	495	69	92	96	108	294	371	383	422
800Sxxx - 43	33	247	381	401	470	542	730	757	854	150	197	204	228	548	678	698	765
800Sxxx - 54	50	575	872	917	1070	1272	1682	1743	1955	409	529	547	608	1370	1670	1714	1869
800Sxxx - 68	50	882	1318	1382	1607	1966	2555	2642	2946	716	910	939	1038	2250	2701	2768	3001
800Sxxx - 97	50	1702	2477	2592	2992	3850	4873	5025	5553	1618	2003	2060	2259	4761	5593	5716	6146
1000Sxxx - 43	33	236	364	383	449	532	716	743	839	119	156	162	181	502	622	640	701
1000Sxxx - 54	50	553	840	882	1031	1251	1655	1715	1923	346	447	462	514	1275	1554	1595	1740
1000Sxxx - 68	50	854	1275	1338	1556	1938	2518	2604	2904	629	799	824	912	2119	2544	2607	2827
1000Sxxx - 97	50	1657	2413	2525	2914	3805	4816	4966	5488	1476	1827	1879	2060	4545	5338	5456	5866
1200Sxxx - 54	50	534	811	852	995	1233	1630	1689	1895	288	372	385	428	1189	1450	1488	1623
1200Sxxx - 68	50	828	1237	1298	1509	1913	2486	2571	2866	551	699	721	798	2001	2402	2462	2669
1200Sxxx - 97	50	1618	2355	2464	2844	3764	4764	4912	5429	1348	1668	1716	1882	4350	5109	5222	5614
1400Sxxx - 54	50	516	784	824	962	1216	1608	1666	1869	235	304	314	350	1111	1354	1390	1516
1400Sxxx - 68	50	805	1202	1261	1466	1890	2456	2540	2832	479	608	627	694	1892	2272	2329	2525
1400Sxxx - 97	50	1581	2302	2408	2780	3727	4717	4864	5375	1230	1523	1567	1718	4171	4900	5008	5384

¹Bearing length to web height ratio, N/h, exceeds limit of 1.0.

²Bearing length to thickness ratio, N/t, exceeds limit of 210.

For web crippling general notes, see page 90.

Complies with AISI S100-16 (2020) w/S2-20 • IBC 2024

The technical content of this literature is effective 06/01/24 and supersedes all previous information.

ALLOWABLE WEB CRIPPLING LOADS

For built-up members (lbs)

Member	Yield strength (ksi)	CONDITION 1: End One Flange Loading, Bearing Length (in)				CONDITION 2: Interior One Flange Loading, Bearing Length (in)				CONDITION 3: End Two Flange Loading, Bearing Length (in)				CONDITION 4: Interior Two Flange Loading, Bearing Length (in)			
		1	3.5	4	6	1	3.5	4	6	1	3.5	4	6	1	3.5	4	6
250Sxxx - 33	33	389	592	622	727 ¹	546	723	749	840 ¹	256	323	333	368 ¹	544	686	708	781 ¹
250Sxxx - 43	33	637	952	999	1162 ¹	932	1209	1250	1393 ¹	455	563	580	636 ¹	982	1216	1251	1371 ¹
250Sxxx - 54	50	1435	2111	2212	2560 ¹	2159	2753	2842	3149 ¹	1106	1349	1385	1510 ¹	2393	2917	2995	3266 ¹
250Sxxx - 68	50	2145	3102	3244	3737 ¹	3311	4152	4277	4711 ¹	1778	2135	2188	2373 ¹	3846	4618	4733	5131 ¹
250Sxxx - 97	50	4006	5637	5878	6720 ¹	6423	7857	8070	8811 ¹	3671	4312	4407	4738 ¹	7940	9327	9532	10248 ¹
350Sxxx - 33	33	388	591	621	726 ¹	545	721	748	839 ¹	232	292	301	333 ¹	492	621	640	706 ¹
350Sxxx - 43	33	636	951	997	1160 ¹	931	1207	1248	1391 ¹	419	519	534	585 ¹	904	1119	1151	1263 ¹
350Sxxx - 54	50	1434	2109	2209	2557 ¹	2156	2750	2838	3144 ¹	1031	1257	1290	1407 ¹	2229	2718	2791	3043 ¹
350Sxxx - 68	50	2143	3098	3240	3733 ¹	3307	4147	4272	4706 ¹	1673	2009	2059	2232 ¹	3618	4345	4452	4827 ¹
350Sxxx - 97	50	4002	5631	5873	6713 ¹	6416	7850	8062	8802 ¹	3493	4103	4194	4508 ¹	7555	8874	9070	9751 ¹
362Sxxx - 33	33	388	591	621	726 ¹	545	721	747	839 ¹	229	289	298	329 ¹	486	613	632	698 ¹
362Sxxx - 43	33	636	950	997	1160 ¹	930	1207	1248	1391 ¹	415	514	528	579 ¹	895	1109	1140	1250 ¹
362Sxxx - 54	50	1433	2108	2208	2557 ¹	2156	2750	2838	3144 ¹	1022	1246	1280	1395 ¹	2211	2695	2767	3017 ¹
362Sxxx - 68	50	2143	3098	3239	3732 ¹	3307	4147	4271	4705 ¹	1661	1995	2044	2216 ¹	3592	4314	4421	4793 ¹
362Sxxx - 97	50	4001	5630	5872	6713 ¹	6416	7849	8061	8801 ¹	3473	4080	4170	4483 ¹	7511	8823	9018	9695 ¹
400Sxxx - 33	33	388	591	621	726 ¹	545	721	747	838 ¹	221	279	287	317 ¹	469	592	610	673 ¹
400Sxxx - 43	33	635	950	997	1159 ¹	930	1206	1247	1390 ¹	403	499	513	563 ¹	870	1077	1108	1215 ¹
400Sxxx - 54	50	1433	2107	2207	2556 ¹	2155	2748	2836	3143 ¹	998	1216	1249	1361 ¹	2157	2630	2700	2944 ¹
400Sxxx - 68	50	2142	3097	3238	3731 ¹	3305	4145	4270	4703 ¹	1627	1953	2002	2170 ¹	3518	4224	4329	4694 ¹
400Sxxx - 97	50	4000	5628	5870	6711 ¹	6414	7846	8059	8798 ¹	3415	4012	4100	4408 ¹	7386	8676	8868	9534 ¹
550Sxxx - 33	33	387	590	620	724 ¹	544	720	746	836 ¹	192	242	250	276 ¹	407	514	530	585 ¹
550Sxxx - 43	33	634	948	995	1157 ¹	928	1204	1245	1388 ¹	361	447	459	504 ¹	778	964	991	1087 ¹
550Sxxx - 54	50	1431	2104	2204	2552 ¹	2152	2744	2832	3138 ¹	909	1108	1138	1241 ¹	1966	2397	2461	2683 ¹
550Sxxx - 68	50	2139	3092	3234	3726 ¹	3301	4139	4264	4697 ¹	1504	1806	1851	2007 ¹	3253	3906	4003	4340 ¹
550Sxxx - 97	50	3995	5622	5863	6703 ¹	6406	7837	8049	8788 ¹	3211	3771	3855	4144 ¹	6944	8157	8337	8963 ¹
600Sxxx - 33	33	387	589	619	724 ¹	543	719	745	836 ¹	183	231	238	263 ¹	389	491	506	559 ¹
600Sxxx - 43	33	634	948	995	1157 ¹	928	1204	1245	1387 ¹	348	431	443	486 ¹	751	930	956	1048 ¹
600Sxxx - 54	50	1430	2103	2203	2551 ¹	2151	2743	2831	3136 ¹	883	1076	1105	1205 ¹	1909	2327	2389	2605 ¹
600Sxxx - 68	50	2138	3091	3233	3724 ¹	3299	4138	4262	4695 ¹	1467	1762	1806	1958 ¹	3173	3811	3905	4234 ¹
600Sxxx - 97	50	3994	5620	5861	6701 ¹	6404	7834	8046	8785 ¹	3150	3700	3781	4065 ¹	6812	8001	8178	8792 ¹
800Sxxx - 33	33	386	588	618	722	542	718	744	834	152	192	197	218	322	407	419	463
800Sxxx - 43	33	633	946	993	1154	926	1202	1242	1384	302	374	384	421	651	806	829	909
800Sxxx - 54	50	1428	2100	2200	2546	2147	2738	2826	3131	787	959	985	1074	1701	2074	2129	2322
800Sxxx - 68	50	2135	3087	3228	3719	3295	4132	4256	4688	1335	1602	1642	1780	2886	3466	3552	3851
800Sxxx - 97	50	3989	5613	5854	6692	6396	7825	8036	8774	2929	3441	3517	3781	6335	7442	7606	8177
1000Sxxx - 43	33	632	945	991	1153	925	1200	1240	1382	261	324	333	365	564	698	718	787
1000Sxxx - 54	50	1426	2097	2196	2543	2144	2735	2822	3127	702	856	879	959	1519	1852	1901	2073
1000Sxxx - 68	50	2132	3083	3224	3714	3290	4126	4250	4682	1218	1463	1499	1625	2635	3164	3242	3515
1000Sxxx - 97	50	3985	5607	5848	6685	6389	7816	8028	8764	2737	3215	3286	3533	5919	6953	7107	7640
1200Sxxx - 54	50	1424	2094	2193	2539	2141	2731	2818	3123	627	764	784	855	1355	1652	1696	1849
1200Sxxx - 68	50	2130	3079	3220	3710	3287	4122	4245	4676	1114	1337	1370	1486	2408	2892	2964	3213
1200Sxxx - 97	50	3981	5601	5842	6678	6383	7808	8020	8756	2564	3012	3078	3309	5545	6514	6658	7158
1400Sxxx - 54	50	1422	2092	2191	2536	2139	2728	2815	3119	557	679	697	760	1204	1468	1507	1644
1400Sxxx - 68	50	2127	3076	3216	3706	3283	4117	4241	4671	1018	1222	1252	1358	2201	2642	2708	2936
1400Sxxx - 97	50	3977	5596	5837	6672	6377	7801	8013	8748	2406	2826	2888	3105	5203	6111	6246	6715

¹Bearing length to web height ratio, N/h, exceeds limit of 1.0.

²Bearing length to thickness ratio, N/t, exceeds limit of 210.

For web crippling general notes, see page 90.

Complies with AISI S100-16 (2020) w/S2-20 • IBC 2024

The technical content of this literature is effective 06/01/24 and supersedes all previous information.



REFERENCE



Fastening Options

Connections can be made using a variety of fastening options. It is critical to specify the proper fastener to ensure the proper performance of the connections in cold-formed steel construction. The most common and widely used connection methods are screw connections and weld connections. Each type of connection method has various advantages and disadvantages. Therefore, we provide data for both types so you can choose your preferred connection method.



Self-Drilling Screws—externally threaded fasteners with the ability to drill their own hole and form, or “tap,” their own internal threads without deforming their thread and without breaking during installation. These screws are high-strength, one-piece fasteners and are used if the connection of multiple thicknesses of 33mil steel or thicker. One of the more

common self-drilling screws is a #10-16 x 5/8 HWH SD, which indicates a #10 diameter shaft, 16 threads per inch, 5/8 length, hex washer head self-drilling screw.

Fillet Welds—used to make lap joints, corner joints and T-joint connections. As the illustration suggests, the fillet weld is roughly triangular in cross-section, although its shape is not always a right triangle or an isosceles triangle. Weld metal is deposited in a corner formed by the fit-up of the two members and penetrates and fuses with the base metal to form the joint.

Flare Welds—used to join rounded or curved pieces.

- A Flare Bevel groove weld is commonly used to join a rounded or curved piece to a flat piece.
- A Flare V groove weld is commonly used to join two rounded or curved parts.

ALLOWABLE SCREW DESIGN VALUES (LBS/SCREW)

Mils (Gauge)	Design thickness (in)	F _y (ksi)	F _u (ksi)	#8 Screw 0.164" Dia, 0.272" Head Pss = 1000 lbs; Pts = 1545 lbs			#10 Screw 0.190" Dia, 0.340" Head Pss = 1400 lbs; Pts = 1936 lbs			#12 Screw 0.216" Dia, 0.340" Head Pss = 2000 lbs; Pts = 2778 lbs			1/4" Screw 0.250" Dia, 0.409" Head Pss = 2600 lbs; Pts = 4060 lbs		
				Tension			Tension			Tension			Tension		
				Shear	Pull-Over	Pull-Out	Shear	Pull-Over	Pull-Out	Shear	Pull-Over	Pull-Out	Shear	Pull-Over	Pull-Out
33 (20g)	0.0346	33	45	164	212	72	177	265	84	188	265	95	203	318	110
43 (18g)	0.0451	33	45	244	276	94	263	345	109	280	345	124	302	415	144
54 (16g)	0.0566	33	45	333	346	118	370	433	137	394	433	156	424	521	180
		50	65	333	500	171	467	625	198	569	625	225	613	752	261
68 (14g)	0.0713	33	45	333	436	149	467	545	173	557	545	196	600	656	227
		50	65	333	515	215	467	645	249	667	788	284	866	948	328
97 (12g)	0.1017	33	45	333	515	213	467	645	246	667	778	280	867	936	324
		50	65	333	515	307	467	645	356	667	926	405	867	1352	468
118 (10g)	0.1242	33	45	333	515	260	467	645	301	667	926	342	867	1143	396
		50	65	333	515	375	467	645	435	667	926	494	867	1353	572

Screw Value Notes:

- 1 Capacities are based on Section J4 of the AISI S100-16 (2020) w/S2-20 Calculations.
- 2 When connecting materials of different steel thickness or tensile strengths, use the lowest values. Tabulated capacities assume two sheets of equal thickness are connected.
- 3 Calculated capacities are based on Allowable Strength Design (ASD) and include appropriate safety factors.
- 4 When multiple fasteners are used, screws are assumed to have a center-to-center spacing of at least 3 times the nominal diameter.
- 5 Screws are assumed to have a center-of-screw to edge-of-steel dimension of at least 1.5 times the nominal diameter of the screw.
- 6 Pullout capacity is based on the lesser of pull-out capacity in sheet closest to screw tip or tension strength of screw.
- 7 Pullover capacity is based on the lesser of pullover capacity for sheet closest to screw header, or tension strength of screw.
- 8 Listed capacities are for pure shear or tension loads only. For combined shear and pullover, see AISI S100 Section J4.5.
- 9 Shear strength for #8, #10, #12, and 1/4" screws shall be greater than or equal to 1000 lbs, 1400 lbs, 2000 lbs, and 2600 lbs respectively.
- 10 Tension strength for #8, #10, #12, and 1/4" screws shall be greater than or equal to 1545 lbs, 1936 lbs, 2778 lbs, and 4060 lbs respectively.

ALLOWABLE WELD VALUES (LBS/IN)

Mils (Gauge)	Design thickness (in)	F _y (ksi)	F _u (ksi)	Weld (1 inch)	
				Fillet	Flare Groove
43 (18)	0.0451	33	45	619	544
		33	45	822	682
54 (16)	0.0566	50	65	1188	985
		33	45	1082	859
68 (14)	0.0713	50	65	1563	1241
		33	45	1269	1226
97 (12)	0.1017	50	65	1269	1402
		33	45	1550	1497
118 (10)	0.1242	50	65	1550	1712

Weld Value Notes:

- 1 Capacities are based on Sections J2.5, and J2.6 of the AISI S100-16 (2020) w/S2-20 Calculations.
- 2 When connecting materials of different steel thickness or tensile strengths, use the lowest values. Tabulated capacities assume two sheets of equal thickness are connected.
- 3 Calculated capacities are based on Allowable Strength Design (ASD) and include appropriate safety factors.
- 4 Weld strengths are given in lbs/in and are based on E60XX electrodes.
- 5 For flare groove welds when t > 0.1", tw = (5/16)*R when weld filled flush to surface.

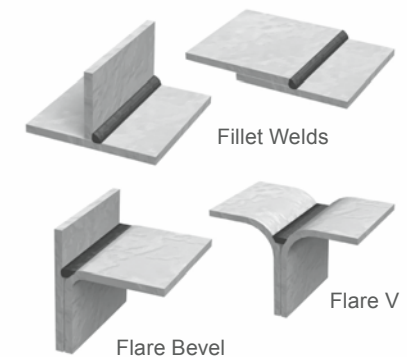

Complies with AISI S100-16 (2020) w/S2-20 • IBC 2024

The technical content of this literature is effective 06/01/24 and supersedes all previous information.

Rigid Connections

Stud to Track Connection

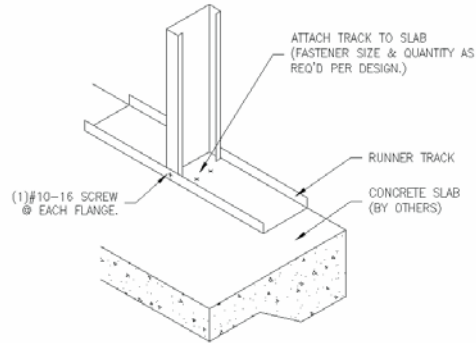

Rigid Bypass

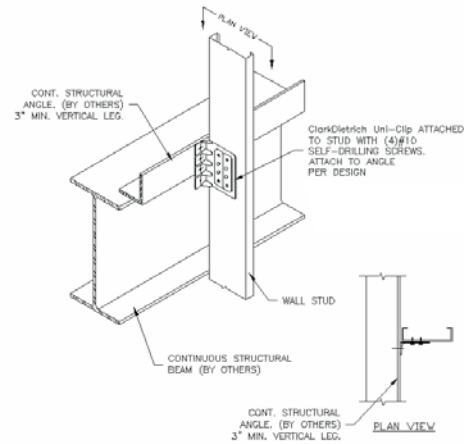

Hold Down Detail

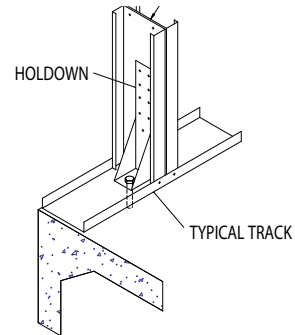

Bypass Deflection Connections

Minimal to Medium Standoff

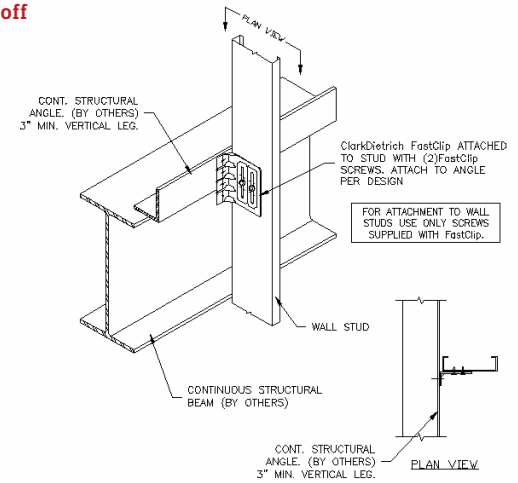

Large Standoff

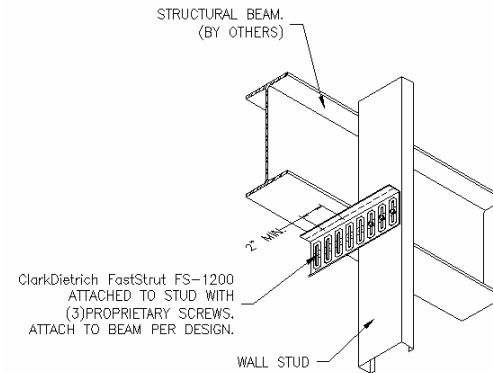

Details shown in this brochure are for example only. The engineer of record on the project is responsible for the design of the connection to the structure. Additional connection details can be found at clarkdietrich.com.

Complies with AISI S100-16 (2020) w/S2-20 • IBC 2024

The technical content of this literature is effective 06/01/24 and supersedes all previous information.

Typical Construction Details

For a downloadable .pdf or .dwg version of all details, go to <http://cad.clarkdietrich.com>.

Bridging Details

Spazzer® 5400 Bridging

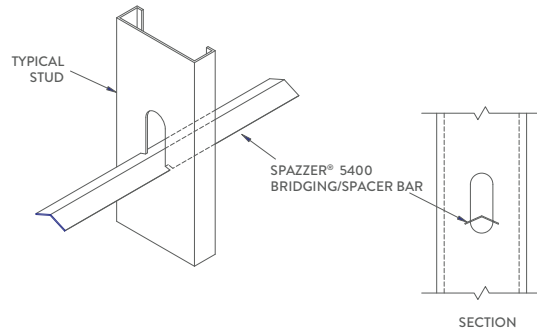

U-Channel Bridging Connection

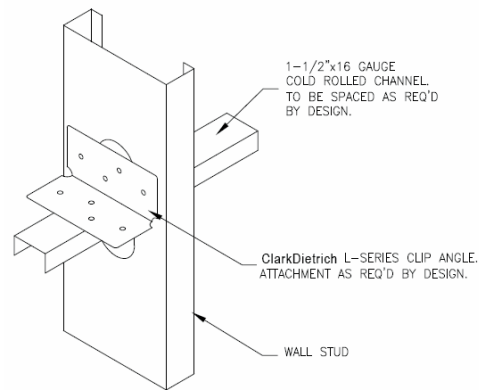

THIS DETAIL IS NOT SUITABLE FOR WALL STUDS DEEPER THAN 6"

Block and Strap Bridging

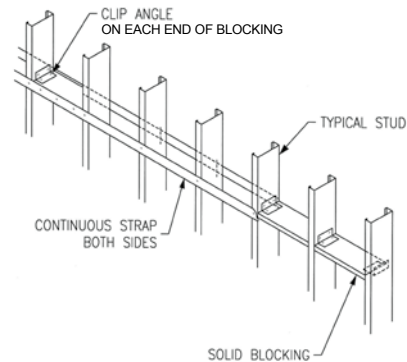

Header Details

Load-Bearing Boxed Header

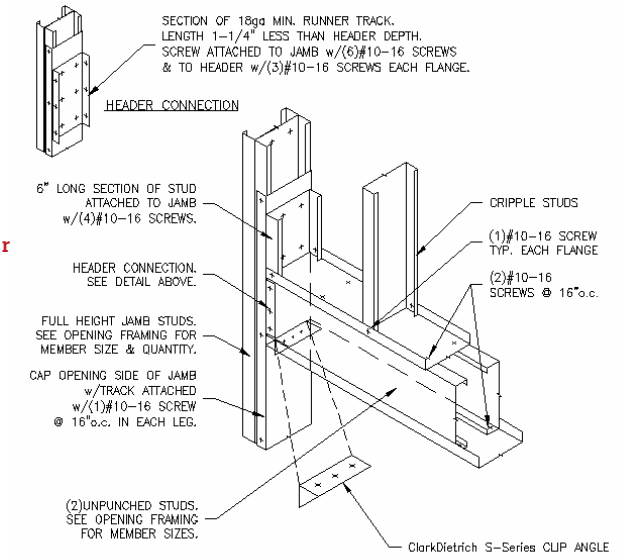

Load-Bearing Back-to-Back Header

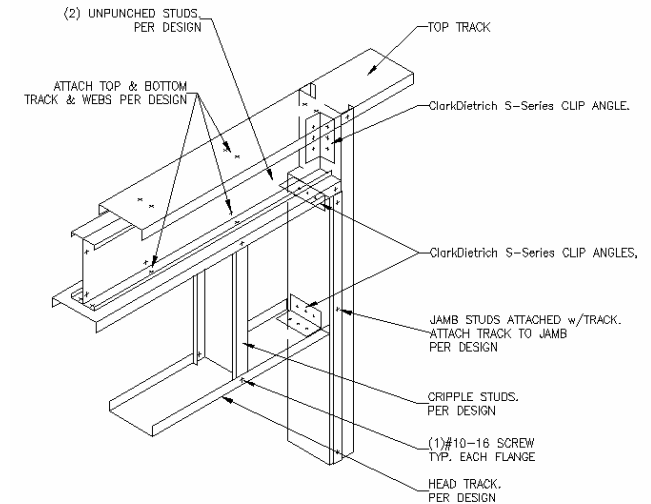

Details shown in this brochure are for example only. The engineer of record on the project is responsible for the design of the connection to the structure. Additional connection details can be found at clarkdietrich.com.

Complies with AISI S100-16 (2020) w/S2-20 • IBC 2024

Header Details

Curtain Wall HDS® Header & Jamb

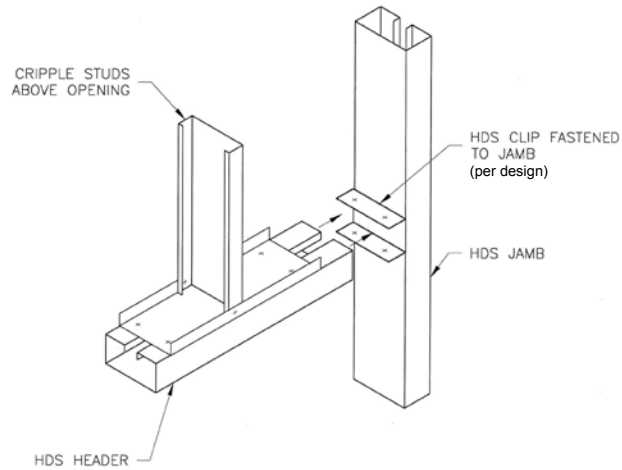

Load-Bearing HDS Header & Jamb

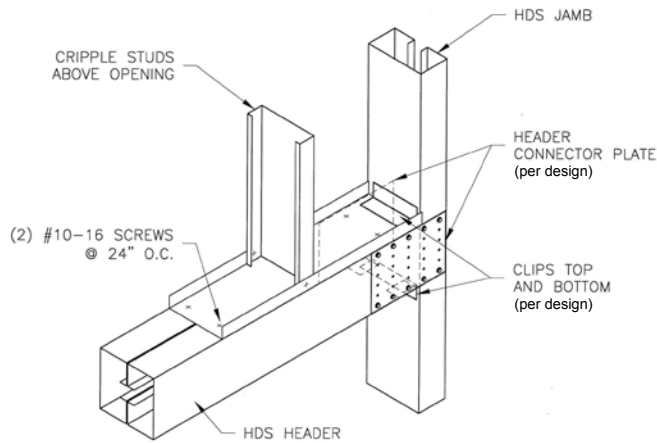

Curtain Wall RedHeader PRO™ Header & Jamb

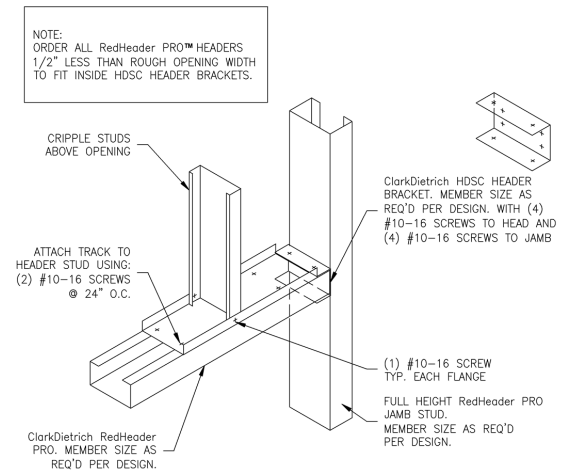

Complies with AISI S100-16 (2020) w/S2-20 • IBC 2024

The technical content of this literature is effective 06/01/24 and supersedes all previous information.

Typical Construction Details

For a downloadable .pdf or .dwg version of all details, go to <http://cad.clarkdietrich.com>.

Head-of-Wall Deflection Typical Details

MaxTRAK® Slotted Track

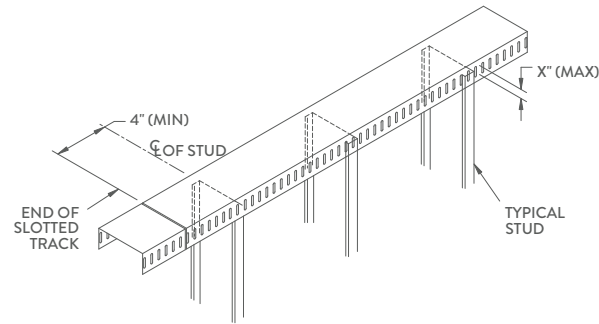

Long Leg Track with Spazzer® 5400

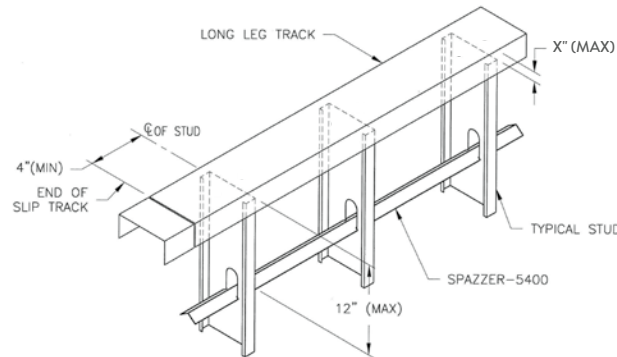

Long Leg Track with U-Channel

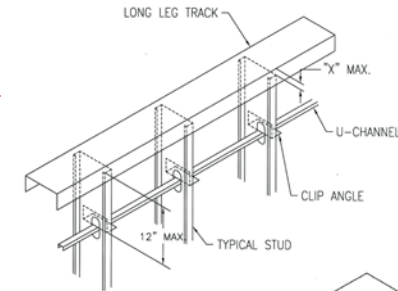

Double Track™

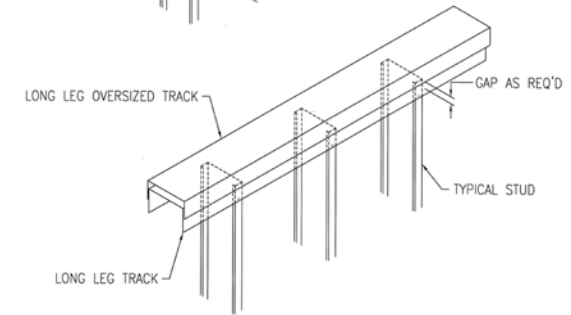

Long Leg Track with FastTop™ Clip

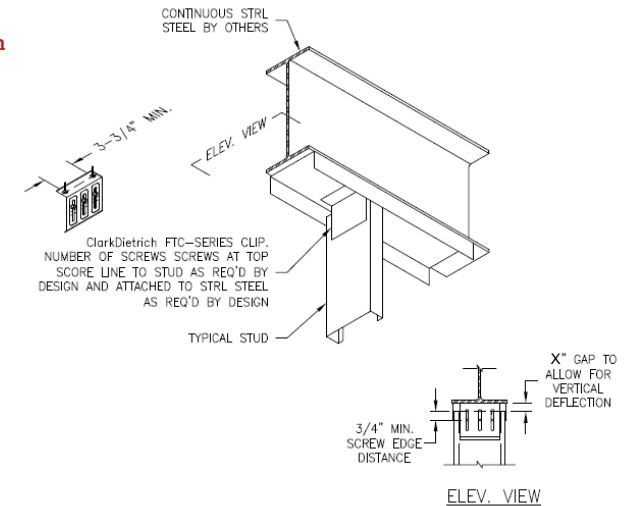

Details shown in this brochure are for example only. The engineer of record on the project is responsible for the design of the connection to the structure. Additional connection details can be found at clarkdietrich.com.

Complies with AISI S100-16 (2020) w/S2-20 • IBC 2024

The technical content of this literature is effective 06/01/24 and supersedes all previous information.

ClarkDietrich Material Certification—Code Approvals and Performance Standards

Structural Framing Standards

AISI S100-16 (2020) w/S2-20 - North American Specification for the Design of Cold-Formed Steel Structural Members

AISI S240-20 - North American Standard for Cold-Formed Steel Structural Framing

(Compliant to ASTM C955, but IBC replaced with AISI S200 in IBC 2015, AISI S240 in IBC 2018)

Section A3 Material - Chemical & mechanical requirements (Referencing ASTM A1003/A1003M)

Section A4 Corrosion Protection (Referencing ASTM A653/A653M)

Section A5 Products - Thickness, shapes, tolerances, identification

Section C Installation (Referencing ASTM C1007)

AISI S202-20 - Code of Standard Practice for Cold-Formed Steel Structural Framing

Section F3 Delivery, handling and storage of materials

ClarkDietrich Structural Framing comply with:

Intertek CCR-0206 - Structural Studs and Track

ICC-ES ESR-1166P

SFIA (Steel Framing Industry Association) Code Compliance Certification Program

LEED® Services

BUILD GREEN with ClarkDietrich

ClarkDietrich is an active member of the U.S. Green Building Council and is committed to supplying quality products that are environmentally responsible. We are continually working to develop greener building products and sustainable business practices. ClarkDietrich steel framing helps contribute points toward LEED® certification. For more details contact Technical Services at 888-437-3244 or visit www.clarkdietrich.com/LEED.

SustainabilityPro

Quickly access the product-specific information and certifications needed to calculate contributions to LEED® and other green building certification and rating systems—all in one platform.

Find out more at www.clarkdietrich.com/LEED

ClarkDietrich structural framing comply with the SFIA Code Compliance Program. ClarkDietrich is a member of SFIA.

Check the updated list of Certified Production Facilities at Intertek's website at www.intertek.com.



USGBC and related logo is a trademark owned by the U.S. Green Building Council and is used by permission.

MANUFACTURING AND SALES LOCATIONS

CALIFORNIA Riverside
P 951.360.3500

CALIFORNIA Sacramento
P 951.360.3500

CONNECTICUT Bristol
P 866.921.0023

FLORIDA Dade City
P 352.518.4400

FLORIDA Miami
P 305.477.6464

GEORGIA McDonough
P 678.304.5500

ILLINOIS Rochelle
P 800.659.0745

MARYLAND Baltimore
P 410.477.4000

MISSOURI O'Fallon
P 636.300.1411

OHIO Warren-East
P 330.372.5564

OHIO Vienna
P 330.372.4014

TEXAS Dallas
P 214.350.1716

TEXAS Pasadena
P 281.383.1617

ENGINEERING SERVICES

A full spectrum of solutions.

Toll-Free Phone: 877.832.3206

Toll-Free Fax: 877.832.3208

Technical Services: 888.437.3244

Email: engineering@clarkdietrich.com

CENTRAL Crown Point, IN

NORTHEAST Bristol, CT

SOUTHEAST McDonough, GA

WEST Carlsbad, CA

ClarkDietrich has prepared this literature with the utmost diligence and care for accuracy and conformance to standards.

ClarkDietrich reserves the right to modify or change any information contained in this literature without notification.

ClarkDietrich intends this information to be accurate, informative, and helpful as a selection guide for choosing ClarkDietrich Building System products. However, this information is only to be used for guidance and is not intended to replace the design, drawings, specifications, and decisions of a professional architect or engineer.

ClarkDietrich or its affiliates shall not be responsible for incidental or consequential damages, directly or indirectly sustained, nor for loss caused by application of our products for other than their intended uses. Our liability is limited to replacement of defective products. Claims shall be deemed waived unless they are made to us in writing within thirty (30) days of the date a problem was or reasonably should have been discovered.

For the most up to date version of all ClarkDietrich literature, scan the QR code below.



Complies with AISI S100-16 (2020) w/S2-20 • IBC 2024

The technical content of this literature is effective 06/01/24 and supersedes all previous information.

Turn to ClarkDietrich for a complete lineup of steel construction products and services nationwide:

Interior Framing · Exterior Framing · Interior Finishing · Exterior Finishing · Clips/Connectors · Engineering



9050 Centre Pointe Dr. Suite 400
West Chester, OH 45069

P 513.870.1100
F 513.870.1300

clarkdietrich.com
Clarkwestern Dietrich Building Systems LLC

PanelTRAK

ClarkDietrich PanelTRAK is a structural steel track that allows steel studs to bear directly on the track web rather than the radii of the track corners. Because of its slightly oversized web base, it creates an easier installation in load-bearing applications. PanelTRAK can be used in axial load-bearing walls, curtain walls, tall interior partitions, floor joists and roof truss assemblies.

ClarkDietrich PanelTRAK is a U-shaped framing component used as top and bottom runners to secure wall studs. PanelTRAK is also used as head and sill plates of wall openings and solid blocking. PanelTRAK is normally ordered in corresponding size and gauge to the wall studs.

MATERIAL SPECIFICATIONS

Gauge: 33 mils (20ga), 43 mils (18ga),
54 mils (16ga), and 68 mils (14ga)

Coating: CP60

Yield Strength: 33ksi for 20ga and 18ga
50ksi for 16ga and 14ga

PRODUCT DIMENSIONS

WEB SIZE: 3-5/8", 4", 6" and 8"

LEG HEIGHTS: 1-1/2" and 2"

LENGTH: 10' lengths. (Custom lengths available)

INSTALLATION

PanelTRAK incorporates a web slightly wider than the accompanying stud width, and has the legs bent inward, just under 90 degrees. This locates the bend radii of the track outside the plane of the bearing stud with the leg ends matching the width of the bearing stud. Thus, allowing the load-bearing stud to directly seat/bear on the track web. PanelTRAK can be used in axial load-bearing walls, curtain walls, tall interior partitions, floor joists and roof truss assemblies.

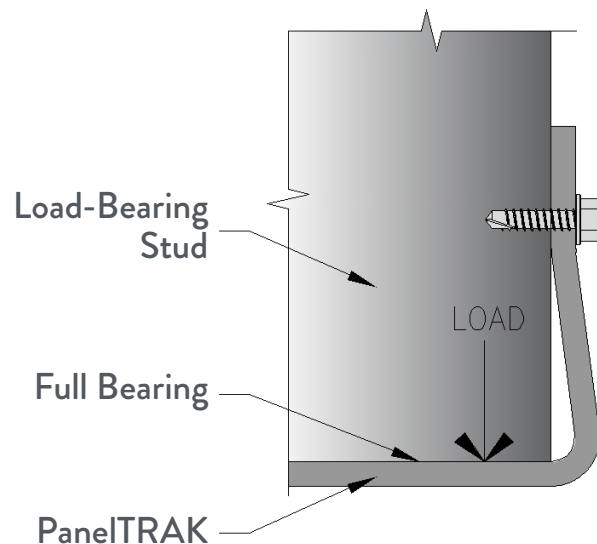
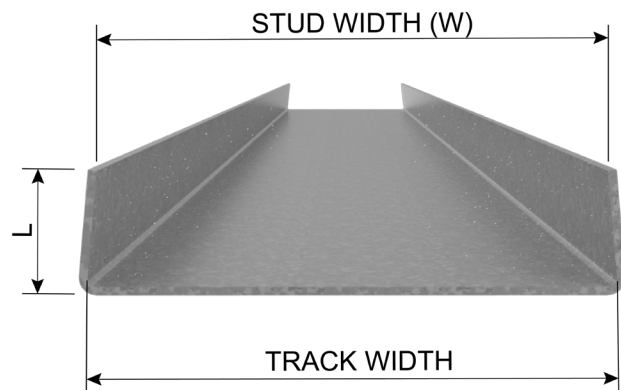
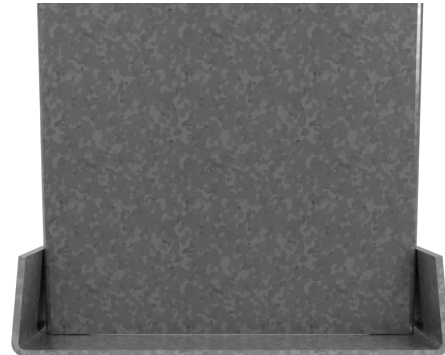

PanelTRAK

Product code	Web depth		Flare width	Design thickness	Yield Stress	Area	Weight	Gross Section Properties						Effective Section Properties								
	W ₁	W ₂	L ₁	t				Strong Axis			Weak Axis			Strong Axis			Weak Axis (Web in Compression)			Weak Axis (Web in Tension)		
	in	in	in	Mils (ga)	F _y	A _z		I _x	S _x	R _x	I _y	S _y	R _y	I _{xe}	S _{xe}	M _{ax}	I _{yec}	S _{yec}	M _{ayc}	I _{yet}	S _{yet}	M _{ayt}
	ksi	in ²	lb/ft	in ⁴	in ³	in		in ⁴	in ³	in	in ⁴	in ³	in	in ⁴	in ³	lb-in	in ⁴	in ³	lb-in	in ⁴	in ³	lb-in
3-5/8" PanelTRAK	3-5/8	3-3/4	1-1/2	33 (20)	33	0.231	0.79	0.493	0.258	1.461	0.050	0.144	0.465	0.417	0.182	3596	0.049	0.042	824	0.020	0.016	325
				43 (18)	33	0.301	1.02	0.645	0.336	1.464	0.065	0.185	0.463	0.580	0.257	5083	0.065	0.056	1097	0.043	0.031	606
				54 (16)	50	0.377	1.28	0.811	0.420	1.467	0.080	0.226	0.461	0.736	0.327	9787	0.080	0.069	2072	0.055	0.040	1184
			2	33 (20)	33	0.266	0.90	0.599	0.314	1.502	0.110	0.208	0.643	0.463	0.191	3770	0.105	0.071	1396	0.028	0.020	398
				43 (18)	33	0.346	1.18	0.785	0.409	1.505	0.142	0.267	0.641	0.649	0.271	5359	0.142	0.095	1874	0.062	0.038	759
				54 (16)	50	0.434	1.48	0.987	0.511	1.509	0.177	0.330	0.639	0.825	0.345	10333	0.177	0.119	3550	0.081	0.050	1493
4" PanelTRAK	4	4-1/8	1-1/2	33 (20)	33	0.244	0.83	0.617	0.294	1.590	0.051	0.156	0.459	0.524	0.210	4153	0.049	0.042	827	0.020	0.016	320
				43 (18)	33	0.318	1.08	0.807	0.383	1.593	0.066	0.199	0.457	0.726	0.296	5846	0.066	0.056	1103	0.042	0.030	597
				54 (16)	50	0.398	1.35	1.013	0.478	1.595	0.082	0.244	0.454	0.921	0.376	11246	0.082	0.070	2083	0.055	0.039	1167
			2	33 (20)	33	0.279	0.95	0.747	0.356	1.637	0.113	0.224	0.638	0.581	0.220	4356	0.106	0.071	1401	0.028	0.020	389
				43 (18)	33	0.363	1.24	0.977	0.464	1.640	0.147	0.288	0.635	0.811	0.312	6164	0.146	0.095	1884	0.061	0.038	745
				54 (16)	50	0.455	1.55	1.229	0.580	1.644	0.182	0.356	0.633	1.030	0.397	11875	0.182	0.119	3570	0.080	0.049	1467
6" PanelTRAK	6	6-1/8	1-1/2	33 (20)	33	0.313	1.07	1.588	0.513	2.252	0.057	0.217	0.425	1.345	0.305	6034	0.051	0.042	837	0.019	0.015	297
				43 (18)	33	0.408	1.39	2.074	0.667	2.254	0.073	0.277	0.423	1.906	0.477	9425	0.070	0.057	1122	0.041	0.028	561
				54 (16)	50	0.511	1.74	2.601	0.834	2.255	0.091	0.338	0.421	2.412	0.612	18337	0.087	0.071	2119	0.053	0.037	1100
			2	33 (20)	33	0.348	1.18	1.887	0.609	2.329	0.127	0.309	0.603	1.546	0.336	6643	0.111	0.072	1419	0.025	0.018	356
				43 (18)	33	0.453	1.54	2.466	0.793	2.332	0.164	0.397	0.601	2.085	0.567	11208	0.154	0.097	1917	0.057	0.035	688
				54 (16)	50	0.568	1.93	3.095	0.992	2.334	0.204	0.489	0.599	2.640	0.719	21524	0.192	0.121	3632	0.075	0.045	1360
8" PanelTRAK	8	8-1/8	1-1/2	33 (20)*	33	0.382	1.30	3.186	0.778	2.886	0.060	0.277	0.396	2.589	0.417	8240	0.052	0.043	843	0.018	0.014	284
				43 (18)	33	0.498	1.70	4.158	1.012	2.888	0.077	0.351	0.394	3.719	0.660	13036	0.072	0.057	1131	0.040	0.027	538
				54 (16)	50	0.624	2.12	5.212	1.265	2.889	0.096	0.427	0.392	4.714	0.849	25411	0.090	0.071	2136	0.052	0.035	1058
			2	33 (20)*	33	0.417	1.42	3.724	0.909	2.988	0.135	0.394	0.570	2.799	0.426	8421	0.112	0.072	1427	0.024	0.017	336
				43 (18)	33	0.544	1.85	4.862	1.184	2.990	0.175	0.504	0.568	4.060	0.679	13423	0.158	0.098	1933	0.055	0.033	652
				54 (16)	50	0.681	2.32	6.098	1.480	2.992	0.218	0.619	0.565	5.154	0.875	26205	0.197	0.122	3663	0.072	0.043	1291
68 (14)	50	0.856	2.91	7.673	1.856	2.993	0.271	0.759	0.563	7.010	1.311	39242	0.259	0.158	4724	0.143	0.076	2280				

Notes:

- 1 Section Properties Are Based on Using AISI S100-16 w/S2-20.
- 2 Axial load capacities are based on fully-braced condition (structural elements that are installed to provide full restraint or support, i.e. KL=0).
- 3 *Web depth to thickness ratio greater than 200, bearing stiffeners required in accordance with Section F5.1 of AISI S100.

I_x = Gross Moment Of Inertia about x-axis.

S_x = Gross Section Modulus about x-axis.

R_x = Gross Radius of Gyration about x-axis.

I_y = Gross Moment Of Inertia about y-axis.

S_y = Gross Section Modulus about y-axis.

R_y = Gross Radius of Gyration about y-axis.

J = St. Venant Torsion Constant.

C_w = Warping Torsion Constant.

X_o = Distance from shear center to the centroid along the principal x-axis.

m = Distance between shear center and web centerline

R_o = Polar Radius of Gyration about the centroidal principal axis.

β = 1-(X_o/r_o)²

S_{xe} = Effective Section Modulus about x-axis.

I_{xe} = Effective Moment Of Inertia about x-axis for deflection calculations.

M_{ax} = Allowable local buckling moment capacity about x-axis.

S_{yec} = Effective Section Modulus about y-axis while web in compression.

I_{yec} = Effective Moment Of Inertia about y-axis for deflection calculations while web in compression.

M_{ayc} = Allowable local buckling moment capacity about y-axis while web in compression.

S_{yet} = Effective Section Modulus about y-axis while web in tension.

I_{yet} = Effective Moment Of Inertia about y-axis for deflection calculations while web in tension.

M_{ayt} = Allowable local buckling moment capacity about y-axis while web in tension.

V_{ag} = Allowable Shear about x-axis.

P_a = Allowable Axial Load.

Product code	Web depth		Flare width L ₁	Design thickness t	Area A _z	Weight	Torsional Section Properties						Effective Area A _e	Axial Load P _a	Shear V _{sg}
	W ₁	W ₂					Jx1000	C _w	X _o	m	R _o	β			
	in	in	in ⁴	in ²	in	in							in	in ²	lb
3-5/8" PanelTRAK	3-5/8	3-3/4	1-1/2	33 (20)	0.231	0.79	0.092	0.128	-0.852	0.522	1.754	0.764	0.111	2029	1024
				43 (18)	0.301	1.02	0.204	0.167	-0.846	0.519	1.753	0.767	0.177	3249	1740
				54 (16)	0.377	1.28	0.402	0.208	-0.841	0.515	1.752	0.770	0.229	6359	3372
			68 (14)	0.473	1.61	0.801	0.261	-0.834	0.511	1.752	0.773	0.346	9624	4728	
			33 (20)	0.266	0.9	0.106	0.280	-1.268	0.755	2.068	0.624	0.112	2051	1024	
			43 (18)	0.346	1.18	0.235	0.364	-1.262	0.751	2.066	0.627	0.180	3299	1740	
	2	54 (16)	0.434	1.48	0.463	0.456	-1.256	0.748	2.065	0.630	0.233	6461	3372		
		68 (14)	0.544	1.85	0.922	0.573	-1.249	0.743	2.063	0.633	0.354	9839	4728		
		33 (20)	0.244	0.83	0.097	0.160	-0.819	0.507	1.846	0.803	0.111	2043	928		
4" PanelTRAK	4	4-1/8	1-1/2	43 (18)	0.318	1.08	0.216	0.208	-0.814	0.504	1.846	0.806	0.179	3280	1740
				54 (16)	0.398	1.35	0.425	0.259	-0.809	0.500	1.845	0.808	0.231	6421	3372
				68 (14)	0.5	1.7	0.846	0.325	-0.802	0.496	1.845	0.811	0.351	9752	5230
			33 (20)	0.279	0.95	0.111	0.348	-1.226	0.737	2.142	0.672	0.113	2066	928	
			43 (18)	0.363	1.24	0.246	0.453	-1.220	0.734	2.141	0.675	0.182	3330	1740	
			54 (16)	0.455	1.55	0.486	0.567	-1.215	0.730	2.140	0.678	0.235	6523	3372	
	2	68 (14)	0.571	1.94	0.968	0.713	-1.208	0.726	2.138	0.681	0.359	9967	5230		
		33 (20)	0.313	1.07	0.125	0.400	-0.683	0.440	2.391	0.918	0.114	2089	617		
		43 (18)	0.408	1.39	0.277	0.518	-0.678	0.437	2.392	0.920	0.184	3381	1364		
6" PanelTRAK	6	6-1/8	1-1/2	54 (16)	0.511	1.74	0.546	0.645	-0.674	0.434	2.391	0.921	0.238	6622	2709
				68 (14)	0.642	2.18	1.088	0.805	-0.668	0.430	2.390	0.922	0.366	10161	5352
				33 (20)	0.348	1.18	0.139	0.869	-1.047	0.656	2.624	0.841	0.115	2111	617
			43 (18)	0.453	1.54	0.307	1.129	-1.042	0.653	2.624	0.842	0.187	3430	1364	
			54 (16)	0.568	1.93	0.607	1.411	-1.037	0.649	2.624	0.844	0.242	6724	2709	
			68 (14)	0.714	2.43	1.209	1.768	-1.031	0.645	2.623	0.845	0.374	10375	5352	
	2	33 (20)*	0.382	1.3	0.153	0.767	-0.587	0.388	2.972	0.961	0.115	2112	462		
		43 (18)	0.498	1.7	0.338	0.992	-0.583	0.386	2.973	0.961	0.187	3431	1023		
		54 (16)	0.624	2.12	0.667	1.235	-0.579	0.383	2.972	0.962	0.242	6722	2028		
8" PanelTRAK	8	8-1/8	1-1/2	68 (14)	0.785	2.67	1.330	1.539	-0.574	0.379	2.971	0.963	0.373	10363	4077
				33 (20)*	0.417	1.42	0.166	1.674	-0.917	0.590	3.177	0.917	0.116	2134	462
				43 (18)	0.544	1.85	0.369	2.172	-0.913	0.588	3.178	0.918	0.190	3481	1023
			54 (16)	0.681	2.32	0.727	2.711	-0.908	0.585	3.177	0.918	0.246	6824	2028	
			68 (14)	0.856	2.91	1.451	3.392	-0.902	0.581	3.177	0.919	0.381	10577	4077	
			2	33 (20)*	0.382	1.3	0.153	0.767	-0.587	0.388	2.972	0.961	0.115	2112	462
	43 (18)	0.498		1.7	0.338	0.992	-0.583	0.386	2.973	0.961	0.187	3431	1023		
	54 (16)	0.624		2.12	0.667	1.235	-0.579	0.383	2.972	0.962	0.242	6722	2028		

Notes:

- 1 Section Properties Are Based on Using AISI S100-16 w/S2-20.
- 2 Axial load capacities are based on fully-braced condition (structural elements that are installed to provide full restraint or support, i.e. KL=0).
- 3 *Web depth to thickness ratio greater than 200, bearing stiffeners required in accordance with Section F5.1 of AISI S100.

I_x = Gross Moment Of Inertia about x-axis.

S_x = Gross Section Modulus about x-axis.

R_x = Gross Radius of Gyration about x-axis.

I_y = Gross Moment Of Inertia about y-axis.

S_y = Gross Section Modulus about y-axis.

R_y = Gross Radius of Gyration about y-axis.

J = St. Venant Torsion Constant.

C_w = Warping Torsion Constant.

X_o = Distance from shear center to the centroid along the principal x-axis.

m = Distance between shear center and web centerline

R_o = Polar Radius of Gyration about the centroidal principal axis.

β = 1-(X_o/r_o)²

S_{x_e} = Effective Section Modulus about x-axis.

I_{x_e} = Effective Moment Of Inertia about x-axis for deflection calculations.

Max = Allowable local buckling moment capacity about x-axis.

S_{y_c} = Effective Section Modulus about y-axis while web in compression.

I_{y_c} = Effective Moment Of Inertia about y-axis for deflection calculations while web in compression.

May_c = Allowable local buckling moment capacity about y-axis while web in compression.

S_{y_t} = Effective Section Modulus about y-axis while web in tension.

I_{y_t} = Effective Moment Of Inertia about y-axis for deflection calculations while web in tension.

May_t = Allowable local buckling moment capacity about y-axis while web in tension.

V_{ag} = Allowable Shear about x-axis.

P_a = Allowable Axial Load.