

DIVISION: 08 00 00 – OPENINGS
Section: 08 62 00 – Unit Skylights

REPORT HOLDER:
Amrize Building Envelope LLC (Elevate)
26 Century Blvd. Suite 205
Nashville, TN 37214
www.elevatecommercialbp.com

REPORT SUBJECT:
SunWave™ Skylights

1.0 SCOPE OF EVALUATION

1.1 This Research Report addresses compliance with the following Codes:

- 2021, 2018, 2015 *International Building Code*® (IBC)
- 2021, 2018, 2015 *International Residential Code*® (IRC)

NOTE: This report references the most recent Code editions cited. Section numbers in earlier editions may differ.

1.2 SunWave™ Skylights has been evaluated for the following properties:

- Structural Performance
- Durability
- Fire characteristics

1.3 SunWave™ Skylights has been evaluated for the following uses:

- SunWave™ Skylights are plastic glazed unit skylights complying with IBC Sections 2405 and 2610 and IRC Section R308.6.

2.0 STATEMENT OF COMPLIANCE

SunWave™ Skylights comply with the Codes listed in Section 1.1, for the properties stated in Section 1.2, and uses stated in Section 1.3, when installed as described in this report, including the Conditions of Use stated in Section 6.0.

3.0 DESCRIPTION

3.1 The SunWave™ Skylights are fixed unit skylights with general dimensions as shown in Table 1. This model utilizes framing members of identical cross section and identical mounting configuration. The number of fasteners required is shown in Table 1.

3.2 The single glazed SunWave™ Skylights utilize prismatic lenses of extruded acrylic or polycarbonate plastic. Glazing materials and their associated thicknesses are as outlined in Table 1. An aluminum curb frame is mounted to a wood curbing, using No. 12 x 1-1/2 inch long hex washer-head screws to form the base of the skylight assembly. Airseal foam neoprene gasket tape is utilized between the horizontal mating surfaces of the wood curb and the aluminum curb frame. The plastic glazing is mounted on top of the curb frame using GE SCS1000 Silicone or Manus-Bond 75-AM sealant. An aluminum thermal break frame is assembled over the glazing and engages the lower aluminum curb frame in a “snap-on” arrangement. No. 8 x 1/2 inch wafer modified truss head screws are installed to secure the aluminum pieces. Additional details of the skylight assemblies are shown in Figure 1. Further details of materials utilized in the assembly are as follows:

3.3 Glazing Materials: Single glazed prismatic and smooth thermoforming raw acrylic or polycarbonate material.

3.3.1 The SunWave™ Skylights utilize a glazing manufactured from Plexiglas® DR101 Acrylic (ICC-ES ESR-1653) or Sunoptics Polycarbonate (ICC-ES ESR-3362) extruded to a thickness of 0.160 inch. See Table 1.

3.4 Aluminum Components: The curb frame and the thermal break curb are manufactured from extruded 6063-T6 tempered aluminum.

3.5 Gasketing and Sealants:

3.5.1 Airseal foam neoprene gasket tape is utilized between the horizontal mating surfaces of the wood curb and the aluminum curb frame.



3.5.2 Sealing between the glazing domes and the aluminum framing is accomplished with GE SCS1000 Silicone or Manus-Bond 75-AM glazing sealant.

3.6 Fasteners: Fasteners utilized in the skylight assemblies are manufactured by PrimeSource Building Products and are recognized in ICC-ES Evaluation Report, ESR-1408. See Table 1 for descriptions and quantities.

3.6.1 The aluminum curb frame is fastened to the wood curbing utilizing zinc plated No. 12 x 1-1/2 inch self-drilling hex washer-head screws.

3.6.2 The aluminum thermal break curb is fastened to the curb frame using zinc plated No. 8 x 1/2 inch wafer modified truss head screws.

4.0 PERFORMANCE CHARACTERISTICS

4.1 For the model listed in Section 1, the maximum allowable positive and negative (wind uplift) loads are as indicated in Table 2.

4.2 The model listed in Section 1, was tested and determined to be acceptable to the uniform load, water resistance and air infiltration acceptance criteria described in Part A of ICC-ES AC16.

5.0 INSTALLATION

SunWave™ Skylights must be installed in accordance with the manufacturer's published installation instructions, the applicable Code, and this Research Report. A copy of the manufacturer's instructions must be available on the jobsite during installation.

5.1 Skylights shall be installed in accordance with IBC Sections 2405 and 2610, and IRC Section R308.6.

5.2 Skylights shall be mounted on a wood curb that raises the plastic glazing at least 4 inches above the plane of the roof.

5.3 Outside curb dimensions are indicated in Table 1. The design, attachment, flashing and placement of the wood curb to the roof deck is outside the scope of this report.

5.4 Skylights shall be attached to the curb utilizing fasteners described in this report. The fastener manufacturer, type, quantity and location are outlined in Table 1.

6.0 CONDITIONS OF USE

6.1 Installation must comply with this Research Report, the manufacturer's published installation instructions, and the applicable Code. In the event of a conflict, this report governs.

6.2 Design loads do not exceed loads indicated in Table 2 of this report.

6.3 Wood curbs must have a minimum specific gravity of 0.43 and a minimum thickness of 1-1/2 inch and sufficient height to mount the plastic glazing higher than 4 inches above the plane of the roof.

6.4 Fasteners are installed in accordance with manufacturer instructions and this report.

6.5 The status of this report is contingent on the validity of the ICC-ES reports identified herein. The revocation or expiration of any included ICC-ES reports will invalidate this report.

6.6 Where required by the Building Official, engineering calculations and details shall be provided. The calculations shall verify that the anchorage complies with the Building Code for the type of framing and condition of the supporting construction.

6.7 SunWave™ Skylights are manufactured under a quality control program with inspections by Intertek Testing Services NA, Inc.

7.0 SUPPORTING EVIDENCE

7.1 Manufacturer's drawings and installation instructions (Detail No. FS-DL-1, dated 3/23/2011).

7.2 Testing data demonstrating compliance with AAMA/WDMA/CSA 101/I.S.2/A440-17, "Standard/Specification for Windows, Doors, and Unit Skylights", American Architectural Manufacturers Association, Window and Door Manufacturers Association, and Canadian Standards Association.





7.3 Reports of testing demonstrating compliance with ICC-ES AC16, Acceptance Criteria for Plastic Glazed Skylights, approved April 2017.

7.4 Documentation of an Intertek approved quality control system for the manufacturing of products recognized in this report.

7.5 Intertek Listing Report “SunWave Skylights” on the [Intertek Directory of Building Products](#).



8.0 IDENTIFICATION

The SunWave™ Skylights are identified with the manufacturer’s name (Amrize Building Envelope LLC), address and telephone number, the product name (SunWave™ Skylights), Plastic dome classification (CC1 or CC2) and thickness of plastic glazing material prior to thermoforming, and allowable loads, Safety labeling indicating “Risk of Fall” that complies with Class 1, ANSI Standard Z35.1 specifications for accident prevention signs, the Intertek Mark as shown below, and the Code Compliance Research Report number (CCRR-0235).

9.0 OTHER CODES

This section is not applicable.

10.0 CODE COMPLIANCE RESEARCH REPORT USE

10.1 Approval of building products and/or materials can only be granted by a building official having legal authority in the specific jurisdiction where approval is sought.

10.2 Code Compliance Research Reports shall not be used in any manner that implies an endorsement of the product by Intertek.

10.3 Reference to the <https://bpdirectory.intertek.com> is recommended to ascertain the current version and status of this report.

This Code Compliance Research Report (“Report”) is for the exclusive use of Intertek’s Client and is provided pursuant to the agreement between Intertek and its Client. Intertek’s responsibility and liability are limited to the terms and conditions of the agreement. Intertek assumes no liability to any party, other than to the Client in accordance with the agreement, for any loss, expense or damage occasioned by the use of this Report. Only the Client is authorized to permit copying or distribution of this Report and then only in its entirety, and the Client shall not use the Report in a misleading manner. Client further agrees and understands that reliance upon the Report is limited to the representations made therein. The Report is not an endorsement or recommendation for use of the subject and/or product described herein. This Report is not the Intertek Listing Report covering the subject product and utilized for Intertek Certification and this Report does not represent authorization for the use of any Intertek certification marks. Any use of the Intertek name or one of its marks for the sale or advertisement of the tested material, product or service must first be approved in writing by Intertek.





TABLE 1 – SKYLIGHT MODELS AND GENERAL DESCRIPTION

Skylight Description			Glazing Description		Curb and Fastener Description			
Model Series	Size	Dome Rise (in)	Glazing Material	Glazing Thickness (in)	Nominal Outside Curb Dims.	Fastener Description (Curb Frame to Curb)	Number of Fasteners	Fastener Spacing (Measured on outside of aluminum curb frame)
SunWave™ Skylights	5ft x 8ft	16	Plexiglas® DR101 Acrylic (ESR-1653) Sunoptics Polycarbonate (ESR-3362)	0.160	63"X 123"	Zinc plated No. 12 X 1 ½ inch self-drilling hex washer head screws*	26	8" from each corner and equally spaced between for a total of 5 fasteners per 5 ft side and 8 fasteners per 8 ft side (26 fasteners total)

* Fasteners Manufactured by Primesource Building Products Ref. ICC-ES Report # ESR-1408.

TABLE 2 – SKYLIGHT MODELS AND ALLOWABLE LOADINGS

Model Series	Size	Allowable Live Load (psf)	Allowable Wind Uplift (psf)
SunWave™ Skylights	5 ft X 8 ft	30	30



PRODUCT PROFILE

Details Not To Scale

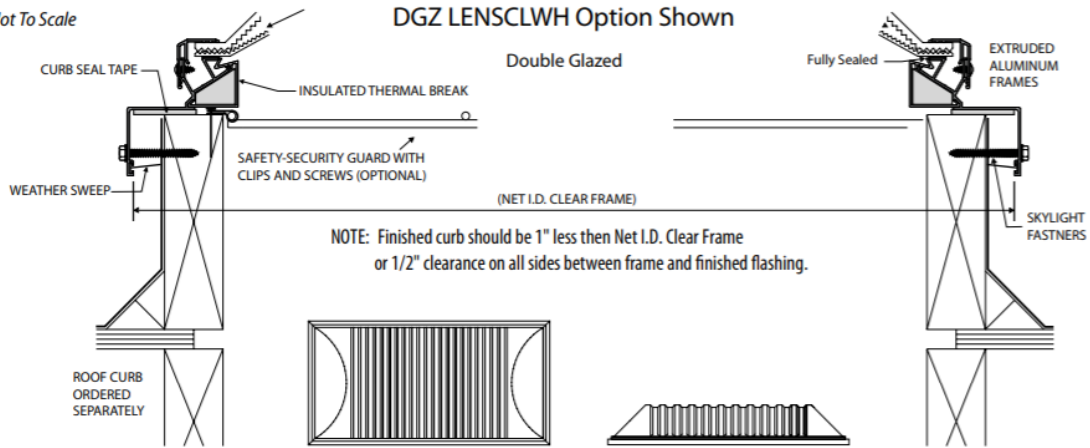

FIGURE 1 – SUNWAVE™ SKYLIGHTS