

Issue Date: 06-22-2016
Revision Date: 06-22-2026
Renewal Date: 06-30-2027

DIVISION: 05 00 00 - METALS
Section: 05 52 00 – Metal Railings

REPORT HOLDER:
Deckorators Incorporated
68956 US Highway 131
White Pigeon, MI 49099
(616)365-4201
www.Deckorators.com

REPORT SUBJECT:
ALX Classic Aluminum Railing System

1.0 SCOPE OF EVALUATION

1.1 This Research Report addresses compliance with the following Codes:

- 2015 and 2012 *International Building Code*® (IBC)
- 2015 and 2012 *International Residential Code*® (IRC)

NOTE: This report references 2015 Code sections with [2012] Code sections shown in brackets where they differ.

1.2 *ALX Classic Aluminum Railing System* has been evaluated for the following properties:

- Structural Performance

1.3 *ALX Classic Aluminum Railing System* has been evaluated for the following uses:

- Guards or guardrails under the definitions of the referenced codes. It is intended for use at or near the open sides of elevated walking areas of buildings and walkways as required by the codes.

2.0 STATEMENT OF COMPLIANCE

ALX Classic Aluminum Railing System complies with the Codes listed in Section 1.1, for the properties stated in Section 1.2 and uses stated in Section 1.3, when installed as described in this report, including the Conditions of Use stated in Section 6.

3.0 DESCRIPTION

3.1 **Level guards** are provided with rail lengths up to 96 inches in length (measured between the inside of support posts) and an installed height of up to 42 inches measured from the top of the upper rail to the walking surface. See Table 1 and Table 2 for qualified lengths and configurations.

3.2 **Stair guardrails** are provided with rail lengths up to 94 inches measured along the sloping length between the inside of supports with an installed height of up to 46 inches measured vertically from the top of the upper rail to the leading edge of the stair tread or landing. See Table 1 and Table 2 qualified lengths and configurations.

3.3 The ***ALX Classic Aluminum Railing System*** is an assemblage of an aluminum upper and lower rail, aluminum or glass vertical balusters, and 2.5-inch square aluminum posts. The system has plastic baluster to rail connectors and caps aluminum post mounts, a supporting foot piece, decorative moldings and post caps. Foot blocks are the *Classic* Baluster cut to size. The rails are secured to the posts with plastic or metal brackets. Metal brackets are diecast from Zamak 3 alloy zinc. See Figure 5.

3.4 ***ALX Classic Aluminum Railing System top rail and bottom rail*** are identical extruded 6063-T6 aluminum components of contoured cross-sectional shape. *ALX Classic* rails are available in both heavy and light thicknesses. See Table 1, Table 2 and Figure 1.

3.5 The infill area may be configured in multiple ways using 6063-T6 aluminum balusters or tempered glass balusters. See Table 1 and Table 2 for qualified assemblies and Figure 2.

3.6 **Balusters** are connected to rails with a variety of baluster connectors. See Table 1, Table 2, Table 3, and Figure 3.

3.7 ***ALX Classic posts*** are extruded 6005-T5 aluminum available in 0.080 inch (Light) and 0.15-inch wall thickness.



See Table 1 and Table 2 and Figure 4 for qualified assemblies.

3.8 The system is available in satin black, matte black, textured black, weathered brown, and white.

4.0 PERFORMANCE CHARACTERISTICS

4.1 The guardrail system described in this report has demonstrated the capacity to resist the design loadings specified in Chapter 16 of the IBC and Section R301 of the IRC when tested in accordance with ICC-ES AC273.

5.0 INSTALLATION

5.1 General: The *ALX Classic Aluminum Railing System* must be installed in accordance with the manufacturer's published installation instructions, the applicable Code, and this Research Report. A copy of the manufacturer's instructions must be available on the jobsite during installation. In the event of a conflict, this report governs.

5.2 Application:

5.2.1 Guards may be assembled in various configurations identified in Table 1 and Table 2. See Table 3 for the fastening schedule of all system components.

5.2.2 Rails may be installed at angles of 67.5° and 45° to the post face using angled adaptors. See Table 1 and Table 2 for qualified assemblies and Figure 3. Bottom rails attach to aluminum posts. See Table 1 and Table 2 for recognized configurations.

5.2.3 Structural performance of anchorage support posts to the structure shall be evaluated separately from this report.

6.0 CONDITIONS OF USE

6.1 The *ALX Classic Aluminum Railing System* described in this Research Report complies with, or is a suitable alternative to, what is specified in those Codes listed in Sections 1.0 and 2.0 of this report, subject to the following conditions:

6.1.1 Only those types of fasteners and fastening methods described in this report have been evaluated for the

installation of the *ALX Classic Aluminum Railing System*. Other methods of attachment are outside the scope of this report.

6.1.2 Anchorage of the structural post is not within the scope of this report and is subject to evaluation and approval by the building official. Anchors must satisfy the design load requirements specified in Chapter 16 of the building code and must meet the following minimum requirements:

6.1.2.1 A minimum of four anchor bolts must be used and located in the four pre-drilled holes in the structural post base plate.

6.1.2.2 The anchors must have a minimum nominal diameter equal to 3/8 inch.

6.1.2.3 When the supporting structure is a wood-framed deck, installation must include anchorage to suitable structural framing. Decking is not considered structural framing, and anchorage to decking alone is not an approved installation method.

6.1.2.4 Where required by the building official, engineering calculations and details shall be provided. The calculations shall verify that the anchorage and supporting structure complies with the building code for the type and condition of the supporting construction.

6.2.4 The glass infill panel of guardrails is considered a hazardous location as defined by section 2406.4 of the IBC. Glass must be identified by permanent etching as required by Section 2406.3 of the IBC. Each section of glass must bear the manufacturer's name or mark and the applicable test standard (Class A of ANSI Z97.1-2015 [09])

6.2.5 Guardrails using glass infill are not approved for use in wind-borne debris regions as defined by the IBC in accordance with Section 2407.1.4

6.2.6 *ALX Classic Aluminum Railing System* is manufactured under a quality control program with inspections by Intertek Testing Services NA, Inc.





7.0 SUPPORTING EVIDENCE

7.1 Drawings and installation instructions submitted by the manufacturer.

7.2 Reports of testing and engineering analysis demonstrating compliance with the performance requirements of ICC-ES Acceptance Criteria for Handrails and Guards, AC273 revised March 2016.

7.3 The reports of testing demonstrating compliance with the performance requirements of ANSI Z97.1-2015 [2009], American National Standard for Safety Glazing Materials Used in Buildings, as required by Section 2406 of the IBC and Section R308 of the IRC.

7.4 Sealed engineering calculations and drawings in accordance with provisions of the 2010 Aluminum Design Manual (ADM-2010).

7.5 Documentation of an Intertek approved quality control system for the manufacturing of products recognized in this report.

8.0 IDENTIFICATION

The *ALX Classic Aluminum Railing System* is identified with the manufacturer’s name (Deckorators Incorporated), address and phone number, the product name (ALX Classic Aluminum

Railing System), the Intertek Mark as shown below, and the Code Compliance Research Report number (CCRR-0243).



9.0 OTHER CODES

This section is not applicable.

10.0 CODE COMPLIANCE RESEARCH REPORT USE

10.1 Approval of building products and/or materials can only be granted by a building official having legal authority in the specific jurisdiction where approval is sought.

10.2 Code Compliance Research Reports shall not be used in any manner that implies an endorsement of the product by Intertek.

10.3 Reference to the <https://bpdirectory.intertek.com> is recommended to ascertain the current version and status of this report.

This Code Compliance Research Report (“Report”) is for the exclusive use of Intertek's Client and is provided pursuant to the agreement between Intertek and its Client. Intertek's responsibility and liability are limited to the terms and conditions of the agreement. Intertek assumes no liability to any party, other than to the Client in accordance with the agreement, for any loss, expense or damage occasioned by the use of this Report. Only the Client is authorized to permit copying or distribution of this Report and then only in its entirety, and the Client shall not use the Report in a misleading manner. Client further agrees and understands that reliance upon the Report is limited to the representations made therein. The Report is not an endorsement or recommendation for use of the subject and/or product described herein. This Report is not the Intertek Listing Report covering the subject product and utilized for Intertek Certification and this Report does not represent authorization for the use of any Intertek certification marks. Any use of the Intertek name or one of its marks for the sale or advertisement of the tested material, product or service must first be approved in writing by Intertek.





TABLE 1 – ALX CLASSIC RAILING SYSTEM FOR IBC RECOGNITION

ALX Classic® Aluminum Railing Systems ⁽¹⁾ Nominal Dimensions	Top / Bottom Rail Thickness	Guardrail Type	Baluster Style		Post	Code Recognition
			Baluster ⁽²⁾	Connector ⁽³⁾		
96 in x 42 in x 35°	Heavy	Stair Application	38" Classic Round	Classic Round Stair	Heavy	IBC – All Use Groups
				Classic Round Stair Gen 2		
				Swiveling Round		
			38" Estate	Estate Stair		
				Estate Stair Gen2		
				Swiveling Estate		
96 in x 42 in	Heavy	Level / Inline with 22.5° and 45° Adaptors ⁴	36" Classic Round	Classic Round Level	Heavy	
				Swiveling Round		
			36" Estate	Estate Level		
				Swiveling Estate		

¹ Actual dimensions are overall top rail length (inside of post to inside of post) and overall rail height (top of top rail to bottom of bottom rail). Rail height dimensions for the stair guardrail were measured parallel to the baluster.

² See Figure 2 for Balusters

³ See Figure 3 for Baluster Connectors

⁴ The use of 22.5° bracket adaptors in a corner condition is limited to applications where the return section the rail is installed at a 67.5° angle to the post.





TABLE 2 – ALX CLASSIC RAILING SYSTEM FOR IRC RECOGNITION

ALX Classic® Aluminum Railing Systems ⁽¹⁾ Nominal Dimensions	Top / Bottom Rail Thickness	Guardrail Type	Baluster Style		Post	Code Recognition
			Baluster ⁽²⁾	Connector ⁽³⁾		
72 in x 36 in	Light	Level / Inline Application Level / Inline with 22.5° and 45° Adaptors ⁴	30" Classic Round	Classic Round Level	Light	IRC One- and Two-Family Dwellings
				Swiveling Round		
			30" Estate	Estate Level		
				Swiveling Estate		
32" Frontier Scenic Glass	Frontier Scenic Glass					
72 in x 36 in x 35°	Light	Stair Application	32" Classic Round	Classic Round Stair Level		
				Classic Round Stair Gen 2		
				Swiveling Round		
			32" Estate	Estate Stair		
				Estate Stair Gen 2		
				Swiveling Estate		
			32" Frontier Scenic Glass	Frontier Scenic Glass		

¹ Actual dimensions are overall top rail length (inside of post to inside of post) and overall rail height (top of top rail to bottom of bottom rail). Rail height dimensions for the stair guardrail were measured parallel to the baluster.

² See Figure 2 for Balusters

³ See Figure 3 for Baluster Connectors

⁴ The use of 22.5° bracket adaptors in a corner condition is limited to applications where the return section the rail is installed at a 67.5° angle to the post.





TABLE 2 CONTINUED – ALX CLASSIC RAILING SYSTEM FOR IRC RECOGNITION

ALX Classic® Aluminum Railing Systems ⁽¹⁾ Nominal Dimensions	Top / Bottom Rail Thickness	Guardrail Type	Baluster Style		Post	Code Recognition
			Baluster ⁽²⁾	Connector ⁽³⁾		
72 in x 42 in	Light	Level / Inline Application Level / Inline with 22.5° and 45° ^o Adaptors ⁴	36" Classic Round	Classic Round Level	Heavy	IRC One- and Two-Family Dwellings
				Swiveling Round		
			36" Estate	Estate Level		
				Swiveling Estate		
72 in x 42 in x 35°	Light	Stair Application	38" Classic Round	Classic Round Stair Level		
				Classic Round Stair Gen 2		
				Swiveling Round		
			38" Estate	Estate Stair		
				Estate Stair Gen 2		
				Swiveling Estate		

¹ Actual dimensions are overall top rail length (inside of post to inside of post) and overall rail height (top of top rail to bottom of bottom rail). Rail height dimensions for the stair guardrail were measured parallel to the baluster.

² See Figure 2 for Balusters

³ See Figure 3 for Baluster Connectors

⁴ The use of 22.5° bracket adaptors in a corner condition is limited to applications where the return section the rail is installed at a 67.5° angle to the post.





TABLE 2 CONTINUED– ALX CLASSIC RAILING SYSTEM FOR IRC RECOGNITION

ALX Classic® Aluminum Railing Systems ⁽¹⁾ Nominal Dimensions	Top / Bottom Rail Thickness	Guardrail Type	Baluster Style		Post	Code Recognition
			Baluster ⁽²⁾	Connector ⁽³⁾		
96 in x 36 in	Heavy	Level / Inline Application Level / Inline with 22.5° and 45° Adaptors ⁴	30" Classic Round	Classic Round Level	Light	IRC One- and Two-Family Dwellings
				Swiveling Round		
			30" Estate	Estate Level		
				Swiveling Estate		
32" Frontier Scenic Glass	Frontier Scenic Glass					
96 in x 36 in x 35°	Heavy	Stair Application	32" Classic Round	Classic Round Stair Level		
				Classic Round Stair Gen 2		
				Swiveling Round		
			32" Estate	Estate Stair		
				Estate Stair Gen 2		
				Swiveling Estate		
			32" Frontier Scenic Glass	Frontier Scenic Glass		

¹ Actual dimensions are overall top rail length (inside of post to inside of post) and overall rail height (top of top rail to bottom of bottom rail). Rail height dimensions for the stair guardrail were measured parallel to the baluster.

² See Figure 2 for Balusters

³ See Figure 3 for Baluster Connectors

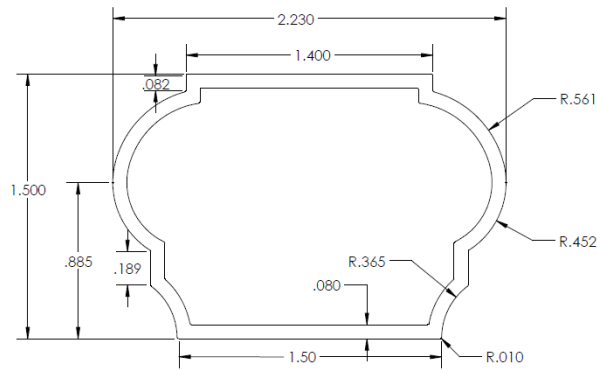
⁴ The use of 22.5° bracket adaptors in a corner condition is limited to applications where the return section the rail is installed at a 67.5° angle to the post.



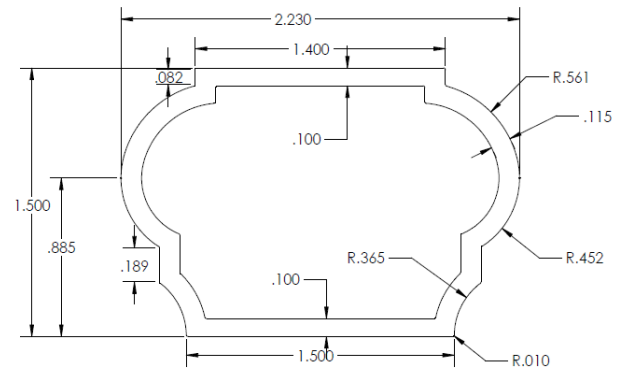


TABLE 3 – FASTENING SCHEDULE

Connection	Fastener
Top/Bottom Level Rail Bracket to Post (90°)	Three #8-18 x 3/4" (0.115 in minor diameter) square drive, trim head, self-drilling, stainless steel screws
Top Level Rail Brackets to Rail	Two #8-18 x 3/4" (0.115 in minor diameter) square drive, trim head, self-drilling, stainless steel screws
Top/Bottom Level Rail with 45 Degree and 22.5 Degree Angle Adaptors – Bracket to Post	Three #8-18 x 1-3/4" (0.107 in minor diameter) square drive, pan head, self-drilling, stainless steel screws
Bottom Level Rail Brackets to Rail	Two plastic pins
Top/Bottom Level Rail with Angle Adaptor Brackets to Post	Three #8-18 x 1-3/4" (0.115 in minor diameter) square drive, trim head, self-drilling, stainless steel screws
Top/Bottom Stair Rail Bracket to Post	Two #8-18 x 1-3/4" (0.107 in minor diameter) square drive, trim head, self-drilling, stainless steel screws
Top/Bottom Stair Rail Bracket to Rail	Two #8-18 x 3/4" (0.115 in minor diameter) square drive, trim head, self-drilling, stainless steel screws
Balusters to Adaptors	No mechanical connection - slip fit
Baluster Adaptors to Rail	One #8-15 x 1" (0.117 in minor diameter) square drive, trim head, Type A point, 304 stainless steel screws
	One #8 -1" (0.119-inch minor diameter) bugle head, square drive, self-drilling/tapping 304 stainless steel screw.
Frontier Glass Baluster	Two (per baluster end) #8 x 1.5" long screws installed through connector into rail
Foot Block to Adaptor	No mechanical connection - slip fit
Foot Block Adaptor to Rail	One #8-15 x 1" (0.117 in minor diameter) square drive, trim head, Type A point, stainless steel screws

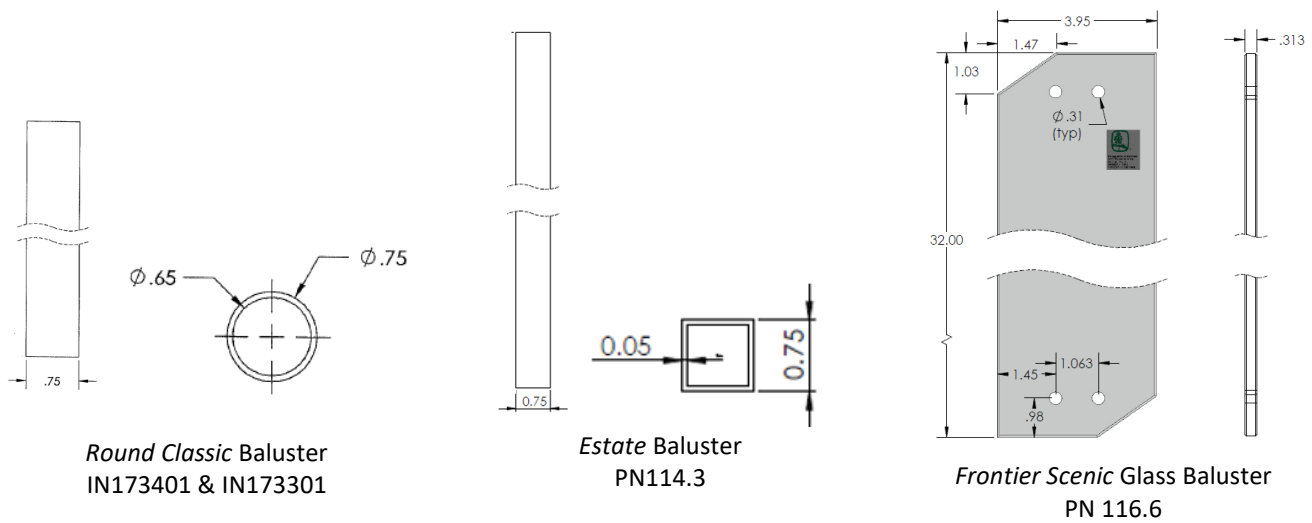


ALX Classic 72" Light Rail (Top & Bottom)
IN166401



ALX Classic 96" Heavy Rail (Top and Bottom) IN166402

FIGURE 1 – LIGHT AND HEAVY RAIL SECTIONS

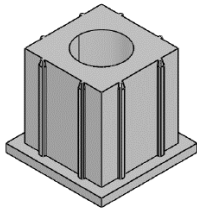


Round Classic Baluster
IN173401 & IN173301

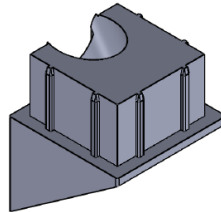
Estate Baluster
PN114.3

Frontier Scenic Glass Baluster
PN 116.6

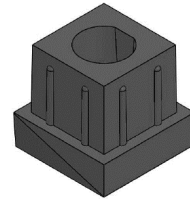
FIGURE 2 – BALUSTERS



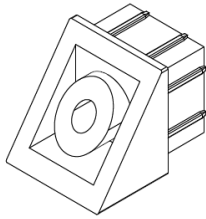
Estate Level Connector IN167701



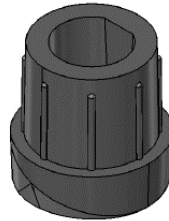
Estate Stair Connector (Gen 2) IN174601



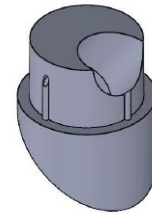
Estate (2-in-1) Stair and Level Connector IN174701



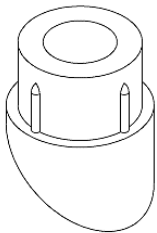
Estate Stair Connector IN167702



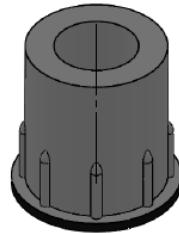
Round Classic (2-in-1) Stairs and Level Connector IN167705



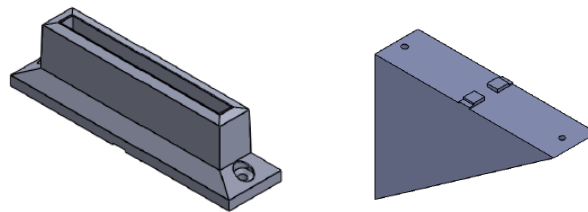
Round Classic (Gen 2) Stair Connector IN174501



Round Classic (Gen 1) Stair Connector 107.3

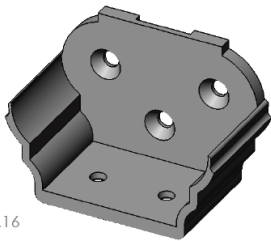


Classic Level Baluster Connector 107.2

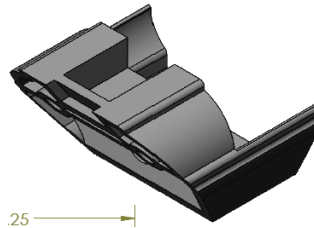


Frontier Scenic Glass Baluster Connectors - Level and Stair 125.1 and 126.1

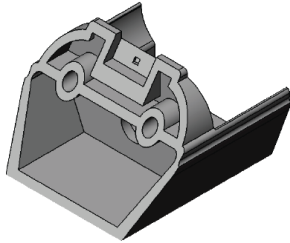
FIGURE 3 - BALUSTER TO RAIL CONNECTORS



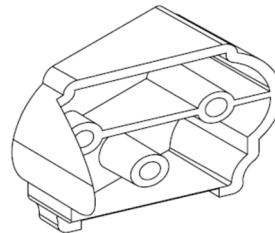
ALX Classic Level Top and Bottom Bracket IN184101



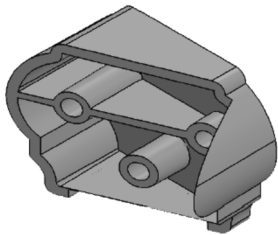
ALX Classic Upper Stair Bracket IN184301



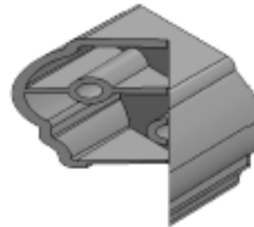
ALX Classic Lower Stair Bracket IN184501



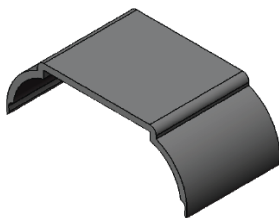
ALX Classic 22.5° / 37.5° Right Bracket Adaptor IN184701



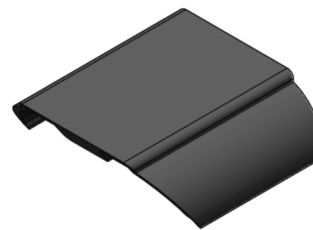
ALX Classic 22.5° / 67.5°
Left Bracket Adaptor IN184801



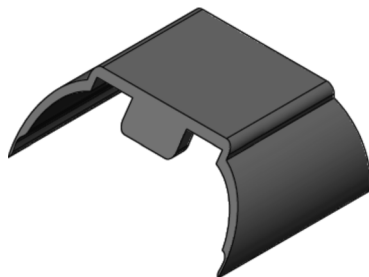
ALX Classic 45° Bracket Adaptor IN184901



ALX Classic Level Bracket Cover Plate IN184201



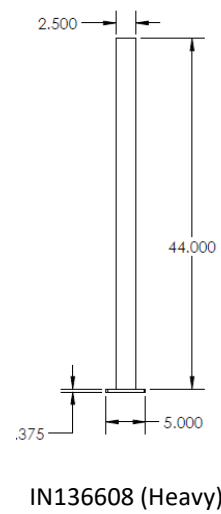
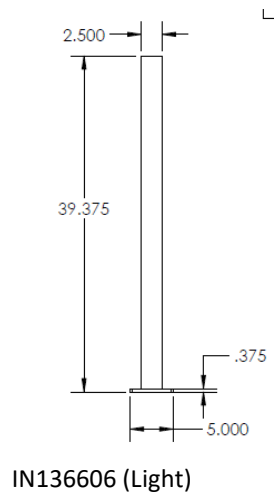
ALX Classic Stair Bracket Upper Cover Plate IN184401



ALX Classic Stair Bracket IN184601

FIGURE 4 – BRACKETS AND BRACKET COVER PLATES





Post Mounts in Varying Heights

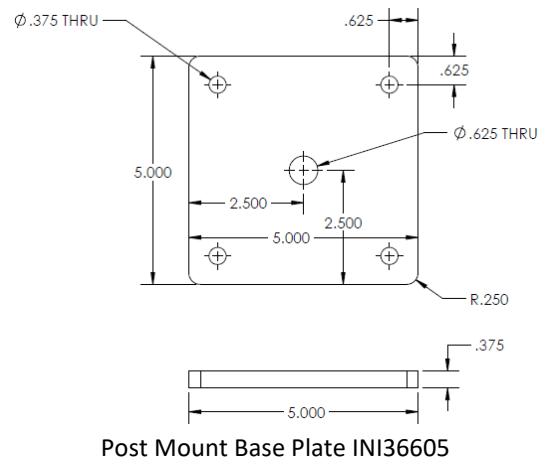
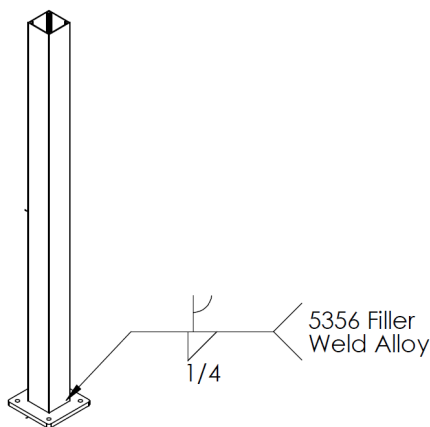
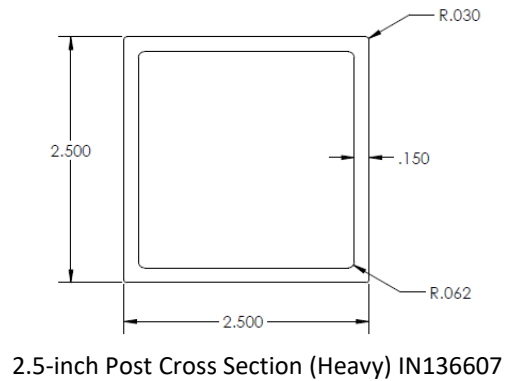
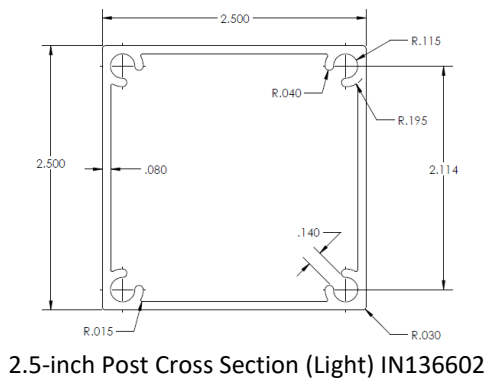


FIGURE 5 - POST MOUNT COMPONENTS



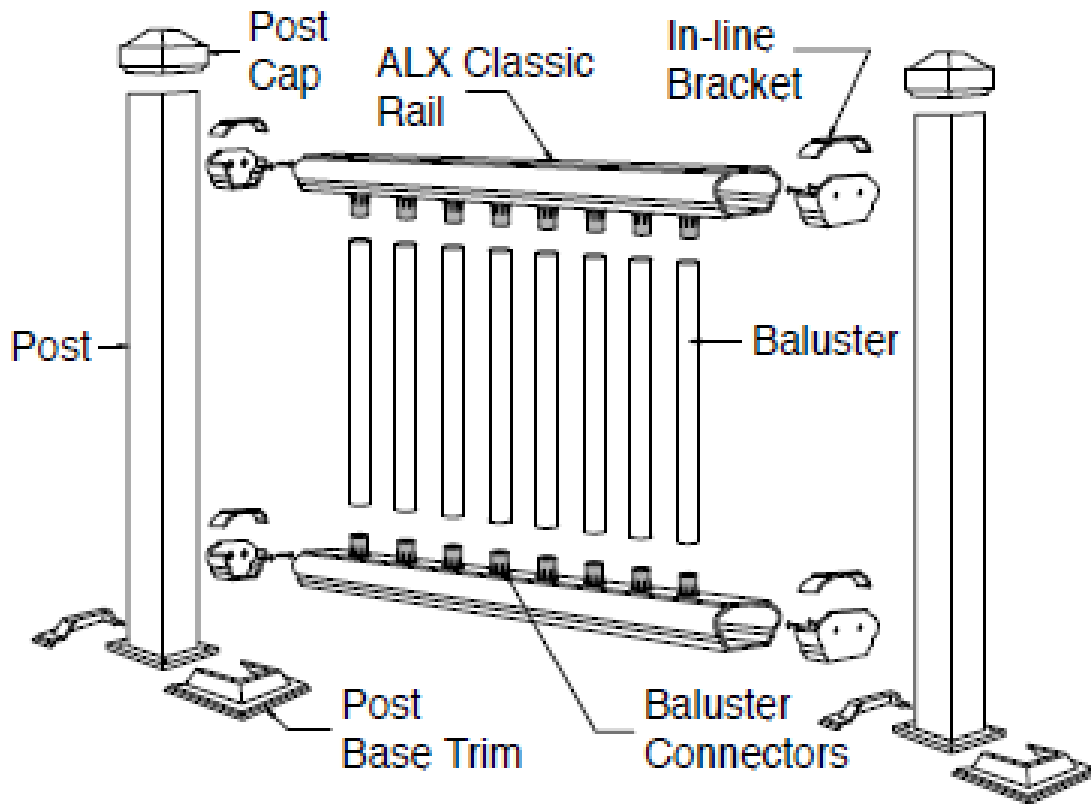
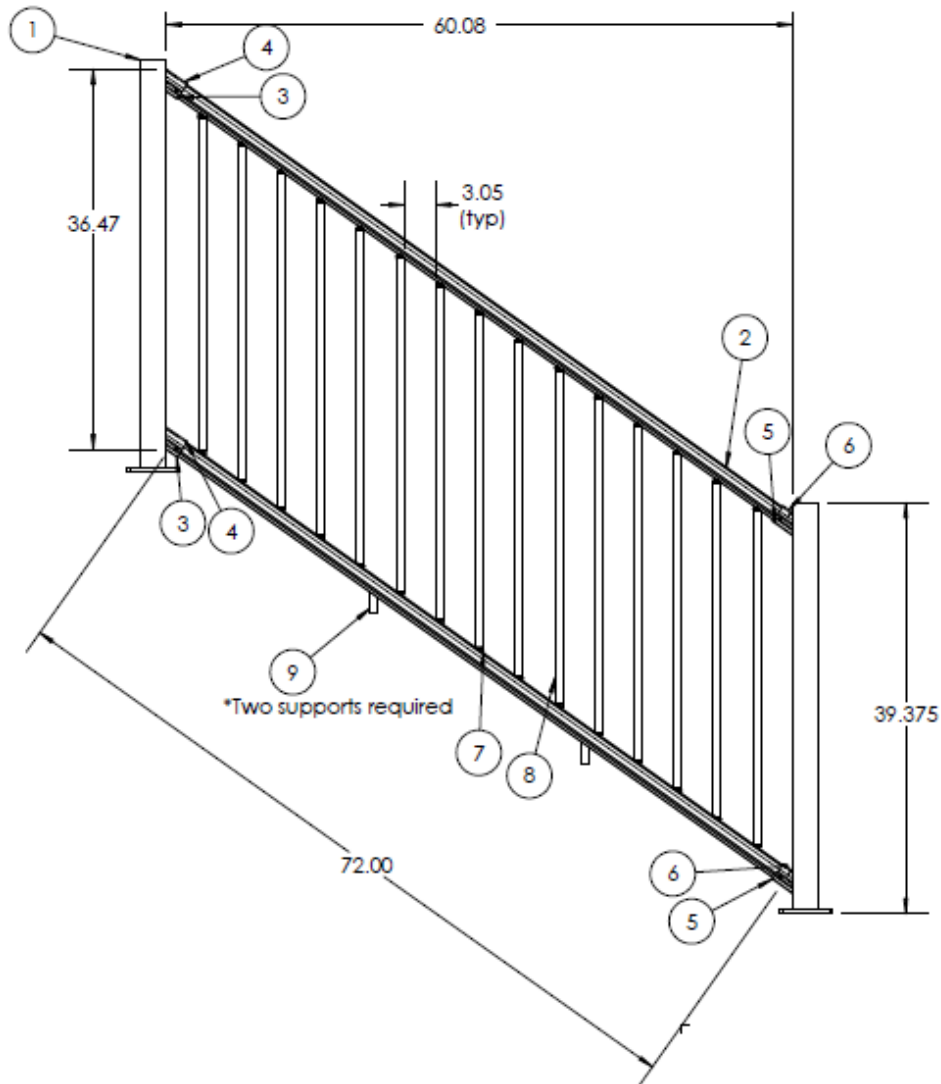


FIGURE 6 – EXPLODED VIEW OF TYPICAL INSTALLATION



ITEM NO.	PART NUMBER	QTY.
1	Post Assembly IN136606	2
2	IN166401 2672-04 6 ft Rail	2
3	IN166501 ALX Stair Bracket Upper Right	2
4	IN166601 ALX Cover Plate Upper Right	2
5	IN166502 ALX Stair Bracket Lower Left	2
6	IN166602 Cover Plate Lower Left	2
7	IN167705 2 in 1 Baluster Connector	30
8	IN173401 32 in Classic Round Baluster	15
9	IN173501 Support	2

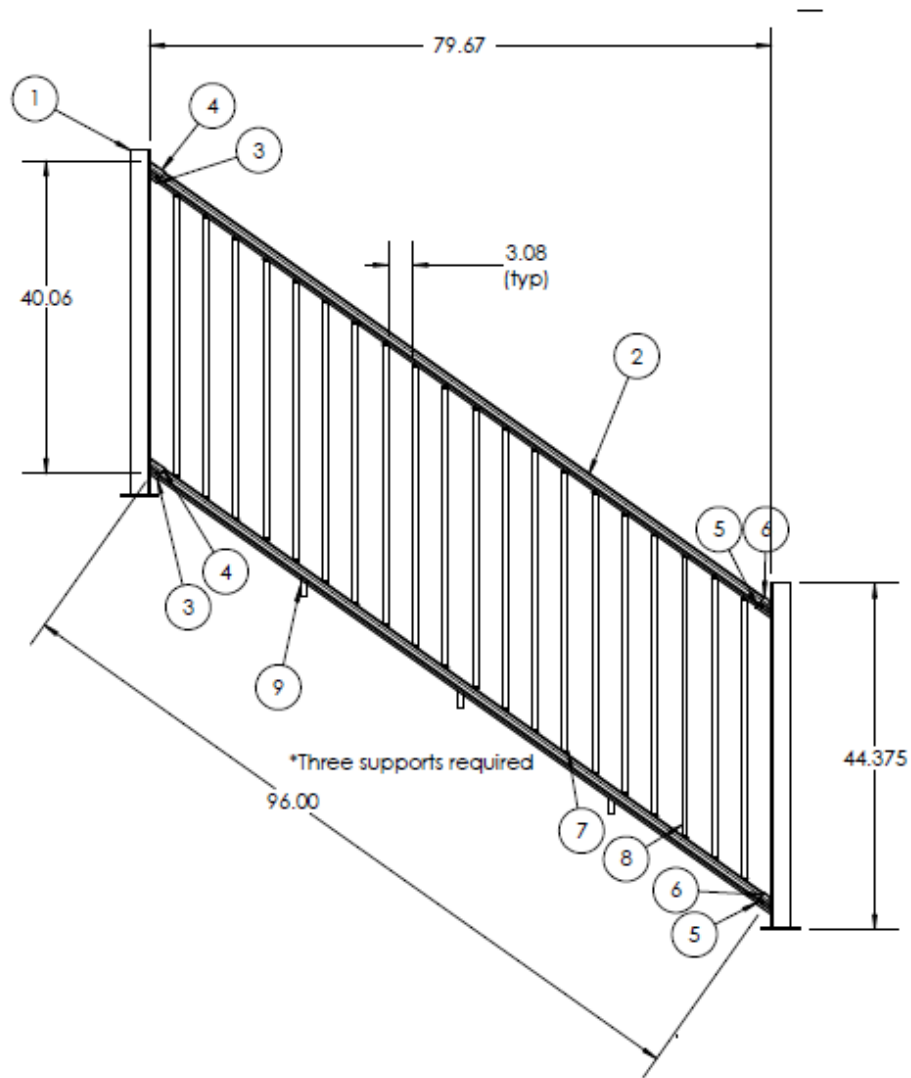
FIGURE 7 - 6 FT STAIR CLASSIC ROUND BALUSTER ASSEMBLY



545 E. Algonquin Road • Arlington Heights • Illinois • 60005
intertek.com/building

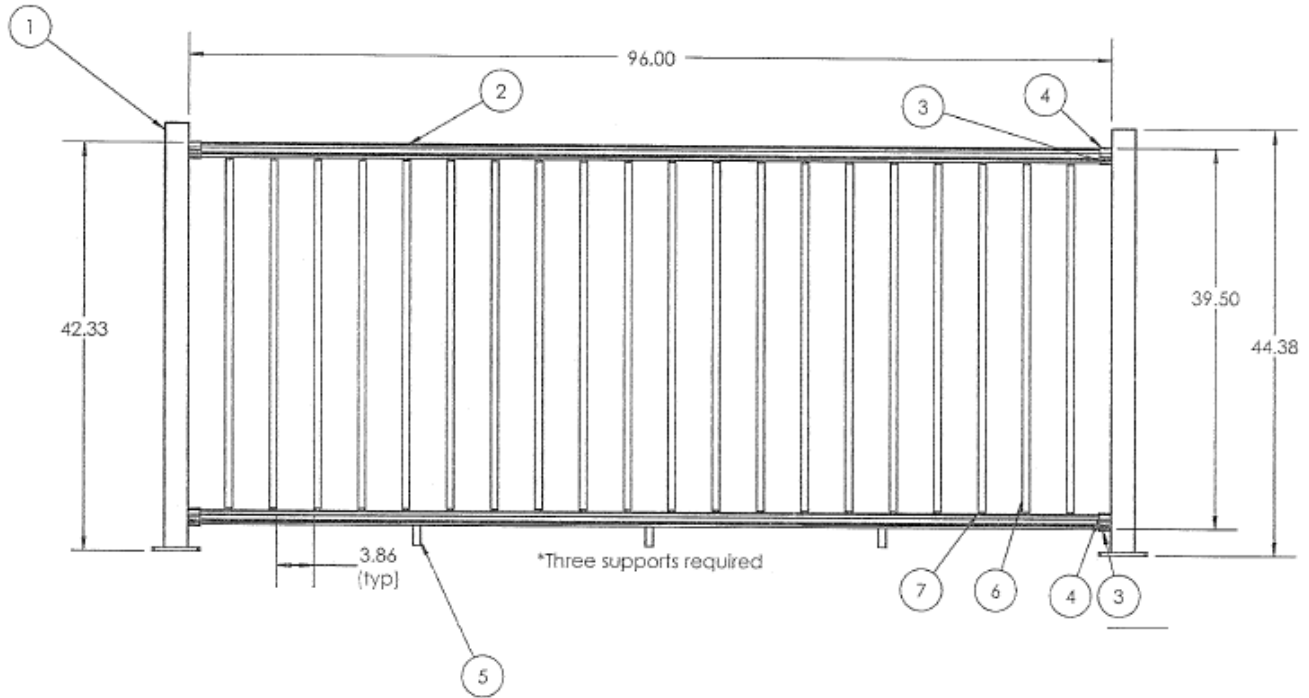


PCA-101



ITEM NO.	PART NUMBER	QTY.
1	Post Assembly IN136608	2
2	IN166402 2672-05 8 ft Rail	2
3	IN166501 ALX Stair Bracket Upper Right	2
4	IN166601 ALX Cover Plate Upper Right	2
5	IN166502 ALX Stair Bracket Lower Left	2
6	IN 166602 Cover Plate Lower Left	2
7	IN167705 2 in 1 Baluster Connector	40
8	IN173301 36 in Classic Round Baluster	20
9	IN173501 Support	3

FIGURE 8 – 8 FT STAIR CLASSIC ROUND BALUSTER ASSEMBLY



ITEM NO.	PART NUMBER	QTY.
1	Post Assembly IN136608	2
2	IN166402 2672-05 8 ft Rail	2
3	IN175001 ALX Bracket Level	4
4	IN166603 ALX Cover Plate Level Bracket	4
5	IN173501 Support	3
6	IN173301 36 in Classic Round Baluster	20
7	IN167705 2 in 1 Baluster Connector	40

FIGURE 9 – 8 FT LEVEL CLASSIC ROUND BALUSTER ASSEMBLY