

Issue Date: 09-01-2014
Revision Date: 04-13-2026
Renewal Date: 04-30-2027

DIVISION: 09 – FINISHES

Section: 09 69 00 – Access Flooring

REPORT HOLDER:

DIRTT Environmental Solutions Ltd.

7303 – 30th Street, SE

Calgary, Alberta T2C 1N6

Canada

(403) 723-5000

www.dirtt.net

tdidluck@dirtt.net

REPORT SUBJECT:

DIRTT Low Profile Raised Access Floor

1.0 SCOPE OF EVALUATION

This Research Report addresses compliance with the following Codes:

- 2024, 2021, and 2018 *International Building Code*® (IBC)
- 2025 and 2022 *California Building Code*® (CBC) (See Section 8)
- 2022 *New York City Construction Code* (See Section 8)

The DIRTT Low Profile Raised Access Floor has been evaluated for the following properties:

- Surface burning characteristics
- Structural loading
- Seismic resistance

See Table 1 for applicable Code sections related to these properties.

NOTE: This report references the most recent edition of the Codes cited. Earlier editions of the Codes may have different section numbers.

2.0 USES

The DIRTT Low Profile Raised Access Floor is a raised access floor system for use in computer rooms and general office areas. The floor system provides shallow floor space for the installation of electrical, communication, or similar systems.

The system has been evaluated as an alternative to the requirements of IBC Sections 805.1 and 718.5 and may be used in Types I and II construction. Use in fire-resistance-rated construction is outside the scope of this report.

3.0 DESCRIPTION

3.1 DIRTT Low Profile Raised Access Floor:

The DIRTT Low Profile Raised Access Floor consists of floor tiles mounted on steel support pedestals attached to, and spaced with, interconnected polypropylene webbing. The floor system has a maximum subfloor cavity height of 2 inches (51 mm). The components are illustrated in Figure 1 of this report.

3.2 Floor Tiles:

The floor tiles measure 24 inches wide by 24 inches long by 3/4 inch thick (610 mm x 610 mm x 19 mm) nominally. The tiles have a flame spread index of 0 and a smoke developed index of 5 or less when tested in accordance with ASTM E84, in accordance with Section 3.1.2 of AC151.

3.3 Floor Webs:

The floor webs are 0.1 inch thick (2.54 mm) injection-molded polypropylene. The polypropylene web material complies as Class CC1 approved plastic, as defined in IBC Section 2606, and as required in Section 3.1.1 of AC151 for use in buildings of Type I and II construction.

3.4 Steel Supporting Structures:

The minimum No. 20 gage galvanized steel supporting structures are 1-11/16 inches (43.4 mm) in height. The structure is cylindrical in shape with a base diameter of 4-1/4 inches (108 mm) and top diameter of 4 inches (101 mm). The steel structure is placed every 12 inches (304.8 mm) on center. The steel supporting structures are attached to the interconnected floor webbing and a pad



nut, composed of the same material as the webbing, on top of them. Refer to Figure 2 for illustration.

3.5 Structural Loading:

3.5.1 Uniform and Concentrated Loads: The DIRTT Low Profile Raised Access Floor complies with the uniform and concentrated loads specified in IBC Table 1607.1, Item 2, for access floor systems for office and computer use.

3.5.2 Seismic Loads: The DIRTT Low Profile Raised Access Floor has been evaluated for conformance with the seismic design requirements of Section 13.5.7 of ASCE/SEI 7 by means of third-party engineering analysis: Ficcadenti Waggoner and Castle, FWC, Report Number B14-154 for design conditions $I_p = 1.0$, $S_d = 2.1$ and $z/h \leq 0.83$. Where the required seismic design is different, seismic design loads applicable to allowable stress design (ASD) shall be determined by a licensed design professional. The pedestal adhesive and fastener system have a lateral seismic capacity of 125 lbf per pedestal with the specified fastener and adhesive which shall be used for other seismic designs.

4.0 INSTALLATION

4.1 General:

The DIRTT Low Profile Raised Access Floor system must be installed in accordance with the manufacturer's published installation instructions, the applicable Code, and this Research Report. The manufacturer's published installation instructions and this Research Report must be strictly adhered to, and a copy of the instructions must be available on the jobsite during installation.

4.2 Application:

The floor system must be installed on floors that are smooth, flat, dry, clean, free of debris, and be level within a 3/8 inch (9.5 mm) variance over a 10 foot (3048 mm) distance in any direction.

The floor web shall be positioned with the center of the corner support pedestal located directly under the corner of a floor tile or convergence of four floor tiles. Web spacers then gap adjacent floor webs to maintain 12 inch (304.8 mm) spacing between all support pedestals.

Lepage PL 400 adhesive shall be applied to the base of each pedestal.

Place two rows of floor tiles beginning with a corner over the starting point. A space of 3/32 inches (2 mm) should exist between each tile. Fasten each corner of the tile using 9/32 x 1-31/32 inch particle board screws and 1 x 1/8 inch thick washers.

Perimeter blocking must be adhered to the sub-floor with the same adhesive as used for the pedestals with the open side toward the wall, around all edges where the floor meets walls, columns and/or ramp edges. Gaps between pedestal supports and the perimeter blocking should not be greater than the span between pedestal supports (8 inches or 203 mm). The perimeter tiles are fastened to both the steel supports attached to the webbing (inside), and to the perimeter blocking (outside) after they are cut to fit.

5.0 CONDITIONS OF USE

The DIRTT Low Profile Raised Access Floor system described in this Research Report complies with, or is a suitable alternative to, what is specified in those Codes listed in Sections 1.0 and 2.0 of this report, subject to the following conditions:

5.1 Installation must comply with this Research Report, the manufacturer's published installation instructions, and the applicable Code. In the event of a conflict between the manufacturer's instructions and this report, this report governs.

5.2 All buildings in which the access floor system is installed must be fully sprinklered.

5.3 The maximum height of the subfloor space must be 2 inches (51 mm).

5.4 The area below the raised floor system must not be used for storage purposes.

5.5 Required fire-resistive walls shall extend through the access floor system to the fire-resistive floor/ceiling assembly below. Penetrations through the walls above and below the access floor system shall be protected by an approved firestop system.





5.6 Air-conveying ducts must not be located in the space created by the access floor system.

5.7 The area below the access floor system must not be used as a plenum.

5.8 The area below the access floor system must be solidly filled with noncombustible material or fireblocked in accordance with IBC Section 718.2 in such a manner that there will be no open spaces under the flooring that will exceed 3000 square feet (279 m²) in area, and such open spaces must not extend under or through permanent partitions or walls in accordance with IBC Section 805.1.1.

5.9 Electrical wiring methods permitted below the access floor system shall be in compliance with Section 645-5(E) of the NFPA 70, National Electrical Code.

5.10 The access floor system must be supported directly on a masonry or concrete floor of fire-resistive construction.

5.11 Seismic design and calculations shall be supplied to the building official for approval for each project based on parameters as described in Section 3.5.2 of this report.

5.12 Periodic special inspection is required for anchorage of access floors in structures assigned Seismic Design Category D, E or F in accordance with IBC Section 1705.13.5.1.

5.13 The raised floor system is not evaluated for equipment anchored to the access floor panels or pedestals which are seismic load conditions outside the scope of this report.

5.14 The components of the access floor system are manufactured by Ningbo OSYI Industrial Co., Ltd. and Guangzhou MeiBao Board Co., Ltd. These facilities are under a quality control program with inspection by Intertek Testing Services NA, Inc.

6.0 SUPPORTING EVIDENCE

6.1 Reports of tests in accordance with ASTM E84, ASTM D635, ASTM D1929, ASTM D2843, and ASTM E2322.

6.2 Ficcidenti Waggoner and Castle, FWC, Report Number B14-154, dated August 29, 2014.

6.3 Data in accordance with the ICC-ES Acceptance Criteria for Fixed-Height, Low-Profile, Raised-Floor System (AC151), dated February 2007.

6.4 Intertek Listing Report "[DIRTT Low Profile Raised Access Floor](#)".

6.5 CISCA Recommended Test Procedures for Access Floors (2008), Section 6: Pedestal Overturning Moment Test by Intertek dated 8/29/14.

6.6 CISCA Recommended Test Procedures for Access Floors (1987), Section 5: Pedestal Axial Load Test by Intertek dated 06/24/05.

6.7 Supplementary Intertek Test Report (Pedestal Fastener Shear Test).

7.0 IDENTIFICATION

The components of the DIRTT Low Profile Raised Access Floor system described in this Research Report are identified by markings bearing the report holder's name, the Intertek Mark, and the Research Report number (CCRR-1023). The lot number is also identified on packaging of the Floor Tile and Supporting components.

8.0 OTHER CODES

8.1 California Building Code:

The DIRTT Low Profile Raised Access Floor system described in Sections 2.0 through 7.0 of this report complies with the 2025 and 2022 *California Building Code*, subject to the Conditions of Use stated in Sections 5.1 through 5.14.

8.2 New York City Construction Code:

The DIRTT Low Profile Raised Access Floor system was evaluated for compliance with the New York City Office of Technical Certification and Research (OTCR) Bulletin #2015-009, issued May 8, 2015.





The DIRTT Low Profile Raised Access Floor system described in Sections 2.0 through 7.0 of this report complies with Bulletin #2015-009, subject to the Conditions of Use stated in Section 5 of this report, and the restrictions and conditions of acceptance outlined in Bulletin #2015-009.

9.0 CODE COMPLIANCE RESEARCH REPORT USE

9.1 Approval of building products and/or materials can only be granted by a building official having legal authority in the specific jurisdiction where approval is sought.

9.2 Code Compliance Research Reports shall not be used in any manner that implies an endorsement of the product by Intertek.

9.3 Reference to the <https://bpdirectory.intertek.com> is recommended to ascertain the current version and status of this report.

This Code Compliance Research Report ("Report") is for the exclusive use of Intertek's Client and is provided pursuant to the agreement between Intertek and its Client. Intertek's responsibility and liability are limited to the terms and conditions of the agreement. Intertek assumes no liability to any party, other than to the Client in accordance with the agreement, for any loss, expense or damage occasioned by the use of this Report. Only the Client is authorized to permit copying or distribution of this Report and then only in its entirety, and the Client shall not use the Report in a misleading manner. Client further agrees and understands that reliance upon the Report is limited to the representations made therein. The Report is not an endorsement or recommendation for use of the subject and/or product described herein. This Report is not the Intertek Listing Report covering the subject product and utilized for Intertek Certification and this Report does not represent authorization for the use of any Intertek certification marks. Any use of the Intertek name or one of its marks for the sale or advertisement of the tested material, product or service must first be approved in writing by Intertek.



545 E. Algonquin Road • Arlington Heights • Illinois • 60005
[intertek.com/building](https://www.intertek.com/building)



TABLE 1 – PROPERTIES EVALUATED

PROPERTY	IBC SECTION	CBC SECTION
Surface Burning Characteristics	804	804
Structural Loading	Table 1607.1	1607.1
Seismic Resistance	1613 (Section 13.5.7 of ASCE 7)	1613 (Section 13.5.7 of ASCE 7)
Use in Types I and II Construction	805.1.1 and 718.5	805.1.1 and 718.5

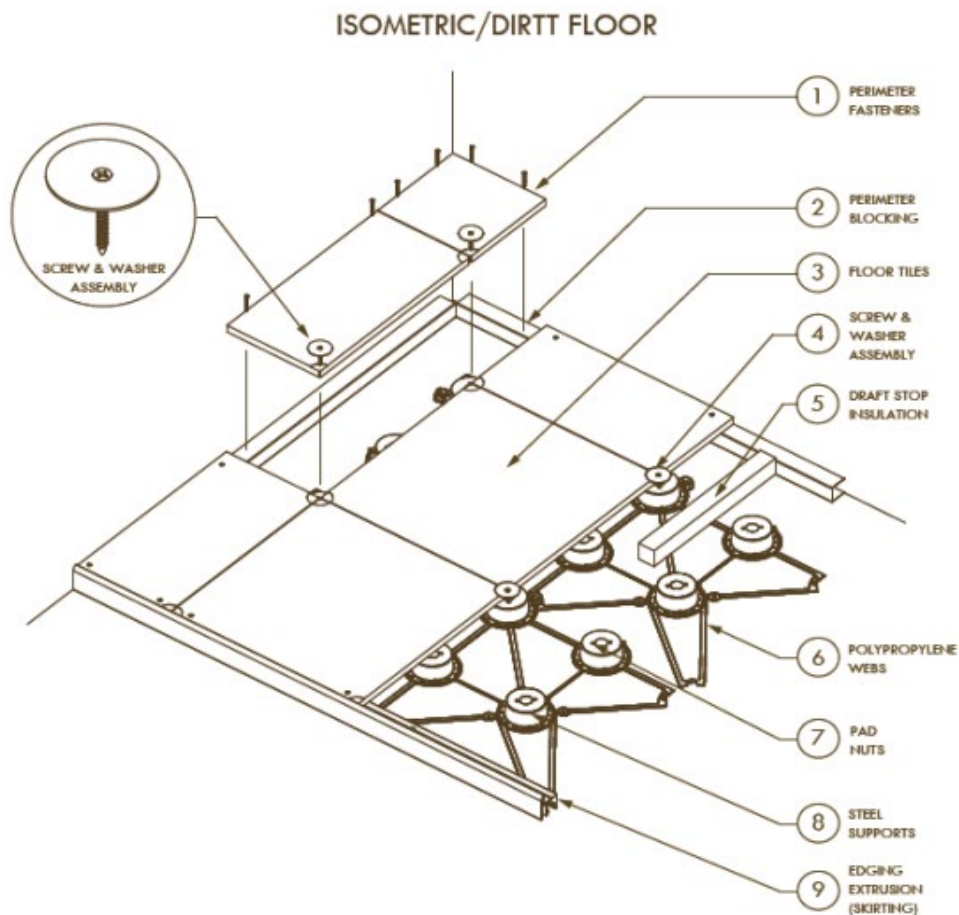

FIGURE 1a – FLOOR SYSTEM (Web Design Version #1)

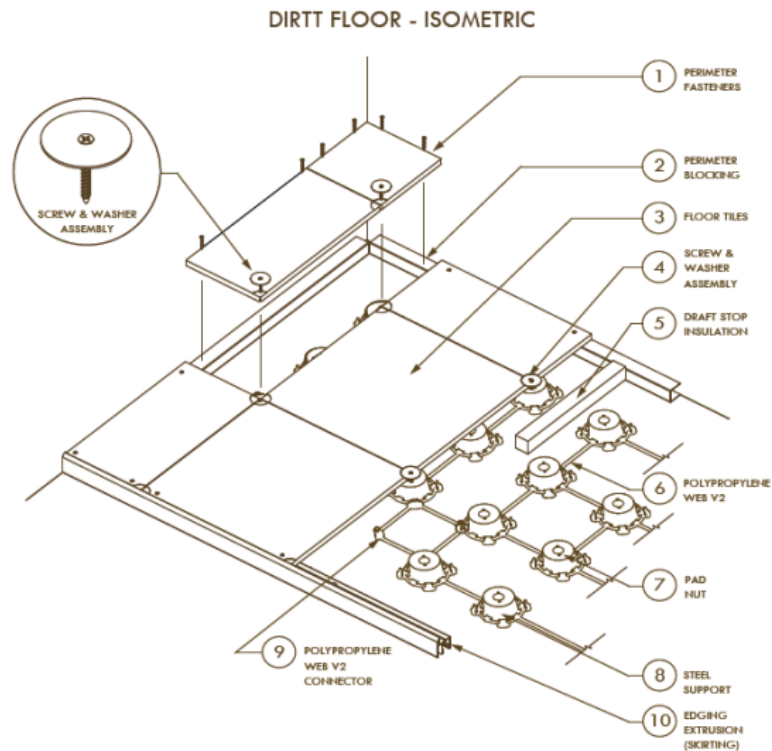

FIGURE 1b – FLOOR SYSTEM (Web Design Version #2)

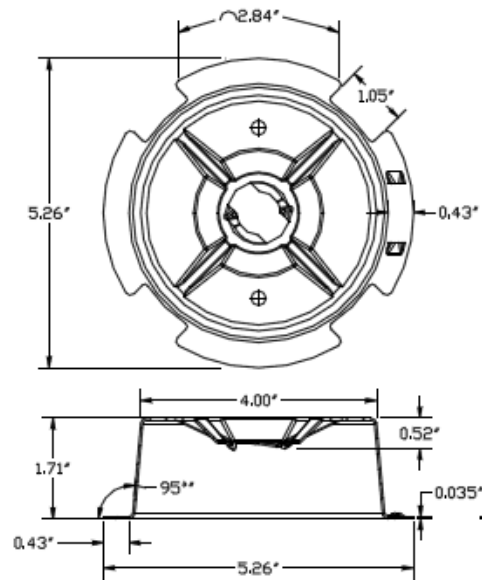

FIGURE 2 – SUPPORTING STEEL STRUCTURE