

Issue Date: 09-28-2017
Revision Date: 10-29-2024
Renewal Due: 10-31-2025

DIVISION: 06 00 00 – WOOD, PLASTICS, AND COMPOSITES
Section: 06 50 00 – Structural Plastics
Section: 06 53 00 – Plastic Decking

REPORT HOLDER:

Eva-Last Americas, LLC
6600 Chase Oaks Blvd.
Suite 150
Plano, TX 75023 www.eva-last.com

REPORT SUBJECT:

Groove Deck Boards (DSG02)
Non-Groove Deck Boards (DSN02)
Stair Tread Boards (SST01)

1.0 SCOPE OF EVALUATION

1.1 This Research Report addresses compliance with the following Codes:

- 2024, 2021, 2018 *International Building Code*® (IBC)
- 2024, 2021, 2018 *International Residential Code*® (IRC)

NOTE: This report references 2024 Code sections with [2021, 2018] Code sections shown in brackets where they differ.

1.2 The Deck Boards have been evaluated for the following properties (see Table 1):

- Structural Performance
- Durability
- Surface Burning
- Decay Resistance
- Termite Resistance

1.3 The Deck Boards have been evaluated for the following uses (see Table 1):

- General – The deck boards are intended for use as a walkway surface on exterior decks, balconies, porches, and walkways, including stairs as further defined herein. The Stair Tread Board is intended for stair applications.

- Deck boards identified in this report may be used in one- and two-family dwellings regulated by the IRC and other construction types regulated by the IBC in accordance with IBC Section 705.2.3. [1406.3] *Combustible Projections* where the fire-resistant rated floor construction is not required for the deck or balcony.

2.0 STATEMENT OF COMPLIANCE

The deck and stair boards comply with the Codes listed in Section 1.1, for the properties stated in Section 1.2 and uses stated in Section 1.3, when installed as described in this report, including the Conditions of Use stated in Section 6.0.

3.0 DESCRIPTION

3.1 General: The deck board is a co-extruded wood fiber composite core with a cap-stock on all surfaces. The deck boards are produced in the following colors: Tiger Cove, Spanish Saffron, Kona Sunset, Cape Town Grey, Espresso Roast, Sapphire Silver, and Sahara Sand.

3.2 The deck boards are available with square, stair, and grooved cross-sections. Stair board applications are a square cross-section. The deck boards have a rectangular cross-section with nominal dimensions of 5.51 in. (140 mm) wide by 0.91 in. (23 mm) thick. The Groove Deck Boards are also available with grooves, 0.2 in. (5 mm) deep by 0.4 in. (10 mm) wide, to accept hidden fasteners, the overall dimensions are 5.51 in. x 0.9 in. (140 mm x 23 mm) The Stair Tread Boards (square) are 12.8 in. (325 mm) wide x 1.18 in. (30 mm) thick. See Figures 1 through 3. All deck boards are embossed with a plowed finish.

4.0 PERFORMANCE CHARACTERISTICS

4.1 The deck and stair boards are rated for a uniform live load of 100 lbs/ft² (4.79 kN/m²) when installed on support framing spaced at 16 in. (406 mm).

4.2 The stair boards are rated for the Code-prescribed concentrated load equal to 300 lb. (1335 N) when installed with a maximum 16 in. (406 mm) support span.



4.3 The deck and stair boards are rated for wind uplift resistance with the fastening systems as described in Table 1.

4.4 The deck boards have a flame spread index of less than 200 when tested according to ASTM E84. The referenced criteria, AC174, requires a flame spread index not exceeding 200.

4.5 Materials are deemed equivalent to preservative treated or naturally durable wood for resistance to weather effects, attack from termites, and fungus decay.

4.6 Structural performance has been demonstrated for a temperature range from -20°F to 125°F (-29°C to 52°C).

4.7 Stair treads shall be installed in a minimum two-span condition.

5.0 INSTALLATION

5.1 General:

The Deck Boards must be installed in accordance with the manufacturer's published installation instructions, the applicable Code, and this Research Report. A copy of the manufacturer's instructions must be available on the jobsite during installation.

5.2 Application:

5.2.1 The square, stair, and grooved deck boards are fastened with the fastening system as described in Table 1. See Figure 4 for fastening.

5.2.2 Face-fastening of the square deck boards shall be fastened with two 2-1/2 in. (63.5 mm) top fixing CDS screws at each joist, 1-3/16 in. (30 mm) from any edge of the deck board. The grooved deck boards shall not be face-fastened. Grooved deck boards are fastened with one hidden fastener at each joist, 25/32 in. (20 mm) from the end of the deck board.

6.0 CONDITIONS OF USE

6.1 Installation must comply with this Research Report, the manufacturer's published installation instructions, and the applicable Code. In the event of a conflict, this report governs.

6.2 The deck and stair boards are intended for use as a walkway surface on exterior decks, balconies, porches, and walkways, including stairs as further defined herein.

6.3 Deck boards placed at an angle other than 90 degrees to the supporting joist will require support framing at a reduced spacing such that the span of the deck board does not exceed 16 in. (406 mm).

6.4 The wind uplift resistance rating recognized in this report is based on attachment to treated Southern Pine framing (specific gravity, $G=0.60$). Installation on wood framing with a lesser specific gravity may result in a lower wind uplift rating.

6.5 Where required by the building official, engineering calculations and details shall be provided. The calculations shall verify that the anchorage complies with the Building Code for the type of framing and condition of the supporting construction.

6.6 Compatibility of the supporting construction materials with all metal fasteners are subject to approval by the Code official.

6.7 All products are manufactured in accordance with the manufacturer's approved quality control system with inspections by Intertek.

7.0 SUPPORTING EVIDENCE

7.1 Manufacturer's drawings and installation instructions.

7.2 Reports of testing in accordance with ICC-ES AC174, *Acceptance Criteria for Deck Board Span Ratings and Guardrail Systems (Guards and Handrails)*, revised December 2019.

7.3 The reports of testing and engineering analysis demonstrating compliance with the performance requirements of ASTM D7032-21 [17, 14], *Standard Specification for Establishing Performance Ratings for Wood-Plastic Composite Deck Boards and Guardrails Systems (Guards or Handrails)*.

7.4 Documentation of an Intertek approved quality control system for the manufacturing of products recognized in this report.



Intertek





8.0 IDENTIFICATION

The Groove Deck Boards, Non-Groove Deck Boards and Stair Tread Boards are identified with the manufacturer’s name (Eva-Last Hong Kong Limited), address and telephone number, the product name (Groove Deck Boards, Non-Groove Deck Boards and Stair Tread Boards), the statement “Complies with ASTM D 7032.”, the Intertek Mark as shown below, and the Code Compliance Research Report number (CCRR-1096).



9.0 OTHER CODES

This section is not applicable.

10.0 CODE COMPLIANCE RESEARCH REPORT USE

10.1 Approval of building products and/or materials can only be granted by a building official having legal authority in the specific jurisdiction where approval is sought.

10.2 Code Compliance Research Reports shall not be used in any manner that implies an endorsement of the product by Intertek.

10.3 Reference to the bpdirectory.intertek.com is recommended to ascertain the current version and status of this report.

This Code Compliance Research Report (“Report”) is for the exclusive use of Intertek’s Client and is provided pursuant to the agreement between Intertek and its Client. Intertek’s responsibility and liability are limited to the terms and conditions of the agreement. Intertek assumes no liability to any party, other than to the Client in accordance with the agreement, for any loss, expense or damage occasioned by the use of this Report. Only the Client is authorized to permit copying or distribution of this Report and then only in its entirety, and the Client shall not use the Report in a misleading manner. Client further agrees and understands that reliance upon the Report is limited to the representations made therein. The Report is not an endorsement or recommendation for use of the subject and/or product described herein. This Report is not the Intertek Listing Report covering the subject product and utilized for Intertek Certification and this Report does not represent authorization for the use of any Intertek certification marks. Any use of the Intertek name or one of its marks for the sale or advertisement of the tested material, product or service must first be approved in writing by Intertek.





TABLE 1 – PROPERTIES EVALUATED

Board Type	Span/Load Ratings ⁽¹⁾	Fastening	Wind Uplift Resistance ⁽²⁾
Non-Grooved Deck Board (Model: DSN02)	16 in./100 psf 406 mm/ (4.79 kN/m ²)	Face Fastened with two top fixing CDS Screws 2-½” per joist Edge of deck fastening: along the length of the deck board at 16” on center, one top fixing CDS screw 2-½”	150 psf (7.2 kN/m ²)
Groove Deck Board (Model: DSG02)	16 in./100 406 mm/ (4.79 kN/m ²)	<u>Hidden Fastener System:</u> Halo Clip fastened with one 1-½” Hulk Torpedo Clip Screw Edge of deck fastening: along the length of the deck board at 16” on center, one top fixing CDS screw 2-½”	150 psf (7.2 kN/m ²)
Stair Tread Board (Model: SST01)	16 in. (406 mm) maximum span	Face Fastened with two top fixing CDS Screws 2-½” per joist	150 psf (7.2 kN/m ²)

- (1) Span/Load rating is the maximum span in inches and the maximum allowable load in pounds per square feet (psf). The maximum allowable loads indicated include applicable end use factors. No additional adjustments should be taken.
- (2) Wind uplift resistance is based on installation described in Section 5. Values have been adjusted for end use. No further adjustment shall be made.
- (3) 1 inch=25.4 mm, 100 psf= 4.79 kN/m²

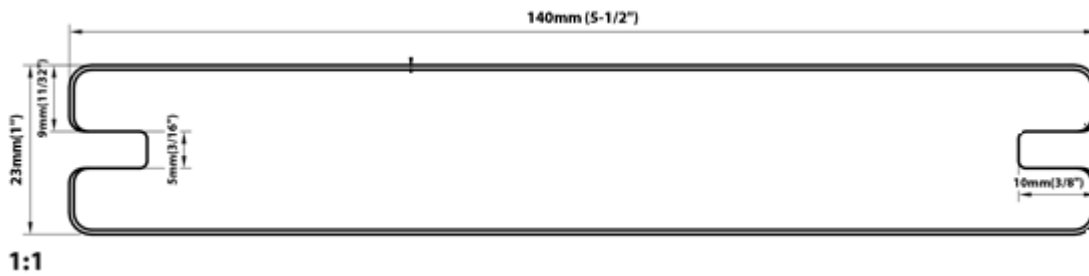

FIGURE 1 – GROOVE DECK BOARD (DSG02)

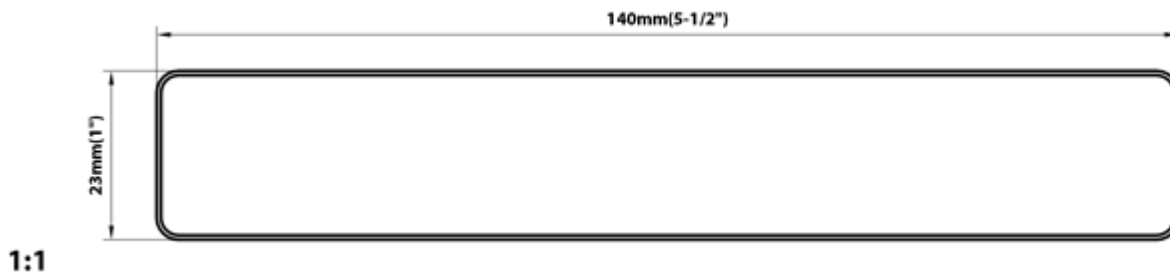

FIGURE 2 – NON-GROOVE DECK BOARD (DSN02)

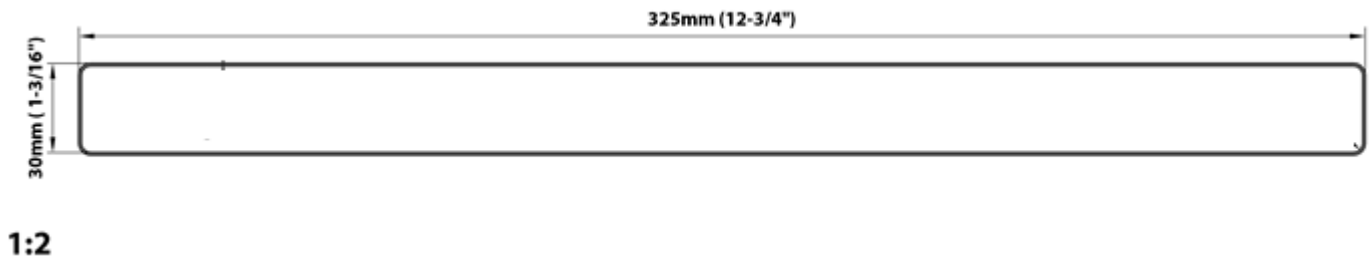
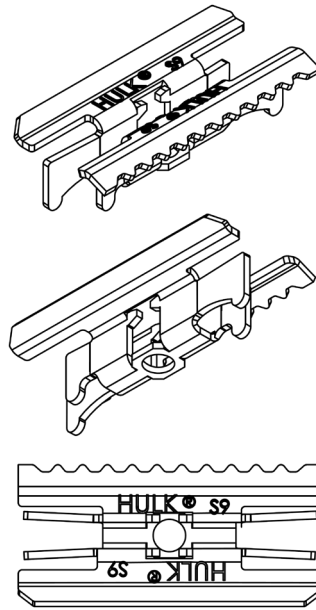
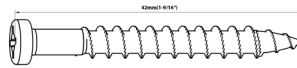

FIGURE 3 – STAIR TREAD BOARD (SST01)



Halo Clip



Hulk Torpedo Screw

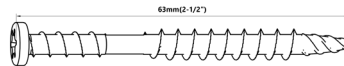

Composite Deck Screw

FIGURE 4 – HIDDEN FASTENER SYSTEM